

ARYAN SCHOOL OF ENGINEERING & TECHNOLOGY

BARAKUDA, PANCHAGAON, BHUBANESWAR, KHORDHA-752050



LECTURE NOTE

SUBJECT NAME- HYDRAULIC MACHINES & INDUSTRIAL FLUID POWER

BRANCH – MECHANICAL ENGINEERING

SEMESTER – 5TH SEM

ACADEMIC SESSION - 2022-23

PREPARED BY – BIJANANANDA MISHRA

Hydraulic Machines - Turbines

Hydraulic Machines: Hydraulic machines are defined as those machine which convert hydraulic energy into mechanical energy.

Turbines: The hydraulic machine which convert the hydraulic energy into mechanical energy are called turbines.

- This mechanical energy is used in running an electric generator which is directly coupled to the shaft of the turbine.
- Hence the mechanical energy is converted into electrical energy.
- The electric power obtained from the hydraulic energy is known as Hydro-electric power.

Definitions of Heads and efficiencies of a Turbine

1. Gross Head: The distance between the head race level and tail race level when no water is flowing is known as Gross Head. It is denoted by " H_g ".

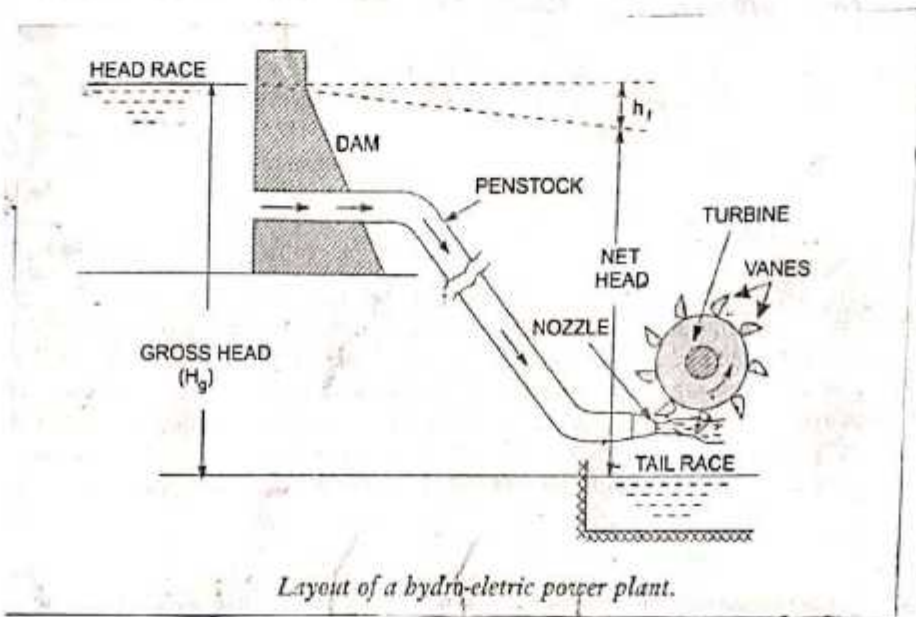
2. Net Head: It is also called effective head and is defined as the head available at the inlet of the turbine. When water is flowing from head race to the turbine, a loss of head due to friction between the ^{water} and the penstock occurs. If h_f is head loss due to friction between penstock and water then

$$\text{Net head } (H) = H_g - h_f$$

Where $H_g =$ Gross head

$$h_f = \frac{4 \times f \times L \times V^2}{D \times 2g}$$

in which $V =$ Velocity of flow in penstock.
 $L =$ Length of penstock.
 $D =$ Diameter of Penstock.



Classification of Hydraulic Turbines:

1. According to the type of energy at inlet
 - (a) Impulse turbine
 - (b) Reaction turbine.
2. According to the direction of flow through runner:
 - (a) Tangential flow turbine
 - (b) Radial flow turbine
 - (c) Axial flow turbine
 - (d) Mixed flow turbine
3. According to the head at inlet of turbine.
 - (a) High head turbine
 - (b) Medium head turbine
 - (c) Low head turbine
4. According to the specific speed of the turbine:
 - (a) Low specific speed turbine
 - (b) Medium specific speed turbine
 - (c) High specific speed turbine

Impulse Turbine: If at the inlet of the turbine, the energy available is only kinetic energy, the turbine is known as impulse turbine.

Reaction Turbine: If at the inlet of the turbine, the water possesses kinetic energy as well as pressure energy the turbine is known as reaction turbine.

Tangential flow turbine: If the water flows along the tangent of the runner, the turbine is known as tangential flow turbine.

Radial flow turbine: If the water flows in the radial direction through the runner, the turbine is called radial flow turbine.

Inward flow radial turbine: If the water flows from outward to inward radially, the turbine is known as inward radial flow turbine.

Outward radial flow turbine: If water flows radially from inwards to outwards, the turbine is known as outward radial flow turbine.

Axial flow turbine: If the water flow through the runner along the direction parallel to the axis of rotation of the runner, the turbine is called axial flow turbine.

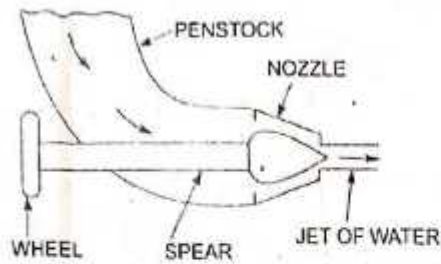
Mixed flow turbine: If the water flows through the runner in the radial direction but leaves in the direction parallel to axis of rotation of the runner, the turbine is called mixed flow turbine.

Pelton Wheel :

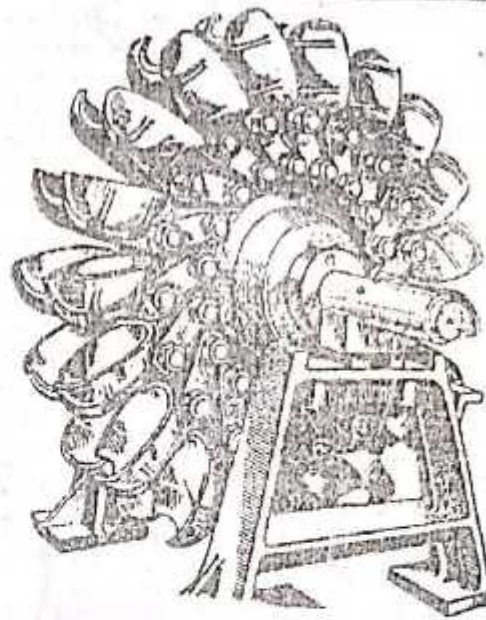
- Pelton Wheel is a tangential flow impulse Turbine as the water strikes the bucket along the tangent of the runner.
- The energy available at the inlet of the turbine is only kinetic energy.
- It is named as pelton turbine after an American Engineer L. A Pelton.
- This turbine is used for high heads.
- The main parts of the Pelton turbine are as follows:

1. Nozzle and flow Regulating Arrangement: The amount of water striking the buckets (vanes) of the runner is controlled by providing a spear in the nozzle as shown in fig given below. The spear is a conical needle which is operated either by hands or automatically. When the spear is pushed forward into the nozzle the amount of water striking the runner is reduced and vice-versa.

2. Runner with Buckets: It consist of circular disc on the periphery of which a number of buckets evenly spaced are fixed. The shape of the bucket is of a double hemispherical cup which is divided into two symmetrical parts by a dividing wall which is known as splitter. The buckets are shaped in such a way that the jet gets deflected through 160° or 170° . The buckets are generally made of cast iron, cast steel bronze or stainless steel depending upon the head at inlet of the turbine.

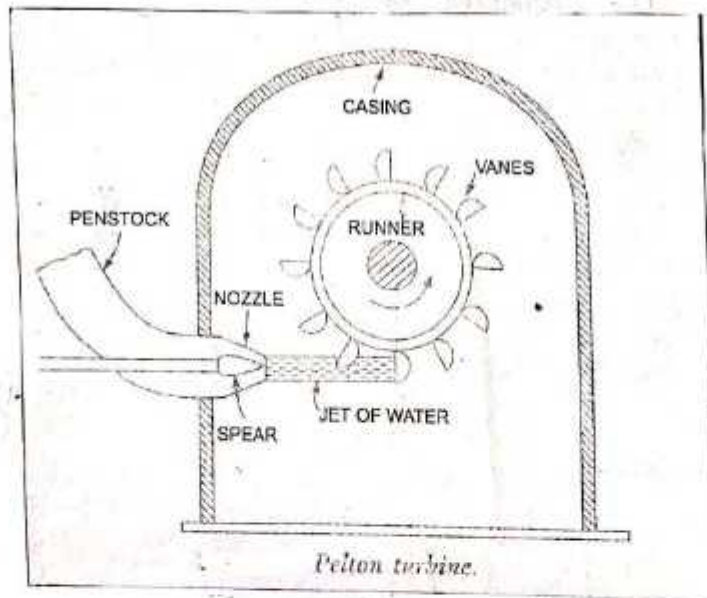


Nozzle with a spear to regulate flow.



Runner of a pelton wheel.

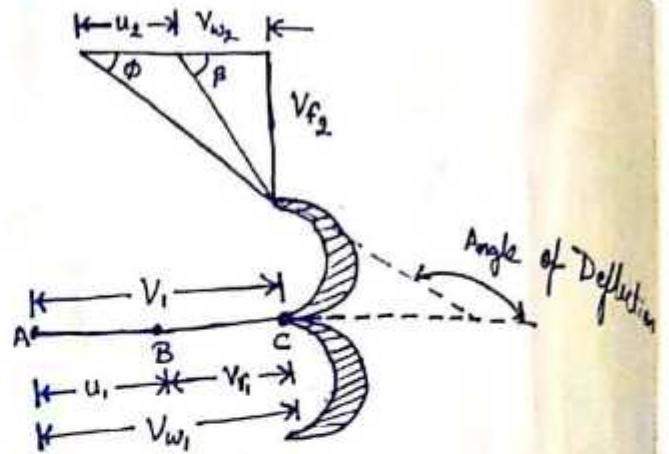
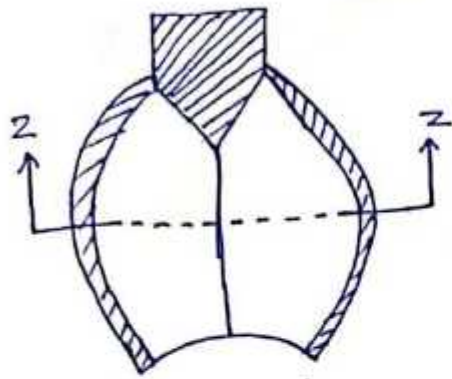
3. Casing: The function of casing is to prevent the splashing of water and to discharge water to tail race. It also acts as Safeguard against accidents. It is made of cast iron or fabricated steel plates



Pelton turbine.

4. Breaking Jet: When the nozzle is completely closed by moving the spear in forward direction, the amount of water striking the runner reduces to zero. But the runner due to inertia goes on revolving for a long time. To stop the runner in a short time, a small nozzle is provided which directs the jet of water on the back of vanes known as brake jet.

Velocity triangle and Work done for Pelton Wheel



Let $H =$ Net head acting on the Pelton Wheel
 $= H_g - h_f$

where $H_g =$ Gross Head and $h_f = \frac{4fLV^2}{D_p \times 2g}$

$D_p =$ Diameter of Penstock $N =$ Speed of wheel in r.p.m

$D =$ Diameter of wheel $d =$ Diameter of jet of water

$$V_1 = \text{Velocity of jet at inlet} = \sqrt{2gH}$$

$$u = u_1 = u_2 = \frac{\pi DN}{60}$$

The velocity triangle at inlet will be a straight line

$$V_{r1} = V_1 - u_1 = V_1 - u$$

$$V_{w1} = V_1$$

$$\alpha = 0^\circ \text{ \& } \theta = 0^\circ$$

From velocity triangle at outlet

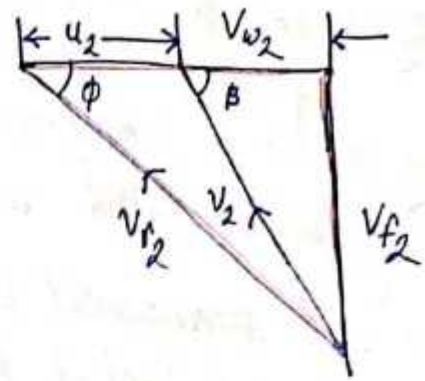
$$V_{r1} = V_{r2}$$

In the outlet triangle

$$\cos \phi = \frac{u_2 + V_{w2}}{V_{r2}}$$

$$\Rightarrow V_{r2} \cos \phi = u_2 + V_{w2}$$

$$\Rightarrow V_{w2} = V_{r2} \cos \phi - u_2$$



Force exerted by the jet of water in the direction of motion (F_x) = $\rho a V_1 [V_{w1} + V_{w2}]$

As the angle β is an acute angle, +ive sign is taken.

Also in case of series of vane the mass of water striking is $\rho a V_1$ and not $\rho a V_{r1}$.

$$\text{Area of the jet } (a) = \frac{\pi}{4} d^2$$

Work done by the jet on the runner per second = $F_x \times u$

$$= \rho a V_1 [V_{w1} + V_{w2}] \times u \text{ Nm/s}$$

Power given to the runner by the jet = $\frac{\rho a V_1 [V_{w1} + V_{w2}] \times u}{1000} \text{ kW}$

1000

Work done/s per unit weight of water striking/s = $\frac{\rho a V_1 [V_{w1} + V_{w2}] \times u}{\rho a V_1 \times g}$

$$= \frac{\rho a V_1 [V_{w1} + V_{w2}] u}{\rho a V_1 \times g}$$

$$= \frac{\text{weight of water striking/s}}{g} (V_{w1} + V_{w2}) u \quad \text{--- (1)}$$

Working of Pelton Turbine:

- The water is transferred from the high head source through a long conduit called Penstock.
- Nozzle arrangement at the end of penstock helps the water to accelerate and it flows out as a high speed jet with high velocity and discharged at atmospheric pressure.
- The jet will hit the splitter of the bucket which will distribute the jet into two halves of bucket and the wheel starts revolving.
- The kinetic energy of the jet is reduced when it hits the bucket and also due to spherical shape of buckets the directed jet will change its direction and takes U-turn and falls into tail race.
- In general the inlet angle of jet is in between 1° to 3° , after hitting the buckets the deflected jet angle is in between 165° to 170° .

The energy supplied to the jet at inlet is in the form of kinetic energy $= \frac{1}{2} m v^2$

$$\therefore \text{K.E of jet per second} = \frac{1}{2} (\rho a v_1) \times v_1^2$$

$$\therefore \text{Hydraulic efficiency, } \eta_h = \frac{\text{Work done per second}}{\text{K.E of jet per second}}$$

$$= \frac{\rho a v_1 [v_{w1} + v_{w2}]}{\frac{1}{2} (\rho a v_1) \times v_1^2}$$

$$\eta_h = \frac{2 [v_{w1} + v_{w2}] \times u}{v_1^2} \quad \text{--- (2)}$$

as $v_{w1} = v_1$, $v_{r1} = v_1 - u = (v_1 - u) + v_{r1} = v_{r2}$

$$v_{r2} = (v_1 - u)$$

$$v_{w2} = v_{r2} \cos \phi - u = v_{r2} \cos \phi - u = (v_1 - u) \cos \phi - u$$

Substituting the values of v_{w1} and v_{w2} in the equation (2)

$$\eta_h = \frac{2 [v_1 + (v_1 - u) \cos \phi - u] \times u}{v_1^2}$$

$$= \frac{2 [(v_1 - u) + (v_1 - u) \cos \phi] \times u}{v_1^2}$$

$$\eta_h = \frac{2 (v_1 - u) [1 + \cos \phi] u}{v_1^2} \quad \text{--- (3)}$$

The efficiency will be maximum for a given value of V_1 when

$$\frac{d(\eta_h)}{du} = 0 \quad \text{or} \quad \frac{d}{du} \left[\frac{2u(V_1 - u)(1 + \cos\phi)}{V_1^2} \right] = 0$$

$$\text{or} \quad \frac{(1 + \cos\phi)}{V_1^2} \frac{d}{du} (2uV_1 - 2u^2) = 0$$

$$\text{or} \quad \frac{d}{du} (2uV_1 - 2u^2) = 0 \quad \left(\because \frac{1 + \cos\phi}{V_1^2} = 0 \right)$$

$$\Rightarrow 2V_1 - 4u = 0$$

$$\Rightarrow 2V_1 = 4u$$

$$\Rightarrow \boxed{u = \frac{V_1}{2}}$$

Hence the hydraulic efficiency of a pelton wheel will be maximum when the velocity of the wheel is half the velocity of the jet of water at inlet.

$$\begin{aligned} \therefore \text{Max. } \eta_h &= \frac{2 \left(V_1 - \frac{V_1}{2} \right) (1 + \cos\phi) \times \frac{V_1}{2}}{V_1^2} \\ &= \frac{2 \times \left(\frac{V_1 - V_1}{2} \right) (1 + \cos\phi) \frac{V_1}{2}}{V_1^2} \end{aligned}$$

$$\boxed{\text{Max } \eta_h = \frac{(1 + \cos\phi)}{2}}$$

Points to Remember for Pelton Wheel:

(i) Vel of the jet at inlet $V_1 = C_v \sqrt{2gH}$

where C_v = Co-efficiency of Velocity = 0.98 or 0.99

H = Net head

(ii) ϕ = speed ratio varies from 0.43 to 0.48

(iii) The angle of deflection of the jet through buckets is taken as 165° .
if no angle of deflection is given

(iv) $u = \frac{\pi D N}{60}$ or $D = \frac{60u}{\pi N}$

where D = mean diameter or pitch diameter of Pelton wheel

(v) Jet Ratio: It is defined as the ratio of the pitch diameter (D) of the Pelton wheel to the diameter of jet (d)

$$m = \frac{D}{d} = \frac{\text{Pitch diameter of the Pelton wheel}}{\text{Diameter of jet}}$$

(vi) Number of buckets on a runner is given by

$$Z = 15 + \frac{D}{2d} = 15 + 0.5m$$

where m = Jet ratio

(vii) Number of jets = $\frac{\text{Total rate of flow through the turbine}}{\text{Rate of flow of water through a single jet}}$

Difference between Impulse and Reaction Turbine:

Impulse Turbine

1. If at the inlet of the turbine the energy available is only kinetic energy, the turbine is known as impulse turbine.
2. This type of turbine consists of moving blades and nozzles.
3. Efficiency is low.
4. It occupies less space per unit power.
5. The blades are symmetrical.
6. Maintenance is easy here.
7. There is no draft tube here.
8. The unit is installed above the tail race.
9. It operates at higher water head.
10. An example of impulse turbine is Pelton wheel turbine.

Reaction Turbine

1. If at inlet of the turbine, the water possesses kinetic energy as well as pressure energy, the turbine is known as reaction turbine.
2. Reaction turbine consists of fixed blades that act as a moving blades and a nozzle.
3. Efficiency is high.
4. It occupies more space per unit power.
5. The blades are not symmetrical.
6. Maintenance of these turbine is not easy here.
7. In reaction turbine there is draft tube.
8. The unit is installed below the tailrace that means completely submerged in water.
9. It operates at lower or medium water head.
10. An example of reaction turbine is the Kaplan Turbine and Francis Turbine.

Q A Pelton wheel has a mean bucket speed of 10 m/s with a jet of water flowing at the rate of 700 litres under a head of 30m. The buckets deflect the jet through an angle of ~~10~~ 160° . Calculate the power given by water to the runner and hydraulic efficiency of the turbine. Assume co-efficient of velocity as 0.98.

Given

Speed of bucket $u = u_1 = u_2 = 10 \text{ m/s}$

Discharge $Q = 700 \text{ lt/s} = 0.7 \text{ m}^3/\text{s}$

Head of water $H = 30 \text{ m}$

Angle of deflection $= 160^\circ$

\therefore Angle $\phi = 180 - 160 = 20^\circ$

Co-efficient of velocity $C_v = 0.98$

Velocity of jet $V_1 = C_v \sqrt{2gH} = 0.98 \sqrt{2 \times 9.81 \times 30}$
 $= 23.77 \text{ m/s}$

$V_{r1} = V_1 - u_1 = 23.77 - 10 = 13.77 \text{ m/s}$

$V_{w1} = V_1 = 23.77 \text{ m/s}$

Outlet velocity triangle $V_{r2} = V_{r1} = 13.77 \text{ m/s}$

$V_{w2} = V_{r2} \cos \phi - u_2$

$= 13.77 \cos 20 - 10$

$= 2.94 \text{ m/s}$

$$\begin{aligned} \text{Work done by the jet per second on the runner} &= \rho a V_1 [V_{w1} + V_{w2}] u \\ &= 1000 \times 0.7 [23.77 + 2.94] \times 10 \\ &= 186970 \text{ Nm/s} \quad (\because aV = Q = 0.7 \text{ m}^3/\text{s}) \end{aligned}$$

$$\therefore \text{Power given to turbine} = \frac{186970}{1000} = 186.97 \text{ kW}$$

$$\begin{aligned} \text{Hydraulic efficiency of the turbine } (\eta_h) &= \frac{2[V_{w1} + V_{w2}] u}{V_1^2} \\ &= \frac{2(23.77 + 2.94) \times 10}{23.77 \times 23.77} \\ &= 0.9454 \\ &= 94.54\% \end{aligned}$$

Q. A pelton wheel is to be designed for the following specifications:
 Shaft power = 11772 kW; Head = 380 m; speed = 750 r.p.m; Overall efficiency = 86%.
 Jet diameter is not to exceed one-sixth of the wheel diameter. Determine
 (i) The wheel diameter (ii) The number of jets required
 (iii) Diameter of the jet Take $K_{w1} = 0.985$ and $K_{u1} = 0.45$
 $C_v = 0.985$ and speed ratio = 0.45

Solⁿ

Given: Shaft power S.P = 11772 kW

Head $H = 380 \text{ m}$

Speed $N = 750 \text{ r.p.m}$

Overall efficiency $\eta_o = 86\%$ or 0.86

Ratio of jet dia to wheel dia. $\frac{d}{D} = \frac{1}{6}$

C_o - efficient of velocity $K_v = C_v = 0.985$

Speed ratio $K_u = 0.45$

Velocity of jet $V_1 = C_v \sqrt{2gH} = 0.985 \sqrt{2 \times 9.81 \times 380} = 85.05 \text{ m/s}$

Velocity of wheel $u = u_1 = u_2$

$u = \text{speed ratio} \times \sqrt{2gH} = 0.45 \times \sqrt{2 \times 9.81 \times 380}$
 $= 38.85 \text{ m/s}$

$u = \frac{\pi D N}{60} = \frac{\pi D 750}{60}$

$\Rightarrow 38.85 = \frac{\pi D 750}{60}$

$\Rightarrow D = \frac{38.85 \times 60}{\pi \times 750} = 0.989 \text{ m}$

As $\frac{d}{D} = \frac{1}{6}$

\therefore Dia of jet $d = \frac{1}{6} \times D = \frac{0.989}{6} = 0.165 \text{ m}$

Discharge of one jet $(q) = \text{Area of jet} \times \text{Vel. of jet}$

$= \frac{\pi}{4} d^2 \times V_1 = \frac{\pi}{4} \times (0.165)^2 \times 85.05 \text{ m}^3/\text{s}$
 $= 1.818 \text{ m}^3/\text{s}$

$\eta_o = \frac{\text{S.P.}}{\text{W.P.}} = \frac{11772}{\frac{\rho g Q H}{1000}}$

$\Rightarrow 0.86 = \frac{11772 \times 1000}{1000 \times 9.81 \times Q \times 380}$

(where $Q = \text{Total discharge}$)

\therefore Total discharge $Q = \frac{11772 \times 1000}{0.86 \times 9.81 \times 380} = 3.672 \text{ m}^3/\text{s}$

$$\therefore \text{No. of jets} = \frac{\text{Total discharge}}{\text{Discharge of one jet}} = \frac{Q}{q} = \frac{3.672}{1.818} = 2 \text{ jets}$$

Francis Turbine:

- The inward flow reaction turbine having radial discharge at outlet is known as Francis Turbine.
- It is after the name of J. B Francis an American Engineer.
- In modern Francis Turbine, the water enters the runner of turbine in the radial direction at outlet and leaves in the axial direction at the inlet of runner.
- Thus Modern Francis Turbine is a mixed flow type turbine.

As in case of Francis turbine the discharge is radial at outlet

$$\therefore \text{Whirl velocity at outlet} = V_{w2} = 0 \text{ and } \beta = 90^\circ$$

$$\text{Work done by water on the runner per second} = \rho Q [V_{w1} u_1]$$

$$\text{Work done per second per unit weight of water striking/s} = \frac{1}{g} [V_{w1} u_1]$$

$$\text{Hydraulic efficiency } \eta_h = \frac{V_{w1} u_1}{gH}$$

Important Relations for Francis Turbine:

1. The ratio of width of wheel to its diameter is given as $n = \frac{B_1}{D_1}$
 n varies from 0.10 to 0.40.

2. Flow ratio = $\frac{V_{f1}}{\sqrt{2gH}}$ varies from 0.15 to 0.30.

3. Speed ratio = $\frac{u_1}{\sqrt{2gH}}$ varies from 0.6 to 0.9.

Q A Francis turbine with an overall efficiency of 75% is required to produce 148.25 kW power. It is working under a head of 7.62 m. The peripheral velocity = $0.26\sqrt{2gH}$ and the radial velocity of flow at inlet is $0.96\sqrt{2gH}$. The wheel runs at 150 rpm and the hydraulic losses in the turbine are 22% of the available energy. Assuming radial discharge, determine:

- (i) The guide vane angle (ii) The wheel vane angle at inlet
(iii) Diameter of the wheel at inlet (iv) Width of the wheel at inlet

Solⁿ:

Given:

Overall Efficiency

$$\eta_o = 75\% = 0.75$$

Power produced

$$S.P = 148.25 \text{ kW}$$

Head

$$H = 7.62 \text{ m}$$

Peripheral Velocity

$$u_1 = 0.26\sqrt{2gH} = 0.26\sqrt{2 \times 9.81 \times 7.62} = 3.179 \text{ m/s}$$

Velocity of flow at inlet

$$V_{f1} = 0.96\sqrt{2gH} = 0.96\sqrt{2 \times 9.81 \times 7.62} = 11.738 \text{ m/s}$$

Speed

$$N = 150 \text{ r.p.m}$$

Hydraulic losses = 22% of available energy

Discharge at outlet = Radial

$$V_{w2} = 0 \text{ and } V_{f2} = V_2, \beta = 90^\circ$$

$$\text{Hydraulic efficiency } (\eta_h) = \frac{\text{Total head at inlet} - \text{Hydraulic loss}}{\text{Head at inlet}}$$

$$= \frac{H - 0.22H}{H} = \frac{0.78H}{H} = 0.78$$

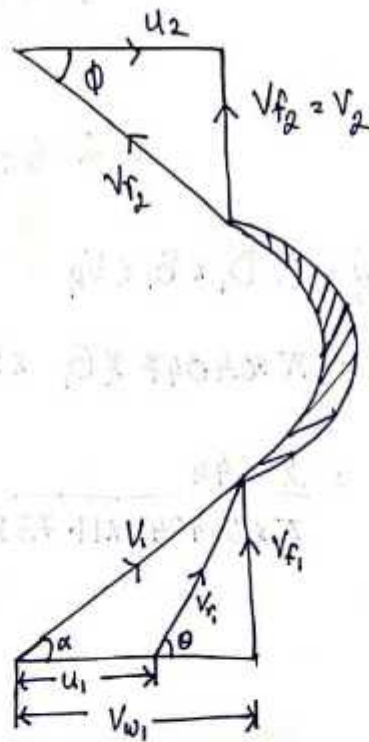
$$\eta_h = \frac{V_{w1} u_1}{gH}$$

$$\therefore 0.78 = \frac{V_{w1} u_1}{gH}$$

$$\therefore V_{w1} = \frac{0.78 \times g \times H}{u_1}$$

$$= \frac{0.78 \times 9.81 \times 7.62}{31.79}$$

$$= 18.34 \text{ m/s}$$



(i) The guide blade angle i.e. α .

$$\tan \alpha = \frac{V_f}{V_{w1}} = \frac{11.738}{18.34} = 0.64$$

$$\Rightarrow \alpha = \tan^{-1} 0.64 = 32.619$$

(ii) The wheel vane angle at inlet i.e. θ

$$\tan \theta = \frac{V_f}{V_{w1} - u_1} = \frac{11.738}{18.34 - 3.179} = 0.774$$

$$\theta = \tan^{-1} 0.774 = 37.74^\circ$$

(iii) Diameter of wheel at inlet (D_1)

$$u_1 = \frac{\pi D_1 N}{60}$$

$$D_1 = \frac{60 \times u_1}{\pi \times N} = \frac{60 \times 3.179}{\pi \times 50} = 0.4047 \text{ m}$$

(iv) width of the wheel at inlet (B_1)

$$\eta_o = \frac{S.P.}{W.P.} = \frac{148.25}{W.P.}$$

$$\Rightarrow W.P. = \frac{WH}{1000} = \frac{\rho \times g \times Q \times H}{1000} = \frac{1000 \times 9.81 \times Q \times 7.62}{1000}$$

$$\therefore \eta_o = \frac{148.25}{\frac{1000 \times 9.81 \times Q \times 7.62}{1000}} = \frac{148.25}{9.81 \times Q \times 7.62}$$

$$= 2.644 \text{ m}^3/\text{s}$$

$$Q = \pi D_1 \times B_1 \times V_f$$

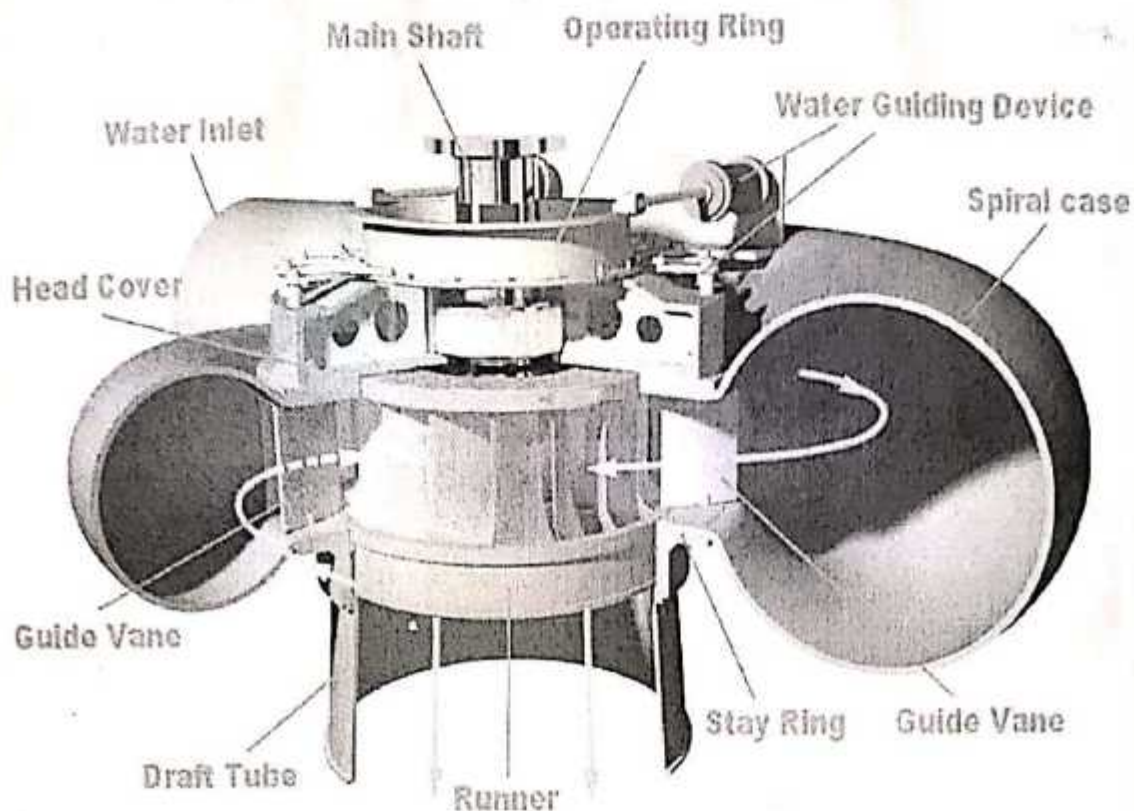
$$\Rightarrow 2.644 = \pi \times 0.4047 \times B_1 \times 11.738$$

$$\Rightarrow B_1 = \frac{2.644}{\pi \times 0.4047 \times 11.738} = 0.177 \text{ m}$$



Main Components of Francis Turbine:

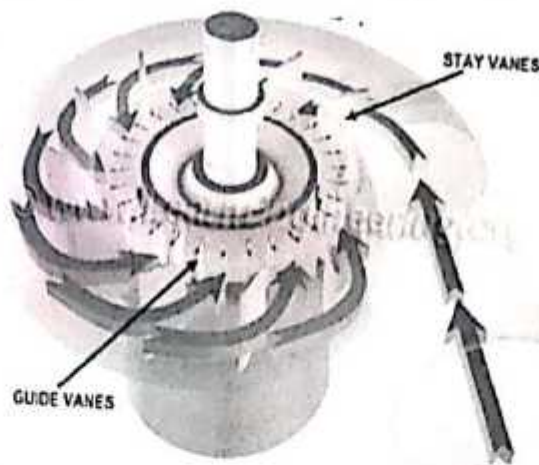
1. Spiral Casing: Spiral casing is the inlet medium of water to the turbine. The water flowing from the reservoir or dam is made to pass through this pipe with high pressure.



Francis Turbine

The blades of the turbine are circularly placed which means the water striking the turbine's blades should flow in the circular axis for efficient striking. But due to circular movement of the water it loses its pressure & to maintain pressure drop the diameter of casing is gradually reduced.

2. Stay Vanes: Stay vanes and guide vanes guide the water to the runner blades. Stay vanes remain stationary at their position and reduce the swirling of water due to the radial flow as it enters the runner blades.



Stay Vanes and guide Vanes of Francis Turbine.

3. Guide Vanes: Guide vanes are stationary, they change their angle as per the requirement to control the angle of striking of water to turbine blades to increase the efficiency and also regulate the flow rate water into the runner blades.
4. Runner Blades: These are arranged at the centre of the turbine. Where the water hits and the tangential power of impact causes the shaft to turn for generating torque.
5. Draft Tube: The water at exit cannot be directly discharged to the tail race. A tube or pipe of gradually ~~increase~~ increasing area is used for discharging water from the exit of the turbine to the tail race known as draft tube.

Working of Francis Turbine:

The water enters into the turbine through volute casing and then to the guide blades and stationary blades.

The volute casing keeps in reducing diameter to maintain the flow pressure.

The stationary blades remain fixed at their position, which eliminates the water vortices.

The guide blade's angle determines the angle of the water on the impeller blades ~~and~~ and ensures the performance of turbine.

The water flows through the guide blades or guide vanes and is directed towards the runner blades at optimum angles.

Since the water crosses the precisely curved blades of the runner the water is diverted somewhat sideways to create "Whirl motion".

The water is then deflected in the axial direction to exit a draft tube to the tail race.

A Francis turbine with an overall efficiency of 75% is required to produce 148.25 kW power. It is working under a head of 7.62 m.

The Peripheral velocity = $0.26\sqrt{2gH}$ and the radial velocity of flow at inlet is $0.96\sqrt{2gH}$. The wheel runs at 150 r.p.m and the hydraulic losses in the turbine are 22% of the available energy. Assuming radial discharge, determine:

- (i) The guide blade angle (ii) The wheel vane angle at inlet
 (iii) Diameter of the wheel at inlet (iv) Width of the wheel at inlet.

Solution:

Given:

Overall efficiency $\eta_o = 75\% = 0.75$

Power produced S.P = 148.25 kW

Head $H = 7.62$ m

Peripheral Velocity $u_1 = 0.26\sqrt{2gH} = 0.26 \times \sqrt{2 \times 9.81 \times 7.62} = 3.179$ m/s

Velocity of flow at inlet $V_{f1} = 0.96\sqrt{2gH} = 0.96 \times \sqrt{2 \times 9.81 \times 7.62} = 11.738$ m/s

Speed $N = 150$ r.p.m

Hydraulic losses = 22% of available energy

As discharge at outlet is radial.

$$\Rightarrow V_{w2} = 0$$

$$V_{f2} = V_2$$

Hydraulic efficiency is given as

$$\eta_h = \frac{\text{Total head at inlet} - \text{Hydraulic Losses}}{\text{Head at inlet}}$$

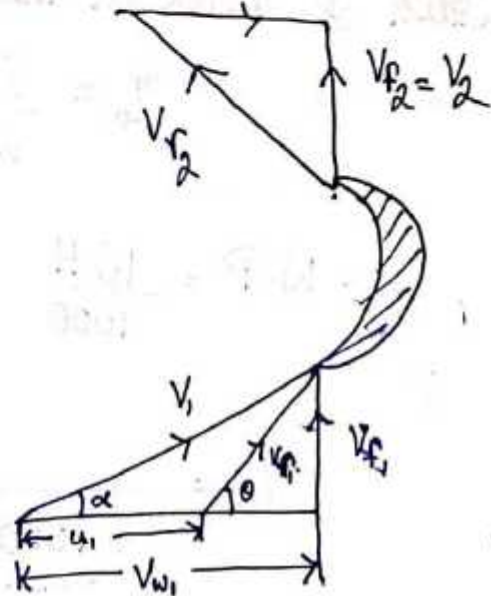
$$\eta_h = \frac{H - 0.22H}{H} = \frac{0.78H}{H}$$

But we know $\eta_h = \frac{V_{w1} u_1}{gH}$

$$\Rightarrow \frac{V_{w1} u_1}{gH} = 0.78$$

$$\Rightarrow V_{w1} = \frac{0.78 \times g \times H}{u_1}$$

$$= \frac{0.78 \times 9.81 \times 7.62}{3.179} = 18.34 \text{ m/s}$$



(i) Guide blade angle i.e. α

$$\tan \alpha = \frac{V_{f1}}{V_{w1}} = \frac{11.738}{18.34} = 0.64$$

(ii) The wheel vane angle at inlet i.e. θ

$$\tan \theta = \frac{V_{f1}}{V_{w1} - u_1} = \frac{11.738}{18.34 - 3.179} = 0.774$$

$$\theta = \tan^{-1} 0.774 = 37.74$$

(iii) Diameter of wheel at inlet (D_1)

$$u_1 = \frac{\pi D_1 N}{60}$$

$$D_1 = \frac{60 \times u_1}{\pi N} = \frac{60 \times 3.179}{\pi \times 50} = 0.4047 \text{ m}$$

(iv) Width of wheel at inlet (B_1)

$$\eta_o = \frac{S.P}{W.P} = \frac{148.25}{W.P}$$

$$W.P = \frac{WH}{1000} = \frac{\rho g QH}{1000} = \frac{1000 \times 9.81 \times Q \times 7.62}{1000}$$

$$\eta_o = \frac{148.25}{\frac{1000 \times 9.81 \times Q \times 7.62}{1000}} = \frac{148.25}{9.81 \times Q \times 7.62}$$

$$Q = \frac{148.25}{9.81 \times 7.62 \times 0.75} = 2.644 \text{ m}^3/\text{s}$$

$$Q = \pi D_1 B_1 V_f$$

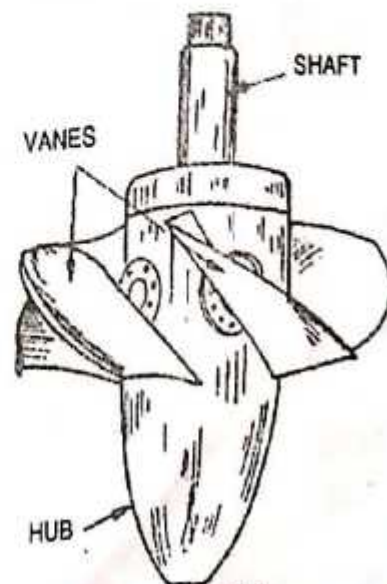
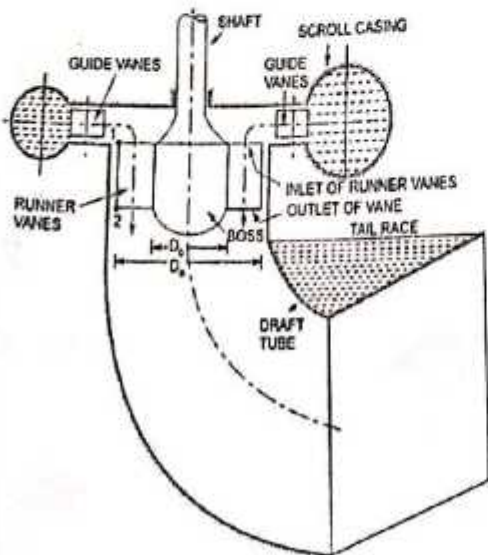
$$\Rightarrow 2.644 = \pi \times 0.4047 \times B_1 \times 11.738$$

$$\Rightarrow B_1 = \frac{2.644}{\pi \times 0.4047 \times 11.738} = 0.177 \text{ m}$$

Kaplan Turbine: Kaplan turbine is axial flow reaction turbine in which water flows parallel to the axis of rotation of the shaft and head at the inlet of the turbine is the sum of pressure energy and kinetic energy and during the flow of water through runner a part of pressure energy is converted into kinetic energy.

- Kaplan turbine was named after the name of V Kaplan an Austrian Engineer.
- The axial flow reaction have vertical shaft and the lower end of the shaft is made larger which is known as 'hub' or 'boss'.
- The vanes on the hub are adjustable in Kaplan turbine.
- Kaplan Turbine is suitable for large quantity of water low head.
- The main parts of Kaplan turbine are:

1. Scroll casing: It is a spiral type of casing with ~~re~~ reducing cross-sectional area. The water from the penstock enters the scroll cover and then into the guide vane, where the water passes 90° and flows axially through the runner.



Guide Vanes: It is the only controlled part of the entire turbine, which opens and closes depending on the demand for electricity required. When greater power generation is required it opens wider to allow more water to hit the rotor blades and vice-versa happens for low power output.

Hub with vanes or runner of the turbine: The runner of this turbine has a large 'boss' or hub with its vanes mounted on it. The vanes of the runner are adjustable to an optimum angle of attack for maximum power output.

Draft Tube: A tube or pipe of a slowly growing area is used to discharge water from the exit of the turbine to the tailrace known as ~~drop~~ draft tube.

Working of Kaplan Turbine:

- The water is poured into the scroll casing before the penstock. The cross-section of the scroll casing decreases evenly to maintain water pressure.
- Then with scroll casing the guide vanes transport the water to the runner or vanes. The vanes or runner are adjustable to maintain optimal angle for the varying flow rates.
- From the runner blades water enters the draft tube, where the kinetic and pressure energy of the turbine decreases.

• Kinetic energy is converted into pressure energy, which leads to increase water pressure and finally water discharge from the turbine through the tail race.

• The runner rotates the rotation shaft of the blade to which the runner blades are attached.

• This rotation of the shaft is used for power generation.

Q A Kaplan turbine working under a head of 20 m develops 11772 kW shaft power. The outer diameter of the runner is 3.5 m and hub diameter 1.75 m. The guide blade angle at the extreme edge of the runner is 35° . The hydraulic and overall efficiencies of the turbine are 88% and 84% respectively. If the velocity of whirl is zero at outlet, determine:

- Runner vane angle at inlet and outlet at the extreme edge of the runner
- Speed of turbine.

Given :

Head $H = 20\text{ m}$

Shaft power $S.P = 11772\text{ kW}$

Outer diameter of runner $D_o = 3.5\text{ m}$

Hub diameter $D_b = 1.75\text{ m}$

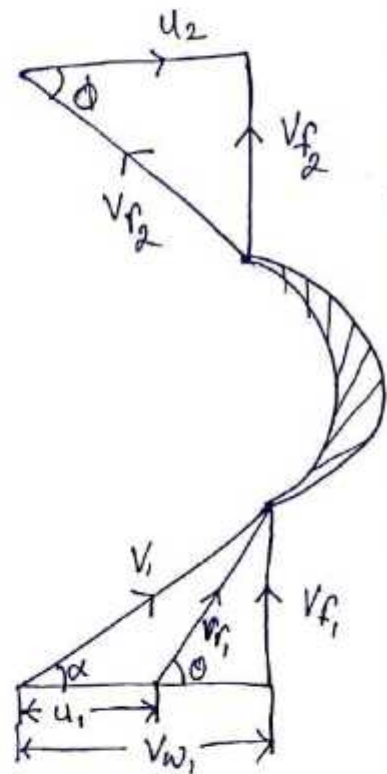
Guide blade angle $\alpha = 35^\circ$

Hydraulic efficiency $\eta_h = 88\%$

Overall efficiency $\eta_o = 84\%$

$$\eta_o = \frac{S.P}{W.P}$$

$$W.P = \frac{W.P}{1000} = \frac{\rho \times g \times Q \times H}{1000}$$



$$\Rightarrow 0.84 = \frac{11772}{\frac{\gamma \times g \times Q \times H}{1000}}$$

$$= \frac{11772 \times 1000}{1000 \times 9.81 \times Q \times 20} \quad (\because \rho = 1000)$$

$$Q = \frac{11772 \times 1000}{0.84 \times 1000 \times 9.81 \times 20} = 71.428 \text{ m}^3/\text{s}$$

$$Q = \frac{\pi}{4} (D_o^2 - D_b^2) \times V_f$$

$$\Rightarrow 71.428 = \frac{\pi}{4} (3.5^2 - 1.75^2) \times V_f = \frac{\pi}{4} (12.25 - 3.0625) V_f$$

$$\Rightarrow 71.428 = 7.216 V_f$$

$$\Rightarrow V_f = \frac{71.428}{7.216} = 9.9 \text{ m/s}$$

inlet velocity triangle, $\tan \alpha = \frac{V_f}{V_{w1}}$

$$V_{w1} = \frac{V_f}{\tan \alpha} = \frac{9.9}{\tan 35^\circ} = \frac{9.9}{0.7} = 14.4 \text{ m/s}$$

Hydraulic Efficiency, η_h

$$\eta_h = \frac{V_{w1} \cdot u_1}{gH} \quad (\because V_{w2} = 0)$$

$$0.88 = \frac{14.4 \times u_1}{9.81 \times 20}$$

$$u_1 = \frac{0.88 \times 9.81 \times 20}{14.4} = 12.21 \text{ m/s}$$

(i) Runner vane angles at inlet & outlet at the extreme edge of the runner

$$\tan \theta = \frac{V_{f1}}{V_{w1} - u_1} = \frac{9.9}{14.14 - 12.21} = 5.13$$

$$\theta = \tan^{-1} 5.13 = 78.97^\circ$$

$$u_1 = u_2 = 12.21 \text{ m/s} \quad \& \quad V_{f1} = V_{f2} = 9.9 \text{ m/s}$$

\therefore From outlet velocity triangle, $\tan \phi = \frac{V_{f2}}{u_2} = \frac{9.9}{12.21} = 0.811$

$$\phi = \tan^{-1} 0.811 = 39.035^\circ$$

(ii) Speed of turbine is given by $u_1 = u_2 = \frac{\pi D_o N}{60}$

$$12.21 = \frac{\pi \times 3.5 \times N}{60}$$

$$\Rightarrow N = \frac{60 \times 12.21}{\pi \times 3.5} = 66.63 \text{ rpm.}$$

Centrifugal Pumps

Pumps: The hydraulic machines which convert the mechanical energy into hydraulic energy are called pump.

Centrifugal Pump: If the mechanical energy is converted into pressure energy by means of centrifugal force acting on the fluid, the hydraulic machine is called centrifugal pump. The centrifugal pump acts as a reverse of an inward radial flow reaction turbine. Therefore the flow in centrifugal pumps is in the radial outward directions. It is used in places like agriculture, municipal (water & wastewater plant), industrial, power generation plants, Petroleum, mining, pharmaceutical etc.

Main parts of Centrifugal Pump:

The following are the main parts of a centrifugal pump:

1. Impeller
2. Casting
3. Suction pipe with a foot valve and a strainer
4. Delivery pipe.

Centrifugal Pumps

Pumps: The hydraulic machines which convert the mechanical energy into hydraulic energy are called pump.

Centrifugal Pump: If the mechanical energy is converted into pressure energy by means of centrifugal force acting on the fluid, the hydraulic machine is called centrifugal pump. The centrifugal pump acts as a reverse of an inward radial flow reaction turbine.

Therefore the flow in centrifugal pumps is in the radial outward directions. It is used in places like agriculture, municipal (water & wastewater plant), industrial, power generation plants, Petroleum, mining, pharmaceutical etc.

Main parts of Centrifugal Pump:

The following are the main parts of a centrifugal pump:

1. Impeller
2. Casting
3. Suction pipe with a foot valve and a strainer
4. Delivery pipe.

1. Impeller: The rotating part of a centrifugal pump is called 'impeller'. It consists of a series of backward curved vanes. The impeller is mounted on a shaft which is connected to the shaft of an electric motor.

2. Casing: The casing of centrifugal pump is similar to reaction turbine. It is an air-tight passage surrounding the impeller and is designed is such a that kinetic energy of the water discharged at the outlet of the impeller is converted into pressure energy before the water leaves the casing and enters the delivery pipe.

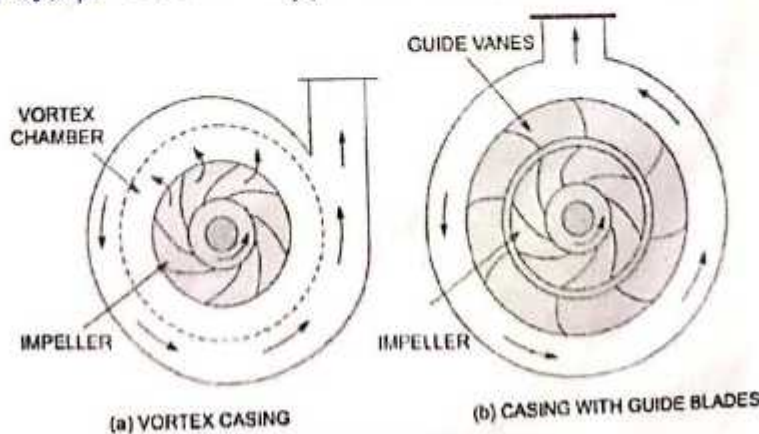
The following three types of the casing are commonly adopted:

(a) Volute Casing

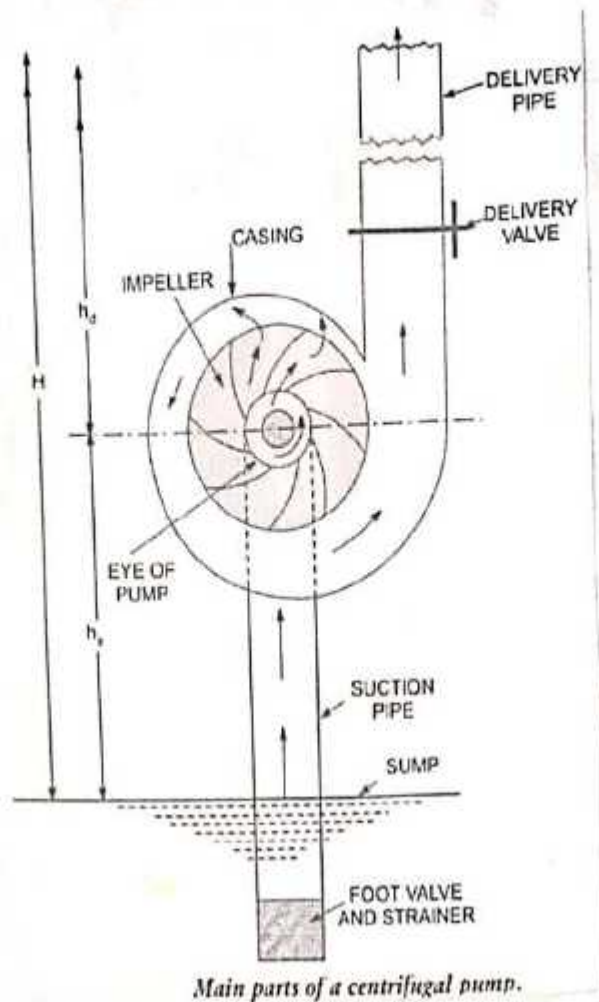
(b) Vortex Casing

(c) Casing with guide blades

(a) Volute Casing: Volute casing, which surrounds the impeller. It is spiral type in which area of flow increases gradually and velocity of flow decreases. The decrease in velocity increases the pressure of the water flowing through the casing.



Different types of casing.



(b) Vortex Casing: If a circular chamber is introduced between the casing and the impeller as shown in figure 2.1 the casing is known as vortex casing. Because of circular chamber the loss of energy due to formation of eddies is reduced to a considerable extent. Hence efficiency is more as compared to volute casing.

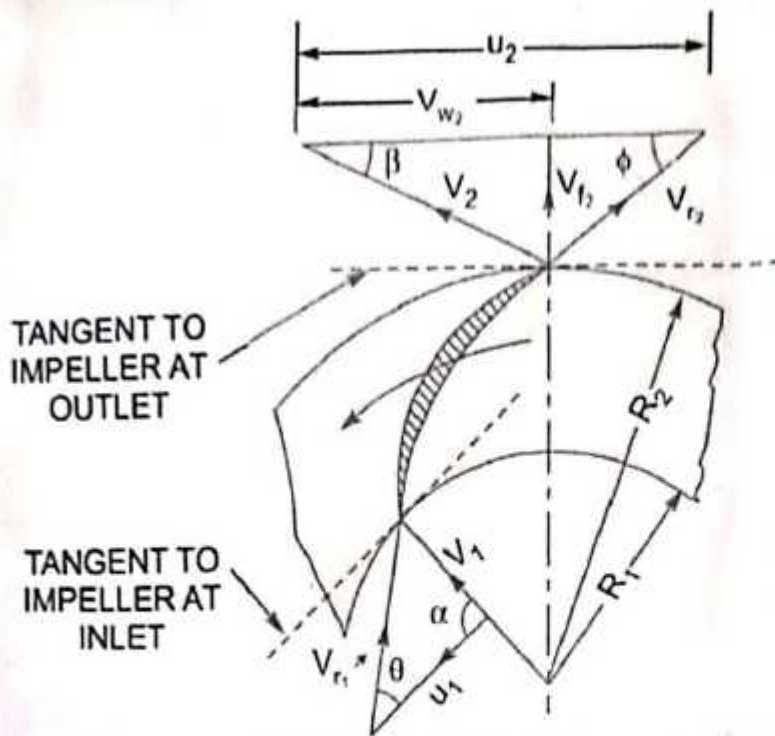
(c) Casing with Guide Blades: As shown in fig 2.1 in which the impeller is surrounded by a series of guide blade mounted on ring known as diffuser. The guide vanes are designed in such a way that the water from the impeller enters the guide vanes without shock.

3. Suction pipe with a foot valve and a strainer: A pipe whose one end is connected to the pump and the other end dip into water in a sump known as suction pipe. A foot valve which acts as a non-return valve and opens only upwards is fitted at the lower end of the suction pipe. A strainer is also fitted at the lower end of suction pipe.

4. Delivery Pipe: A pipe whose one end is connected to the outlet of the pump and other end delivers the water at a required height known as delivery pipe.

Working of Centrifugal Pump:

- A Centrifugal pump uses a centrifugal force to pump the fluids ~~hence~~ hence known as Centrifugal pump.
- Two mechanical power is given by electric motor to the impeller.
- The impeller directly connects with the electric motor through a shaft and reciprocates with the motion of the motor shaft.
- When the impeller starts rotating, a vacuum starts generating inside the impeller's eye. Due to this vacuum the water starts entering from the sump through the suction pipe to the impeller.
- As the water enters in the impeller eye, the water strikes the blades of the impeller.
- The impeller rotates the water radially and axially outward with the help of Centrifugal force.
- Since the impeller is moving at high velocity it also rotates the water around it.
- The area of casing increases slowly in the direction of rotation, so as the water velocity decreases and pressure increases, the pressure at the outlet of the pump is maximized.
- From the outlet of the pump the water goes through the delivery pipe to its intended location.



Let N = Speed of the impeller in rpm

D_1 = Diameter of impeller at inlet

u_1 = Tangential velocity of impeller at inlet = $\frac{\pi D_1 N}{60}$

D_2 = Diameter of impeller at outlet

u_2 = Tangential velocity of impeller at outlet = $\frac{\pi D_2 N}{60}$

V_1 = Absolute velocity of water at inlet

α = Angle made by absolute velocity (V_1) at inlet with the direction of motion of vane

θ = Angle made by relative velocity at inlet with the direction of motion of vane and V_1

V_2 , β and ϕ the corresponding values at outlet.

As the water enters the impeller radially which means the absolute velocity of water at inlet is in the radial direction and hence angle $\alpha = 90^\circ$ and $V_{w1} = 0$

A centrifugal pump is the reverse of a ~~small~~ radially inward flow reaction turbine

$$\therefore \text{Water striking per second} = \frac{1}{g} [V_{w1} u_1 - V_{w2} u_2]$$

\therefore Work done by the impeller on the water per second per unit weight of water striking per second = - [work done in case of turbine]

$$= - \left[\frac{1}{g} (V_{w1} u_1 - V_{w2} u_2) \right]$$

$$= \frac{1}{g} [V_{w2} u_2 - V_{w1} u_1]$$

$$= \frac{1}{g} V_{w2} u_2 \quad (\because V_{w1} = 0)$$

$$\text{Work done by impeller on water per second} = \frac{W}{g} V_{w2} u_2$$

where $W = \text{weight of water} = \rho g Q$

$Q = \text{Volume of water}$

$$Q = \text{Area} \times \text{Velocity of flow} = \pi D_1 B_1 V_{f1}$$
$$= \pi D_2 B_2 V_{f2}$$

where B_1 and B_2 are width of impeller at inlet and outlet.

Definitions of Heads and efficiencies of a Centrifugal Pump

1. Suction Head (h_s): It is the vertical height of the centre line of the centrifugal pump ~~are~~ above the water surface in the tank or pump from which the water is to be lifted.
2. Delivery Head (h_d): The vertical distance between the centre lines of the pump and the water surface in the tank to which water is delivered known as delivery head.
3. Static Head (H_s): The sum of suction head and delivery head is known as static head.

$$H_s = h_s + h_d$$

4. Manometric Head (H_m): The manometric head is defined as the head against which a centrifugal pump has to work.

(a) $H_m = \text{Head imparted by the impeller to water} - \text{Loss of head in the pump}$

$$H_m = \frac{V_{w2} u_2}{g} - \text{Loss of head in impeller + casing}$$

(b) $H_m = \text{Total head at outlet of the pump} - \text{Total head at the inlet of Pump}$

$$H_m = \left(\frac{P_o}{\rho g} + \frac{V_o^2}{2g} + Z_o \right) - \left(\frac{P_i}{\rho g} + \frac{V_i^2}{2g} + Z_i \right)$$

where $\frac{P_o}{\rho g}$ = Pressure head at outlet of the pump = h_d

$\frac{V_o^2}{2g}$ = Velocity head at outlet of the pump

$\frac{V_d^2}{2g}$ = Velocity head at delivery pipe

Z_o = Vertical height of the ~~exit~~ outlet of the pump from datum line

$\frac{P_i}{\rho g}$, $\frac{V_i^2}{2g}$, Z_i = Corresponding values of pressure head, velocity head and datum head at the inlet of the pump

$$(c) H_m = h_s + h_d + h_{fs} + h_{fd} + \frac{V_d^2}{2g}$$

where h_s = Suction head, h_d = Delivery head

h_{fs} = Frictional head loss in suction pipe, h_{fd} = Frictional head loss in delivery pipe

V_d = Velocity of water in delivery pipe

5. Efficiencies of Centrifugal Pump:

(a) Manometric efficiency, η_{man}

(b) Mechanical efficiency, η_m

(c) Overall efficiency, η_o

(a) Manometric Efficiency (η_{man}): The ratio of the manometric head to the head imparted by the impeller to the water is known as manometric efficiency.

$$\eta_{man} = \frac{\text{Manometric head}}{\text{Head imparted by impeller to water}}$$

$$\eta_{man} = \frac{H_m}{\left(\frac{V_{w2} U_2}{g}\right)} = \frac{g H_m}{V_{w2} U_2}$$

$$\eta_{man} = \frac{g H_m}{V_{w2} U_2}$$

The ratio of the power given to water at outlet of the pump to the pump to the power available at the impeller is known as manometric efficiency.

$$\text{Power given to water at outlet of pump} = \frac{W H_m}{1000} \text{ kW}$$

$$\text{Power at the impeller} = \frac{\text{Work done by impeller per sec}}{1000} \text{ kW}$$

$$\eta_{man} = \frac{\frac{W H_m}{1000}}{\frac{W}{g} \times \frac{V_{w2} U_2}{1000}} = \frac{g H_m}{V_{w2} U_2}$$

(b) Mechanical Efficiency (η_m): The power at the shaft of the centrifugal pump is more than the power available at the impeller of the pump.

The ratio of power available at the impeller to the power at the shaft of the centrifugal pump is known as mechanical efficiency.

$$\eta_m = \frac{\text{Power at the impeller}}{\text{Power at the shaft}}$$

$$\begin{aligned} \text{The power at the impeller in kW} &= \frac{\text{work done by impeller per sec}}{1000} \\ &= \frac{W}{g} \times \frac{V_{u2} U_2}{1000} \end{aligned}$$

$$\eta_m = \frac{\frac{W}{g} \left(\frac{V_{u2} U_2}{1000} \right)}{\text{S.P}}$$

(c) Overall Efficiency (η_o): It is defined as ratio of power output of the pump to the power input to the pump.

$$\begin{aligned} \text{power output of the pump in kW} &= \frac{\text{weight of water lifted} \times H_m}{1000} \\ &= \frac{WH_m}{1000} \end{aligned}$$

Power input to the pump = Power supplied by the electric motor
= S.P of the pump

$$\eta_o = \frac{WH_m}{1000 \text{ S.P}}$$

$$\eta_o = \eta_{man} \times \eta_m$$

Q. The internal and external diameters of the ~~inlet~~ impeller of a centrifugal pump are 200mm and 400mm respectively. The pump is running at 1200 rpm. The vane angle of the impeller at inlet and outlet are 20° and 30° respectively. The water enters the impeller radially and velocity of flow is constant. Determine the work done by the impeller per unit weight of water.

Sol: Given:

Internal diameter of impeller, $D_1 = 200\text{mm} = 0.2\text{m}$

External diameter of impeller, $D_2 = 400\text{mm} = 0.4\text{m}$

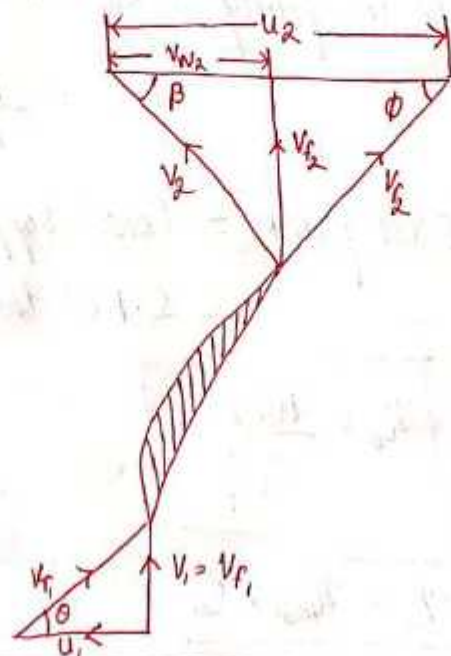
Speed $N = 1200\text{rpm}$

Vane angle at inlet, $\theta = 20^\circ$

Vane angle at outlet, $\phi = 30^\circ$

Water enters radially $\Rightarrow \alpha = 90^\circ$ & $V_{w1} = 0$

Velocity of flow $V_{f1} = V_{f2}$



Tangential velocity of impeller at inlet and outlet are

$$u_1 = \frac{\pi D_1 N}{60} = \frac{\pi \times 0.2 \times 1200}{60} = 12.56 \text{ m/s}$$

$$u_2 = \frac{\pi D_2 N}{60} = \frac{\pi \times 0.4 \times 1200}{60} = 25.13 \text{ m/s}$$

From inlet velocity triangle $\tan \theta = \frac{V_{f1}}{u_1} = \frac{V_{f1}}{12.56}$

$$V_{f1} = 12.56 \tan \theta = 12.56 \times \tan 20^\circ = 4.57 \text{ m/s}$$

$$V_{f2} = V_{f1} = 4.57 \text{ m/s}$$

Outlet velocity triangle, $\tan \phi = \frac{V_{f2}}{u_2 - V_{w2}} = \frac{4.57}{\tan 30^\circ} = 7.915$

$$V_{w2} = 25.13 - 7.915 = 17.215 \text{ m/s}$$

The work done by impeller per kg of water per second

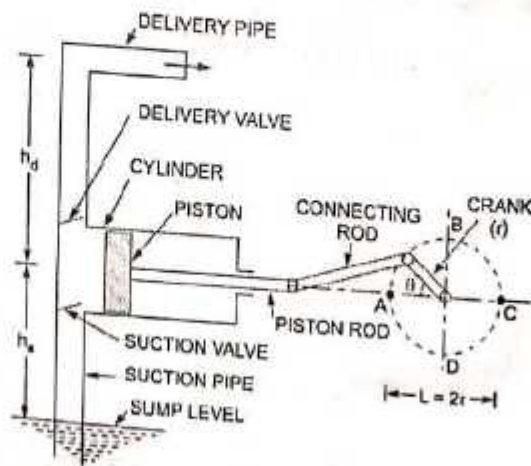
$$= \frac{1}{g} V_{w2} u_2 = \frac{17.215 \times 25.13}{9.81} = 44.17 \text{ Nm/N}$$

Reciprocating Pump

Reciprocating Pump: If the mechanical energy is converted into hydraulic energy (or pressure energy) by sucking the liquid into a cylinder in which a piston is reciprocating (moving backward and forwards) which exerts the thrust on the liquid and increases its hydraulic energy (pressure energy) the pump is known as reciprocating pump.

Main Parts of a Reciprocating Pump: The following are main parts of reciprocating pump:

1. A Cylinder with a piston, piston rod, connecting rod + crank.
2. Suction Pipe.
3. Delivery Pipe.
4. Suction Valve.
5. Delivery Valve.



Main parts of a reciprocating pump.

Working of a Reciprocating Pump:

- In fig 3.1 shows a single acting reciprocating pump which consists of a piston which moves forward and backward in a close fitting cylinder.
- The movement of the piston is obtained by connecting the piston rod to crank by means of connecting rod.
- The crank is rotated by means of an electric motor.
- Suction and Delivery pipes are attached with suction valve & delivery valves are connected to the cylinder.
- The suction and delivery valves are non-return valves, which allows the water to flow in one direction only.
- As the crank starts rotating from A to C (i.e from $\theta = 0^\circ$ to $\theta = 180^\circ$) the piston starts moving towards right in the cylinder.
- Due to the movement of the piston towards right creates a partial vacuum in the cylinder.
- But on the surface of the liquid in the sump atmospheric pressure is acting which is more than the pressure inside the cylinder.
- Thus the liquid is forced in the suction pipe from the sump.
- Hence the suction valve opens and liquid enters the cylinder.
- When crank is rotating from C to A (i.e from $\theta = 180^\circ$ to $\theta = 360^\circ$) the piston from its extreme right position starts moving towards the left in the cylinder.
- The movement of the piston towards left increases the pressure of the liquid inside the cylinder more than atmospheric pressure.
- Hence suction valve closes and delivery valve opens.
- The liquid is forced into the delivery pipe and is raised to a required height.

Discharge Through a Reciprocating Pump:

Let us consider a single acting reciprocating pump as shown in Fig 3.1

Let D = Diameter of the cylinder.

$$A = \text{Cross-sectional area of the piston or cylinder} \\ = \frac{\pi}{4} D^2$$

r = Radius of crank.

N = r.p.m of the crank.

L = Length of the stroke = $2r$

h_s = Height of the axis of the cylinder from water surface in sump

h_d = Height of delivery outlet above the cylinder axis (known as delivery head)

Volume of water delivered in one revolution or

$$\text{Discharge of water in one revolution} = A \times L \times \text{Length of stroke} \\ = A \times L$$

$$\text{Number of revolution per second} = \frac{N}{60}$$

\therefore Discharge of the pump per second,

$$Q = \text{Discharge in one revolution} \times \text{No. of revolution per sec} \\ = A \times L \times \frac{N}{60}$$

$$= \frac{ALN}{60}$$

Weight of water delivered per second,

$$W = \rho g Q = \frac{\rho g A L N}{60}$$

Work done by Reciprocating Pump:

Work done by reciprocating Pump per second = Weight lifted per second \times Total height through which water is lifted
 $= W \times (h_s + h_d)$ — (1)

where $(h_s + h_d)$ = Total height through which water is lifted

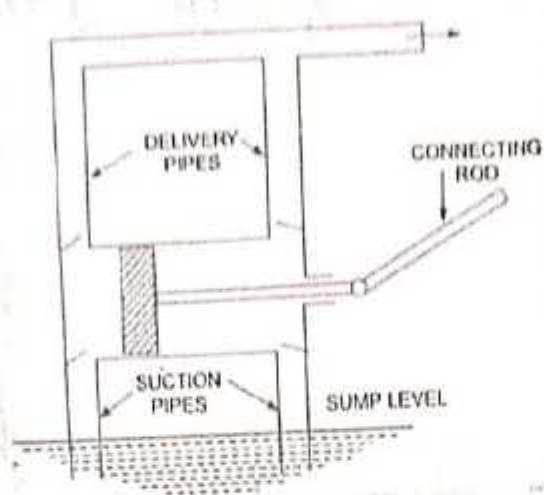
$$W (\text{weight}) = \frac{\rho g \times A L N}{60}$$

Substituting the value of W in equation (1) we have

$$\text{Work done per second} = \frac{\rho g \times A L N}{60} (h_s + h_d)$$

\therefore Power required to drive the pump in kW

$$P = \frac{\text{Work done per sec}}{1000} = \frac{\rho g \times A L N \times (h_s + h_d)}{60 \times 1000}$$
$$= \frac{\rho g \times A L N \times (h_s + h_d)}{60000} \text{ kW}$$



Discharge, work done and Power required to drive a double-acting Pump

- In double-acting reciprocating pump, the water is acting on both sides of the piston as shown in the figure given above
- Hence two suction pipes and two delivery pipes for double-acting pumps are required.
- When there is suction stroke on one side of the piston, there is at the same time a delivery stroke on the other side of the piston.
- In one complete revolution of the crank there are two delivery strokes and water is delivered to the pipes by the pump during these two delivery strokes.

Let D = Diameter of the piston ^{Discharge through a double acting Reciprocating Pump}

d = Diameter of the piston rod

$$\therefore \text{Area on one side of the Piston } (A) = \frac{\pi}{4} D^2$$

$$\text{Area on the other side of the piston } (A_1) = \frac{\pi}{4} D^2 - \frac{\pi}{4} d^2 \quad (\text{where piston rod is connected to the Piston})$$

$$\begin{aligned} \therefore \text{Volume of water delivered in one revolution of crank} \\ &= A \times \text{Length of stroke} + A_1 \times \text{Length of stroke} \\ &= AL + A_1 L = (A + A_1)L = \left[\frac{\pi}{4} D^2 + \frac{\pi}{4} (D^2 - d^2) \right] L \end{aligned}$$

$$\begin{aligned} \therefore \text{Discharge of Pump per second} &= \text{Volume of water delivered in one} \\ &\quad \text{revolution} \times \text{No. of revolution per second} \\ &= \left[\frac{\pi}{4} D^2 + \frac{\pi}{4} (D^2 - d^2) \right] \times L \times \frac{N}{60} \end{aligned}$$

If 'd' the diameter of the piston rod is very small as compared to the diameter of the piston, then it can be neglected and discharged

$$\begin{aligned} \text{Discharge of Pump per second } (Q) &= \left(\frac{\pi}{4} D^2 + \frac{\pi}{4} D^2 \right) \times \frac{L \times N}{60} \\ &= 2 \times \frac{\pi}{4} D^2 \times \frac{L N}{60} = \frac{2 \pi A L N}{60} \end{aligned}$$

$$\begin{aligned} \text{Work done by double acting reciprocating pump} &= \text{Weight of water} \\ &\quad \text{delivered} \times \text{Total height} \\ &= \rho g \times \text{Discharge per second} \times \text{Total Height} \end{aligned}$$

$$= \rho g \times \frac{2ALN}{60} \times (h_s + h_d)$$

$$Q = 2\rho g \times \frac{ALN}{60} \times (h_s + h_d)$$

\therefore Power required to drive the double-acting pump in kW (P) = $\frac{\text{Work done per second}}{1000}$

$$= \frac{2\rho g \times \frac{ALN}{60} \times (h_s + h_d)}{1000}$$

$$P = \frac{2\rho g \times ALN \times (h_s + h_d)}{60,000}$$

A single-acting reciprocating pump, running at 50 rpm, delivers $0.01 \text{ m}^3/\text{s}$ of water. The diameter of the piston is 200 mm and stroke length 400 mm.

Determine:

- (i) The theoretical discharge of the pump
- (ii) Co-efficient of discharge
- (iii) Slip and the percentage slip of the pump

Given:

Speed of the pump $N = 50 \text{ rpm}$

Actual discharge $Q_{\text{act}} = 0.01 \text{ m}^3/\text{s}$

Dia. of piston $D = 200 \text{ mm} = 0.2 \text{ m}$

\therefore Area $A = \frac{\pi}{4} (0.2)^2 = 0.031416 \text{ m}^2$

Stroke $L = 400 \text{ mm} = 0.4 \text{ m}$

(i) Theoretical discharge for single-acting reciprocating Pump

$$Q_{\text{th}} = \frac{ALN}{60} = \frac{0.031416 \times 0.4 \times 50}{60}$$

$$= 0.01047 \text{ m}^3/\text{s}$$

(ii) Co-efficient of discharge $C_d = \frac{Q_{\text{act}}}{Q_{\text{th}}} = \frac{0.01}{0.01047} = 0.955$

(iii) Slip $= Q_{\text{th}} - Q_{\text{act}} = 0.01047 - 0.01 = 0.00047 \text{ m}^3/\text{s}$

$$\% \text{ Slip} = \frac{Q_{\text{th}} - Q_{\text{act}}}{Q_{\text{th}}} \times 100 = \frac{(0.01047 - 0.01)}{0.01047} \times 100 = \frac{0.00047}{0.01047} \times 100 = 4.489\%$$

A double acting reciprocating pump, running at 40 rpm, is discharging 1.0 m^3 of water per min. The pump has a stroke of 400 mm. The diameter of the piston is 200 mm. The delivery and suction head are 20 m and 5 m respectively. Find the slip of the pump and power required to drive the pump.

Given : $N = 40 \text{ rpm}$

Actual discharge, $Q_{act} = 1.0 \text{ m}^3/\text{min} = \frac{1}{60} \text{ m}^3/\text{s} = 0.01666 \text{ m}^3/\text{s}$

Stroke $L = 400 \text{ mm} = 0.4 \text{ m}$

Diameter of piston (D) = 200 mm = 0.2 m

\therefore Area $(A) = \frac{\pi}{4} D^2 = \frac{\pi}{4} (0.2)^2 = 0.031416 \text{ m}^2$

Suction head, $h_s = 5 \text{ m}$

Delivery head, $h_d = 20 \text{ m}$

Theoretical discharge for double-acting pump is given by $(Q_{th}) = \frac{2ALN}{60}$

$$= \frac{2 \times 0.031416 \times 0.4 \times 40}{60} = 0.167 \text{ m}^3/\text{s}$$

Power required to drive the double-acting pump $(P) = \frac{2 \times \rho g \times ALN (h_s + h_d)}{60000}$

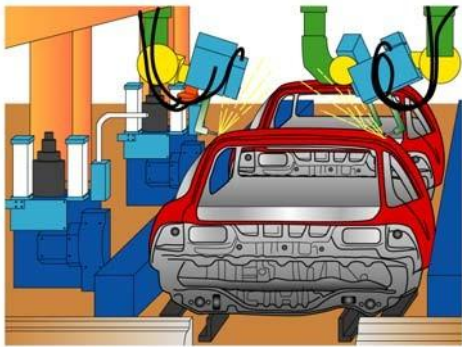
$$= \frac{2 \times 1000 \times 9.81 \times 0.031416 \times 0.4 \times 40 (5+20)}{60000}$$

$$= 4.109 \text{ kW}$$

Pneumatic Systems

1 Pneumatic systems

A pneumatic system is a system that uses compressed air to transmit and control energy. Pneumatic systems are used in controlling train doors, automatic production lines, mechanical clamps, etc (Fig. 1).



(a) Automobile production lines



(b) Pneumatic system of an automatic machine

Fig. 1 Common pneumatic systems used in the industrial sector

(a) The advantages of pneumatic systems

Pneumatic control systems are widely used in our society, especially in the industrial sectors for the driving of automatic machines. Pneumatic systems have a lot of advantages.

(i) High effectiveness

Many factories have equipped their production lines with compressed air supplies and movable compressors. There is an unlimited supply of air in our atmosphere to produce compressed air. Moreover, the use of compressed air is not restricted by distance, as it can easily be transported through pipes. After use, compressed air can be released directly into the atmosphere without the need of processing.

(ii) High durability and reliability

Pneumatic components are extremely durable and can not be damaged easily. Compared to electromotive components, pneumatic components are more durable and reliable.

(iii) Simple design

The designs of pneumatic components are relatively simple. They are thus more suitable for use in simple automatic control systems.

(iv) High adaptability to harsh environment

Compared to the elements of other systems, compressed air is less affected by high temperature, dust, corrosion, etc.

(v) Safety

Pneumatic systems are safer than electromotive systems because they can work in inflammable environment without causing fire or explosion. Apart from that, overloading in pneumatic system will only lead to sliding or cessation of operation. Unlike electromotive components, pneumatic components do not burn or get overheated when overloaded.

(vi) Easy selection of speed and pressure

The speeds of rectilinear and oscillating movement of pneumatic systems are easy to adjust and subject to few limitations. The pressure and the volume of air can easily be adjusted by a pressure regulator.

(vii) Environmental friendly

The operation of pneumatic systems do not produce pollutants. The air released is also processed in special ways. Therefore, pneumatic systems can work in environments that demand high level of cleanliness. One example is the production lines of integrated circuits.

(viii) Economical

As pneumatic components are not expensive, the costs of pneumatic systems are quite low. Moreover, as pneumatic systems are very durable, the cost of repair is significantly lower than that of other systems.

(b) Limitations of pneumatic systems

Although pneumatic systems possess a lot of advantages, they are also subject to many limitations.

(i) Relatively low accuracy

As pneumatic systems are powered by the force provided by compressed air, their operation is subject to the volume of the compressed air. As the volume of air may change when compressed or heated, the supply of air to the system may not be accurate, causing a decrease in the overall accuracy of the system.

(ii) Low loading

As the cylinders of pneumatic components are not very large, a pneumatic system cannot drive loads that are too heavy.

(iii) Processing required before use

Compressed air must be processed before use to ensure the absence of water vapour or dust. Otherwise, the moving parts of the pneumatic components may wear out quickly due to friction.

(iv) Uneven moving speed

As air can easily be compressed, the moving speeds of the pistons are relatively uneven.

(v) Noise

Noise will be produced when compressed air is released from the pneumatic components.

(c) Main pneumatic components

Pneumatic components can be divided into two categories:

1. Components that produce and transport compressed air.
2. Components that consume compressed air.

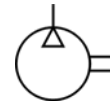
All main pneumatic components can be represented by simple pneumatic symbols. Each symbol shows only the function of the component it represents, but not its structure. Pneumatic symbols can be combined to form pneumatic diagrams. A pneumatic diagram describes the relations between each pneumatic component, that is, the design of the system.

2 The production and transportation of compressed air

Examples of components that produce and transport compressed air include compressors and pressure regulating components.

(a) Compressor

A compressor can compress air to the required pressures. It can convert the mechanical energy from motors and engines into the potential energy in compressed air (Fig. 2). A single central compressor can supply various pneumatic components with compressed air, which is transported through pipes from the cylinder to the pneumatic components. Compressors can be divided into two classes: reciprocating and rotary.



(a) Compressor used in schools (b) Compressor used in laboratories (c) Pneumatic symbol of a compressor

Fig. 2

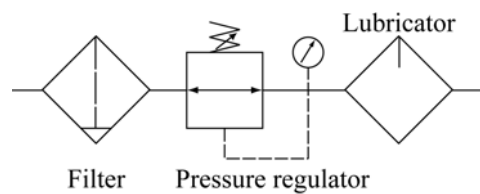
(b) Pressure regulating component

Pressure regulating components are formed by various components, each of which has its own pneumatic symbol:

- (i) Filter – can remove impurities from compressed air before it is fed to the pneumatic components.
- (ii) Pressure regulator – to stabilise the pressure and regulate the operation of pneumatic components
- (iii) Lubricator – To provide lubrication for pneumatic components



(a) Pressure regulating component



(b) Pneumatic symbols of the pneumatic components within a pressure regulating component

Fig. 3

3 The consumption of compressed air

Examples of components that consume compressed air include execution components (cylinders), directional control valves and assistant valves.

(a) Execution component

Pneumatic execution components provide rectilinear or rotary movement. Examples of pneumatic execution components include cylinder pistons, pneumatic motors, etc. Rectilinear motion is produced by cylinder pistons, while pneumatic motors provide continuous rotations. There are many kinds of cylinders, such as single acting cylinders and double acting cylinders.

(i) Single acting cylinder

A single acting cylinder has only one entrance that allows compressed air to flow through. Therefore, it can only produce thrust in one direction (Fig. 4). The piston rod is propelled in the opposite direction by an internal spring, or by the external force provided by mechanical movement or weight of a load (Fig. 5).

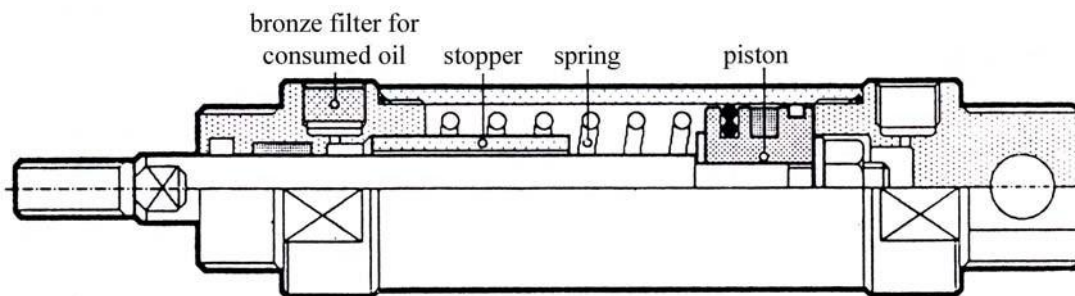
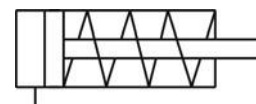


Fig. 4 Cross section of a single acting cylinder



Fig. 5 (a) Single acting cylinder



(b) Pneumatic symbol of a single acting cylinder

The thrust from the piston rod is greatly lowered because it has to overcome the force from the spring. Therefore, in order to provide the driving force for machines, the diameter of the cylinder should be increased. In order to match the length of the spring, the length of the cylinder should also be increased, thus limiting the length of the path. Single acting cylinders are used in stamping, printing, moving materials, etc.

(ii) Double acting cylinder

In a double acting cylinder, air pressure is applied alternately to the relative surface of the piston, producing a propelling force and a retracting force (Fig. 6). As the effective area of the piston is small, the thrust produced during retraction is relatively weak. The impecable tubes of double acting cylinders are usually made of steel. The working surfaces are also polished and coated with chromium to reduce friction.

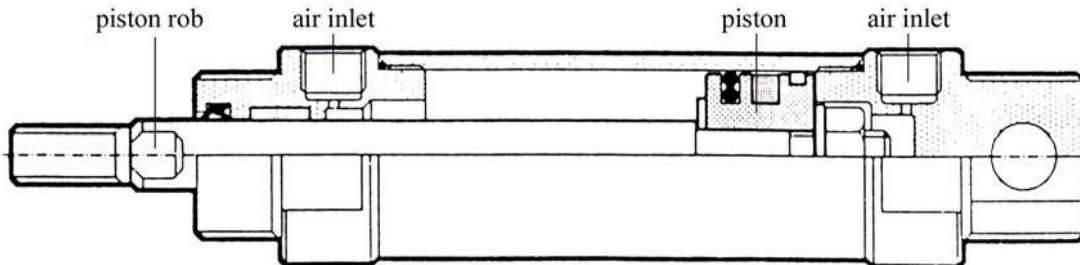
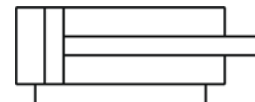


Fig. 6 Cross section of a double acting cylinder



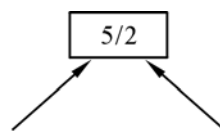
Fig. 7 (a) Double acting cylinder



(b) Pneumatic symbol of a double acting cylinder

(b) Directional control valve

Directional control valves ensure the flow of air between air ports by opening, closing and switching their internal connections. Their classification is determined by the number of ports, the number of switching positions, the normal position of the valve and its method of operation. Common types of directional control valves include 2/2, 3/2, 5/2, etc. The first number represents the number of ports; the second number represents the number of positions. A directional control valve that has two ports and five positions can be represented by the drawing in Fig. 8, as well as its own unique pneumatic symbol.



The number of ports The number of positions
Fig. 8 Describing a 5/2 directional control valve

(i) 2/2 Directional control valve

The structure of a 2/2 directional control valve is very simple. It uses the thrust from the spring to open and close the valve, stopping compressed air from flowing towards working tube 'A' from air inlet 'P'. When a force is applied to the control axis, the valve will be pushed open, connecting 'P' with 'A' (Fig. 9). The force applied to the control axis has to overcome both air pressure and the repulsive force of the spring. The control valve can be driven manually or mechanically, and restored to its original position by the spring.

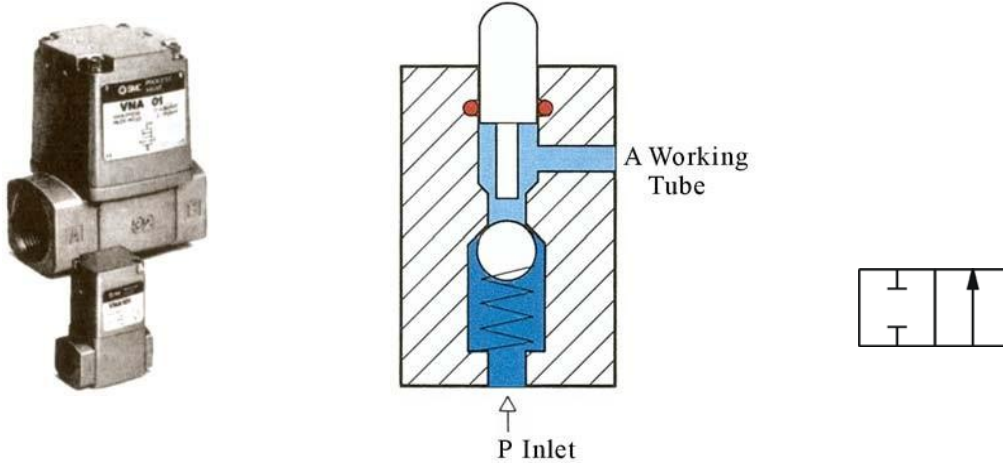


Fig. 9 (a) 2/2 directional control valve (b) Cross section (c) Pneumatic symbol of a 2/2 directional control valve

(ii) 3/2 Directional control valve

A 3/2 directional control valve can be used to control a single acting cylinder (Fig. 10). The open valves in the middle will close until 'P' and 'A' are connected together. Then another valve will open the sealed base between 'A' and 'R' (exhaust). The valves can be driven manually, mechanically, electrically or pneumatically. 3/2 directional control valves can further be divided into two classes: Normally open type (N.O.) and normally closed type (N.C.) (Fig. 11).

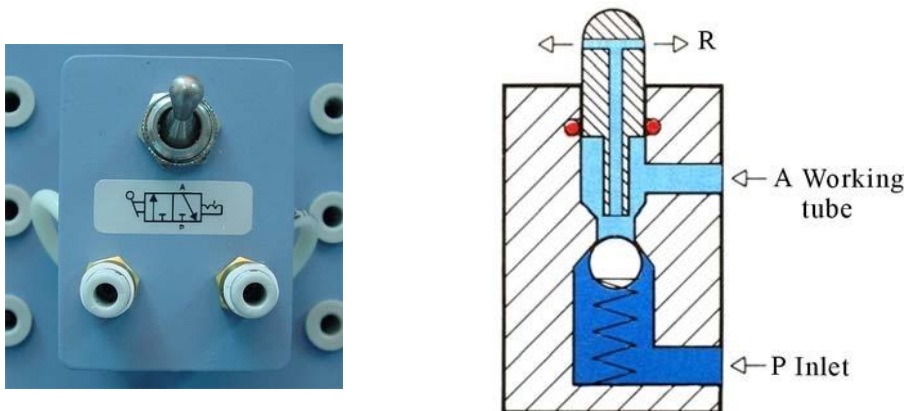
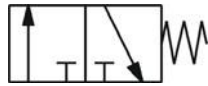


Fig. 10 (a) 3/2 directional control valve (b) Cross section



(a) Normally closed type

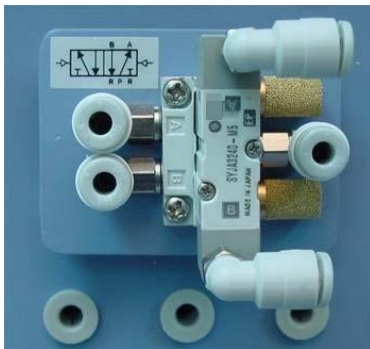


(b) Normally open type

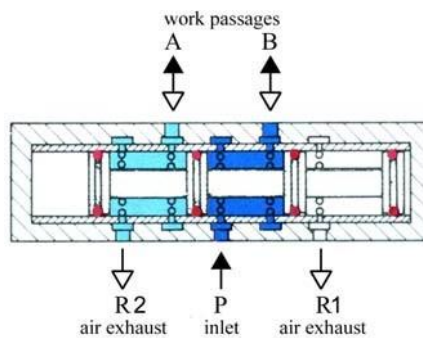
Fig. 11 Pneumatic symbols

(iii) 5/2 Directional control valve

When a pressure pulse is input into the pressure control port 'P', the spool will move to the left, connecting inlet 'P' and work passage 'B'. Work passage 'A' will then make a release of air through 'R1' and 'R2'. The directional valves will remain in this operational position until signals of the contrary are received. Therefore, this type of directional control valves is said to have the function of 'memory'.



(a) 5/2 directional control valve



(b) Cross section



(c) Pneumatic symbol

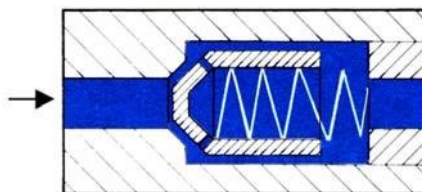
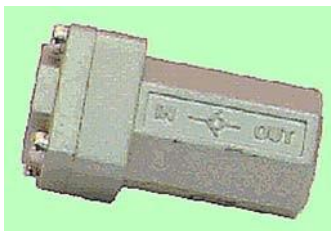
Fig. 12 5/2 directional control valve

(c) Control valve

A control valve is a valve that controls the flow of air. Examples include non-return valves, flow control valves, shuttle valves, etc.

(i) Non-return valve

A non-return valve allows air to flow in one direction only. When air flows in the opposite direction, the valve will close. Another name for non-return valve is poppet valve (Fig. 13).



(b) Cross section



(c) Pneumatic symbol

Fig. 13 (a) Non-return valve

(ii) Flow control valve

A flow control valve is formed by a non-return valve and a variable throttle (Fig. 14).

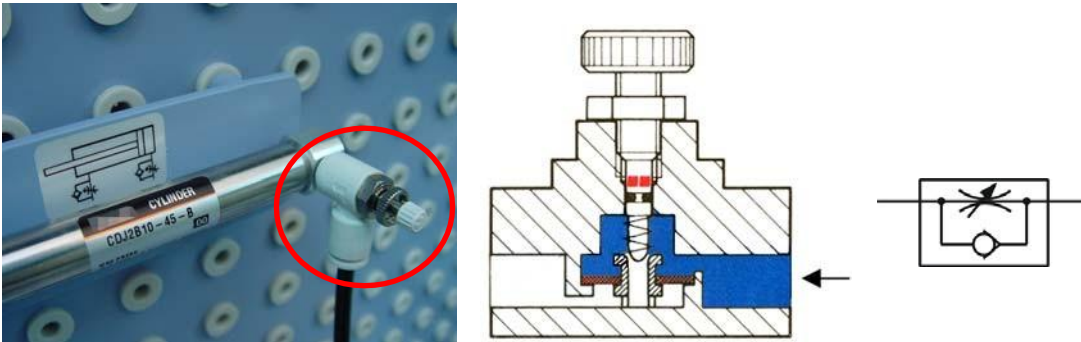


Fig. 14 (a) Flow control valve (b) Cross section (c) Pneumatic symbol

(iii) Shuttle valve

Shuttle valves are also known as double control or single control non-return valves. A shuttle valve has two air inlets 'P₁' and 'P₂' and one air outlet 'A'. When compressed air enters through 'P₁', the sphere will seal and block the other inlet 'P₂'. Air can then flow from 'P₁' to 'A'. When the contrary happens, the sphere will block inlet 'P₁', allowing air to flow from 'P₂' to 'A' only.

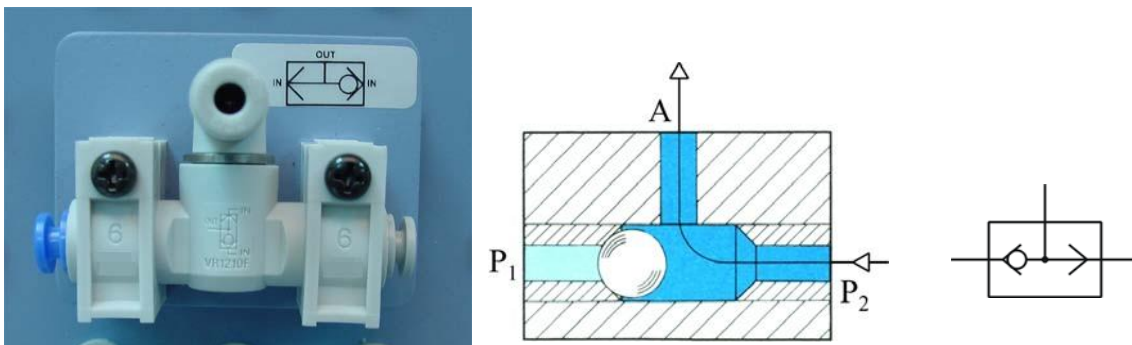


Fig. 15 (a) Shuttle valve (b) Cross section (c) Pneumatic symbol

4 Principles of pneumatic control

(a) Pneumatic circuit

Pneumatic control systems can be designed in the form of pneumatic circuits. A pneumatic circuit is formed by various pneumatic components, such as cylinders, directional control valves, flow control valves, etc. Pneumatic circuits have the following functions:

1. To control the injection and release of compressed air in the cylinders.
2. To use one valve to control another valve.

(b) Pneumatic circuit diagram

A pneumatic circuit diagram uses pneumatic symbols to describe its design. Some basic rules must be followed when drawing pneumatic diagrams.

(i) Basic rules

1. A pneumatic circuit diagram represents the circuit in static form and assumes there is no supply of pressure. The placement of the pneumatic components on the circuit also follows this assumption.
2. The pneumatic symbol of a directional control valve is formed by one or more squares. The inlet and exhaust are drawn underneath the square, while the outlet is drawn on the top. Each function of the valve (the position of the valve) shall be represented by a square. If there are two or more functions, the squares should be arranged horizontally (Fig. 16).

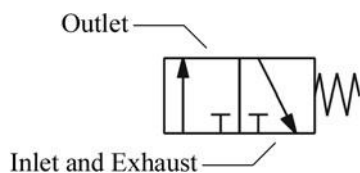


Fig. 16 3/2 directional control valve
(normally closed type)

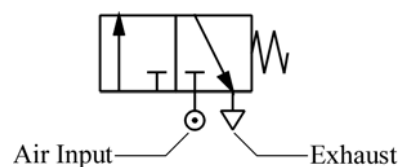


Fig 17 3/2 directional control valve
(normally closed type)

3. Arrows " \updownarrow " are used to indicate the flow direction of air current. If the external port is not connected to the internal parts, the symbol " \top " is used. The symbol " \odot " underneath the square represents the air input, while the symbol " ∇ " represents the exhaust. Fig. 17 shows an example of a typical pneumatic valve.
4. The pneumatic symbols of operational components should be drawn on the outside of the squares. They can be divided into two classes: mechanical and manual (Fig. 18 and 19).

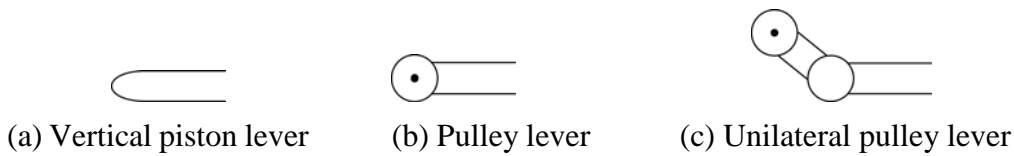


Fig. 18 Mechanically operated pneumatic components



Fig. 19 Manually operated pneumatic components

5. Pneumatic operation signal pressure lines should be drawn on one side of the squares, while triangles are used to represent the direction of air flow (Fig. 20).

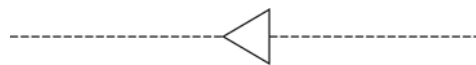


Fig. 20 Pneumatic operation signal pressure line

(ii) Basic principles

Fig. 21 shows some of the basic principles of drawing pneumatic circuit diagrams, the numbers in the diagram correspond to the following points:

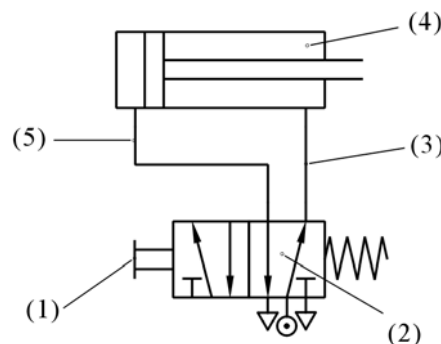


Fig. 21 Basic principles of drawing pneumatic circuit diagrams

1. When the manual switch is not operated, the spring will restore the valve to its original position.
2. From the position of the spring, one can deduce that the block is operating. The other block will not operate until the switch is pushed.
3. Air pressure exists along this line because it is connected to the source of compressed air.
4. As this cylinder cavity and piston rod are under the influence of pressure, the piston rod is in its restored position.
5. The rear cylinder cavity and this line are connected to the exhaust, where air is released.

(iii) The setting of circuit diagrams

When drawing a complete circuit diagram, one should place the pneumatic components on different levels and positions, so the relations between the components can be expressed clearly. This is called the setting of circuit diagrams. A circuit diagram is usually divided into three levels: power level, logic level and signal input level (Fig. 22).

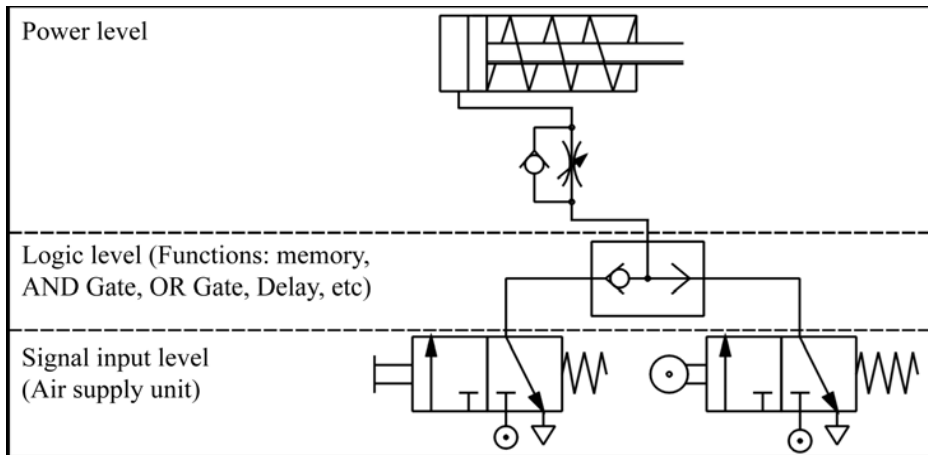
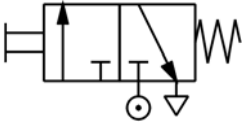


Fig. 22 Power level, logic level and signal input level

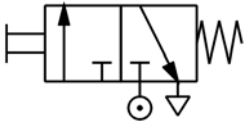
The basic rules of circuit diagram setting are as follows:

1.



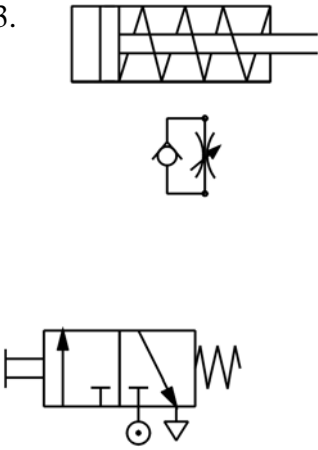
In a pneumatic circuit, the flow of energy is from the bottom to the top. Therefore, the air supply unit should be put at the bottom left corner.

2.



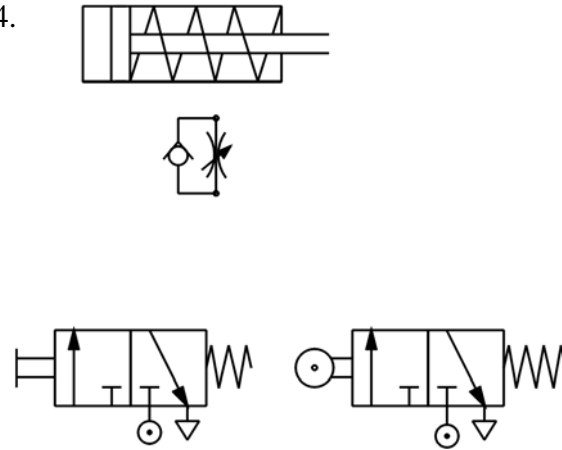
The work cycle should be drawn from left to right. The first operating cylinder should be placed at the upper left corner.

3.



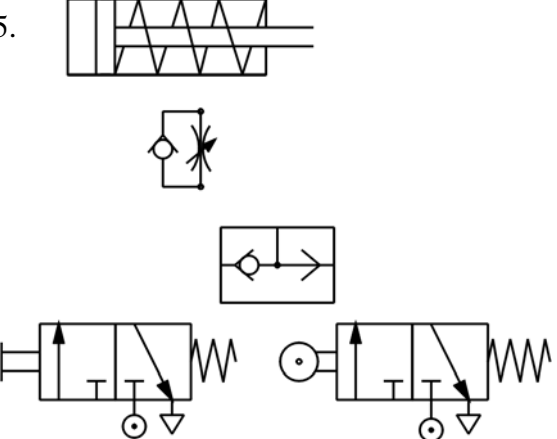
Power control valves should be drawn directly under the cylinder controlled by them, forming a power unit.

4.



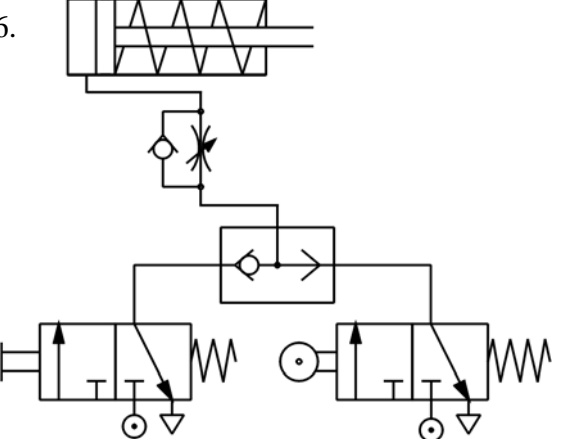
Control cylinders and operational valves (signal components) driven by power control valves should be placed at the lower levels of the diagram.

5.



Assistance valves, such as those with logic functions (for example, memory, 'AND', 'OR', 'NOT', delay, etc), can be put between the pneumatic components and the power control valves.

6.



Use the line which represents the connecting pipe to connect all the air supply unit and the pneumatic components to complete the pneumatic circuit. Check carefully the circuit and the logic of the operation before use to avoid any accident.

5 Different kinds of basic circuits

A basic circuit is a pneumatic circuit designed to perform basic tasks, such as flow amplification, signal inversion, memory, delay, single acting cylinder control, double acting cylinder control, etc.

(a) Flow amplification

Cylinders with a large capacity require a larger flow of air, which can be hazardous to users. It is unsafe to manually operate pneumatic directional control valves with large flow capacity. Instead we should first operate manually a small control valve and use it to operate the pneumatic control system with large flow capacity. This is called flow amplification, which can greatly ensure the safety of the operators. During operation, valves with large flow capacity should be placed near the cylinder, while valves with smaller flow capacity should be placed on control boards some distances away. Fig. 23 shows a basic flow amplification circuit. Notice how different components are placed on different levels.

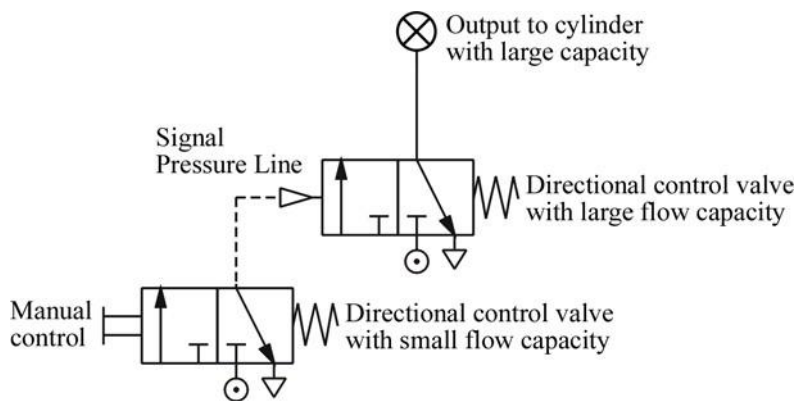


Fig. 23 Flow amplification system

(b) Signal inversion

The pneumatic diagram in Fig. 24 shows how directional control valves can be switched. When operating control valve ①, control valve ② will stop producing pressure output. When control valve ① ceases operation and is restored to its original position, control valve ② will resume its output. Therefore, at any given time, the pressure output of control valve ① is the exact opposite of that of control valve ②.

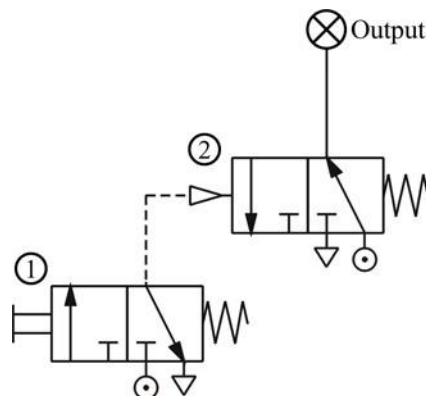


Fig. 24 Signal inversion system

(c) Memory Function

Memory is a common basic function. It can keep a component at a certain state permanently until there is a change of signals. Fig. 25 shows a memory function circuit. When control valve ① is operated momentarily (that is, pressed for a short time), the output signal of the 5/2 directional control valve ③ will be set to ON. The signal will stay that way until control valve ② is operated momentarily and generates another signal to replace it, causing it to stay permanently at OFF.

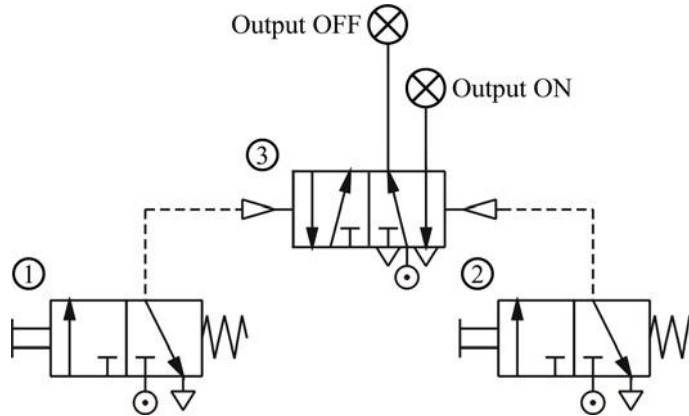


Fig. 25 Memory function circuit

(d) Delay function

A pneumatic delay circuit can delay the operating time of the next control valve. Its principle of operation involves the use of an orifice to slow down the flow of air and control the time of pneumatic operation. Delay functions can be divided into two classes: ON-signal delay and OFF-signal delay.

(i) ON-signal delay

Fig. 26 shows the circuit diagram of an ON-signal delay circuit, which delays the output of the next control valve. When control valve ① is operated, the one way flow control valve will slow down the flow of air, thus delaying the signal output of the outlet of control valve ② (A), resulting in a persistent ON-signal. The time when control valve ② will be restored to its original position is not affected.

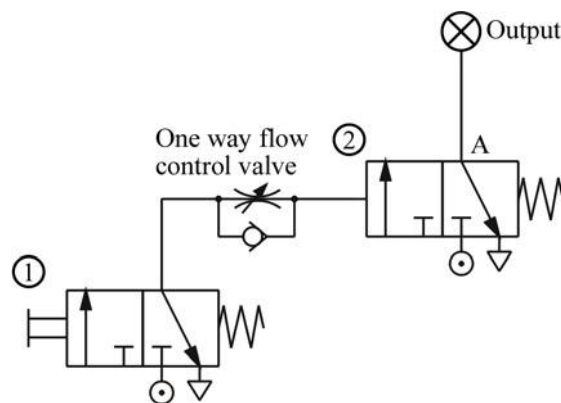


Fig. 26 Circuit diagram of an ON-signal delay circuit

(ii) OFF-signal Delay

Fig. 27 shows the circuit diagram of an OFF-signal delay circuit, which delays the output of the next control valve. This circuit is similar to an ON-signal delay circuit. The only difference is that the one way flow control valve is connected in the opposite direction. Therefore, when control valve ① is operated, the outlet of control valve ② (A) will continue to output signals. However, when control valve ② is restored to its original position, the release of air is slowed down by the one way flow control valve, resulting in a persistent OFF-signal.

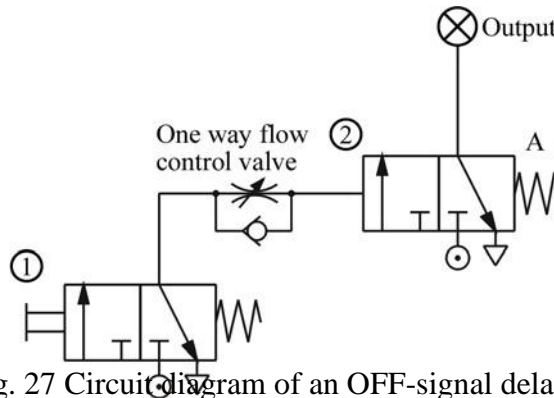


Fig. 27 Circuit diagram of an OFF-signal delay circuit

(e) Single acting cylinder control

Single acting cylinders can be controlled manually. However, they can also be controlled by two or more valves. This is called logic control. Examples of logic control include 'OR' function, 'AND' function, 'NOT' function, etc.

(i) Direct control and speed control

If a single acting cylinder is connected to a manual 3/2 directional control valve, when the control valve is operated, it will cause the cylinder to work (Fig. 28). Therefore, the circuit allows the cylinder to be controlled manually.

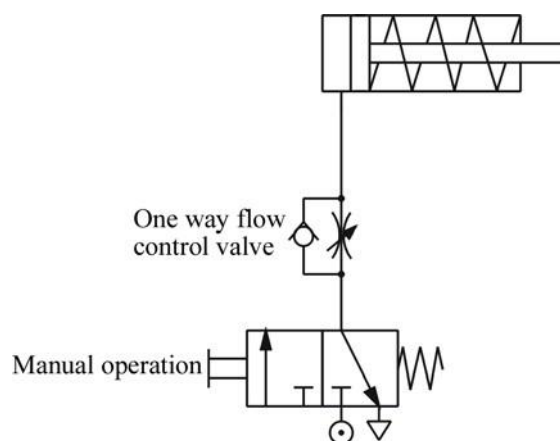


Fig. 28 Direct control of a single acting cylinder

The only way to change the extension speed of the piston of a single acting cylinder is to restrict the flow of air at the inlet and use the spring to determine the speed of retraction. Therefore, a one way flow control valve is placed in the circuit to control the speed.

(ii) OR Function

The single acting cylinder in Fig. 29 can be operated by two different circuits. Examples include manual operation and relying on automatic circuit signals, that is, when either control valve ① or control valve ② is operated, the cylinder will work. Therefore, the circuit in Fig. 29 possesses the OR function. However, if the output of two 3/2 directional control valves are connected through the port of a triode, the air current from control valve ① will be released through the exhaust of control valve ②, and so the cylinder will not work. This problem can be solved by connecting a shuttle valve to the port of the triode.

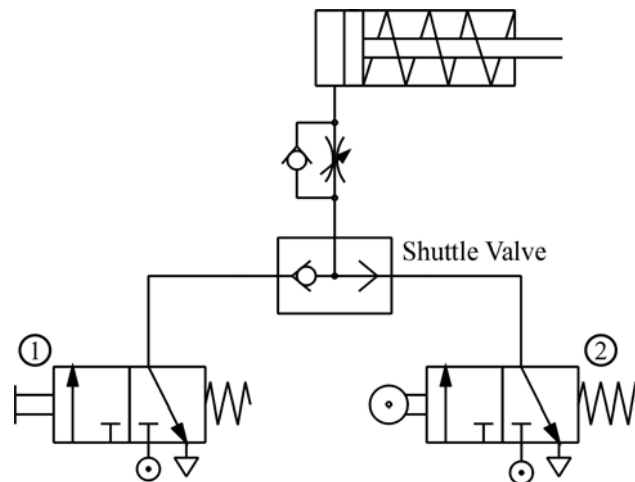


Fig. 29 Circuit diagram of an OR function circuit

(iii) AND Function

Another name for an AND function is interlock control. This means control is possible only when two conditions are satisfied. A classic example is a pneumatic system that works only when its safety door is closed and its manual control valve is operated. The flow passage will open only when both control valves are operated. Fig. 30 shows the circuit diagram of an AND function circuit. The cylinder will work only when both valve ① and ② are operated.

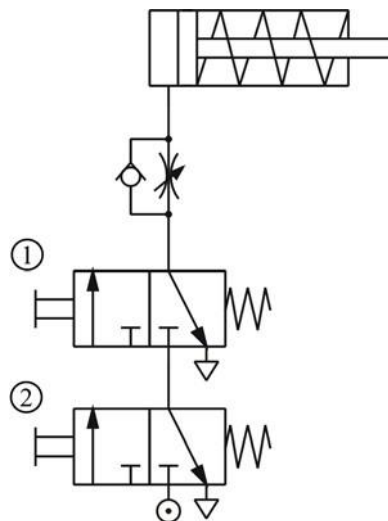


Fig. 30 Circuit diagram of an AND function circuit

(iv) NOT Function

Another name for a NOT function is inverse control. In order to hold or lock an operating conveyor or a similar machine, the cylinder must be locked until a signal for cancelling the lock is received. Therefore, the signal for cancelling the lock should be operated by a normally open type control valve. However, to cancel the lock, the same signal must also cancel the locks on other devices, like the indication signal ③ in Fig. 31. Fig. 31 shows how the normally closed type control valve ① can be used to cut off the normally open type control valve ② and achieve the goal of changing the signal.

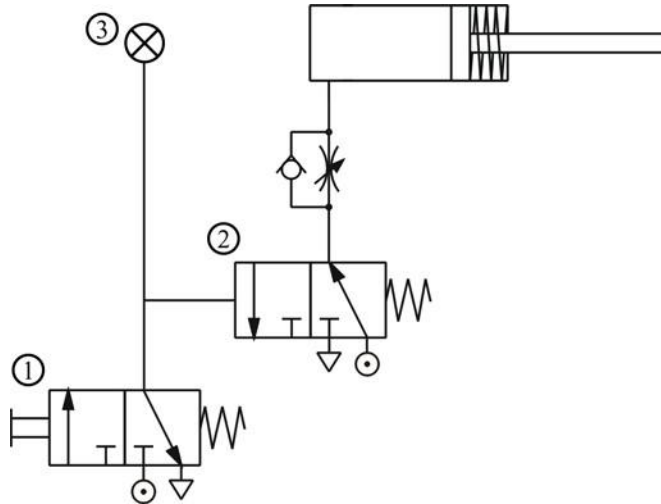


Fig. 31 Circuit diagram for a NOT function circuit

(f) Double acting cylinder

(i) Direct control

The only difference between a single acting cylinder and a double acting cylinder is that a double acting cylinder uses a 5/2 directional control valve instead of a 3/2 directional control valve (Fig. 32). Usually, when a double acting cylinder is not operated, outlet 'B' and inlet 'P' will be connected. In this circuit, whenever the operation button is pushed manually, the double acting cylinder will move back and forth once.

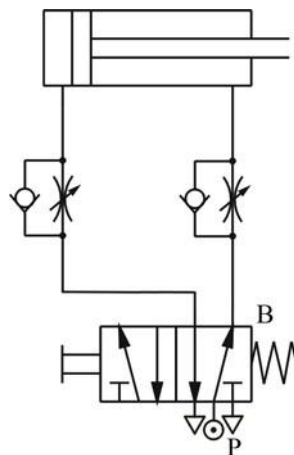


Fig. 32 Circuit diagram of a double acting cylinder direct control circuit

In order to control the speed in both directions, flow control valves are connected to the inlets on both sides of the cylinder. The direction of the flow control valve is opposite to that of the release of air by the flow control valve of the single acting cylinder. Compared to the throttle inlet, the flow control valve is tougher and more stable. Connecting the circuit in this way allows the input of sufficient air pressure and energy to drive the piston.

(ii) Single control

A cylinder always has to maintain its position in a lot of situations, even after the operational signal has disappeared. This can be achieved by the use of a circuit that possesses the memory function. As shown in Fig. 33, the extension path of a double acting cylinder is activated by control valve ①, while retraction is governed by control valve ②. Control valve ③, on the other hand, maintains the position of the cylinder by maintaining its own position. Control valve ③ will be changed only when one of the manual control valves is pushed. If both control valves ① and ② are operated at the same time, control valve ③ will be subject to the same pressure and will remain in its original position.

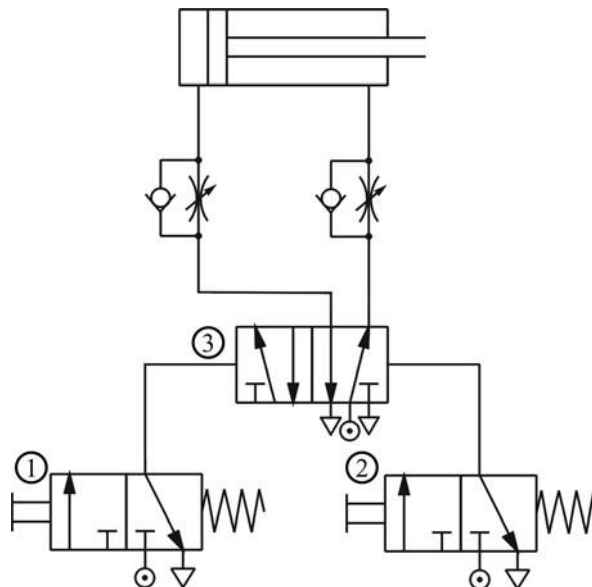


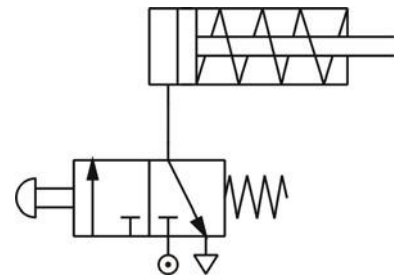
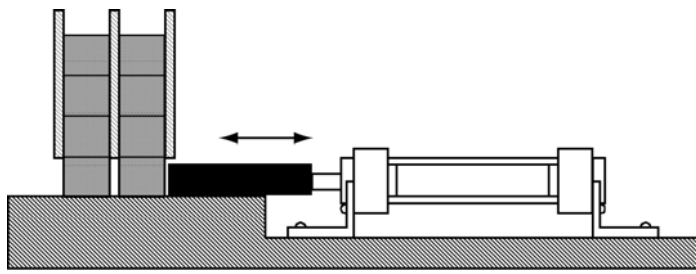
Fig. 33 Circuit that maintains the position of a double acting cylinder

6 The application of pneumatic systems

The application of pneumatic systems is very extensive. The following are some examples.

(a) Transport system

Fig. 34a shows a simplified industrial transport system. When the button switch is pushed, the cylinder will push one of the goods from the shelf onto the transfer belt. When the button switch is released, the cylinder will retract automatically. Fig. 34b shows the circuit diagram of the transport system.



(a) Operation of a pneumatic transport system

(b) Pneumatic circuit diagram of a pneumatic transport system

Fig. 34

(b) Vehicle door operation system

Pneumatic systems can be used to operate the doors of public vehicles (Fig. 35a). Assuming that the opening and closing of the doors are controlled by two button switches ON and OFF. When the button switch ON is pressed, the doors will open. When the button switch OFF is pushed, the doors will close. Fig. 35b shows a pneumatic system that can be used to operate the doors of vehicles.

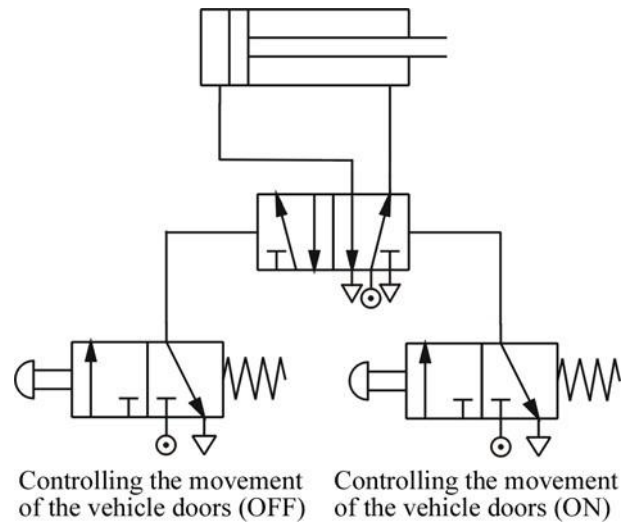
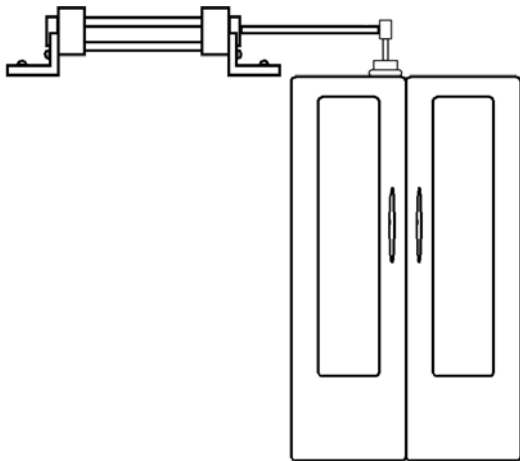


Fig. 35 (a) Operation of a pneumatic system that controls the movement of vehicle doors

(b) Pneumatic circuit diagram

7 Safety measures when using pneumatic control systems

- (a) Compressed air can cause serious damage to the human body if they enter the body through ducts like the oral cavity or ears.
- (b) Never spray compressed air onto anyone.
- (c) Under high temperature, compressed air can pass through human skin.
- (d) Compressed air released from the exhaust contains particles and oil droplets, which can cause damage to eyes.
- (e) Even though the pressure of compressed air in pipes and reservoirs is relatively low, when the container loses its entirety, fierce explosions may still occur.
- (f) Before switching on a compressed air supply unit, one should thoroughly inspect the whole circuit to see if there are any loose parts, abnormal pressure or damaged pipes.
- (g) A loose pipe may shake violently due to the high pressure built up inside it. Therefore, each time before the system pressure is increased, thorough inspection of the entire circuit is required to prevent accidents.
- (h) As the force produced by pneumatic cylinders is relatively large, and the action is usually very fast, you may suffer serious injuries if you get hit by a cylinder.
- (i) Switches should be installed on the compressed air supply unit to allow easy and speedy control of air flow.
- (j) In case of a leakage, the compressed air supply unit should be turned off immediately.
- (k) The compressed air supply unit must be turned off before changes can be made to the system.
- (l) Stay clear of the moving parts of the system. Never try to move the driving parts in the mechanical operation valve with your hand.

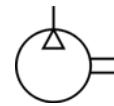
Appendix: Pneumatic components

There may exist differences in appearance and sizes of pneumatic components produced by different manufacturers. However, the functions and operating methods among these components are similar. The following are the pictures and cross section diagrams of the pneumatic components made by another manufacturer for your reference.

1. Pneumatic components for the production and transportation of compressed air
 - (a) Compressor



Fig. 36 (a) Compressor



(b) Pneumatic symbol

- (b) Pressure regulating component

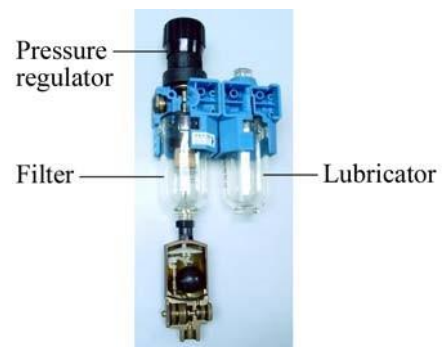
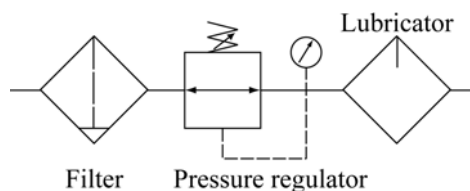


Fig. 37 (a) Pressure regulating component (b) Cross section of pressure regulating component



(c) Pneumatic symbol

2. Pneumatic components for consumption of compressed air

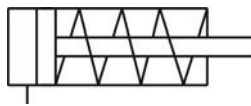
(a) Single acting cylinder



Fig. 38 (a) Single acting cylinder



(b) Cross section of a single acting cylinder



(c) Pneumatic symbol

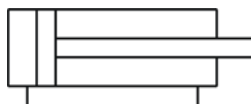
(b) Double acting cylinder



Fig. 39 (a) Double acting cylinder



(b) Cross section of a double acting cylinder



(c) Pneumatic symbol

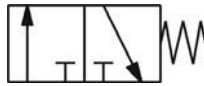
(c) 3/2 Directional control valve



Fig. 40 (a) 3/2 Directional control valve



(b) Cross section of a 3/2 directional control valve



(c) Pneumatic symbols

(a) Normally closed type

(b) Normally open type

(d) 5/2 Directional control valve

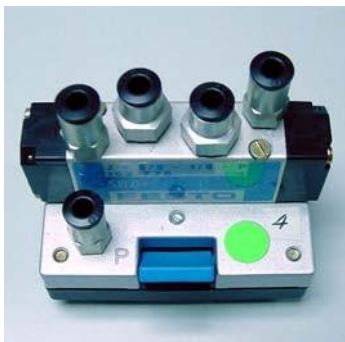
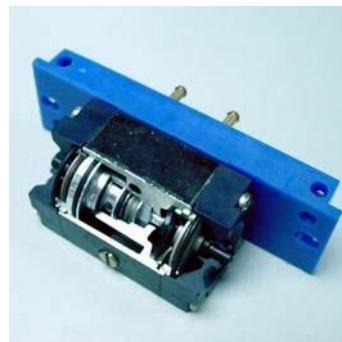


Fig. 41 (a) 5/2 Directional control valve



(b) Cross section



(c) Pneumatic symbol

(e) Flow control valve

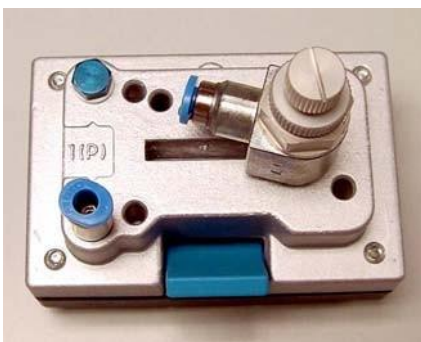
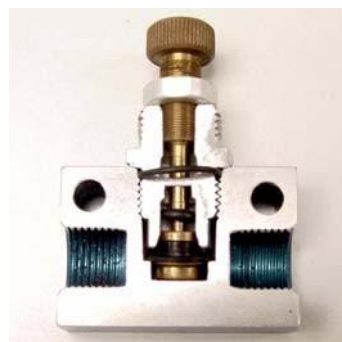
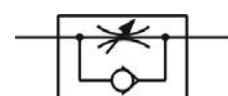


Fig. 42 (a) Flow control valve



(b) Cross section



(c) Pneumatic symbol

(f) Shuttle valve

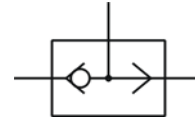
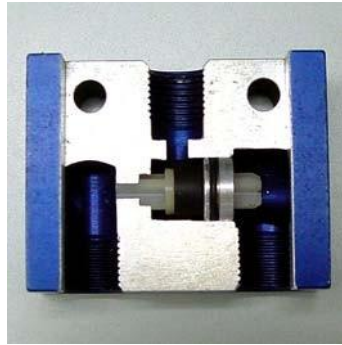


Fig. 43 (a) Shuttle valve

(b) Cross section

(c) Pneumatic symbol

3. Other component

(a) Connecting pipe



Fig. 44 Connecting pipes

Hydraulic Systems

Introduction

1. Introduction

The controlled movement of parts or a controlled application of force is a common requirement in the industries. These operations are performed mainly by using electrical machines or diesel, petrol and steam engines as a prime mover. These prime movers can provide various movements to the objects by using some mechanical attachments like screw jack, lever, rack and pinions etc. However, these are not the only prime movers. The enclosed fluids (liquids and gases) can also be used as prime movers to provide controlled motion and force to the objects or substances. The specially designed enclosed fluid systems can provide both linear as well as rotary motion. The high magnitude controlled force can also be applied by using these systems. This kind of enclosed fluid based systems using pressurized incompressible liquids as transmission media are called as hydraulic systems. The hydraulic system works on the principle of Pascal's law which says that the pressure in an enclosed fluid is uniform in all the directions. The Pascal's law is illustrated in figure 5.1.1. The force given by fluid is given by the multiplication of pressure and area of cross section. As the pressure is same in all the direction, the smaller piston feels a smaller force and a large piston feels a large force. Therefore, a large force can be generated with smaller force input by using hydraulic systems.

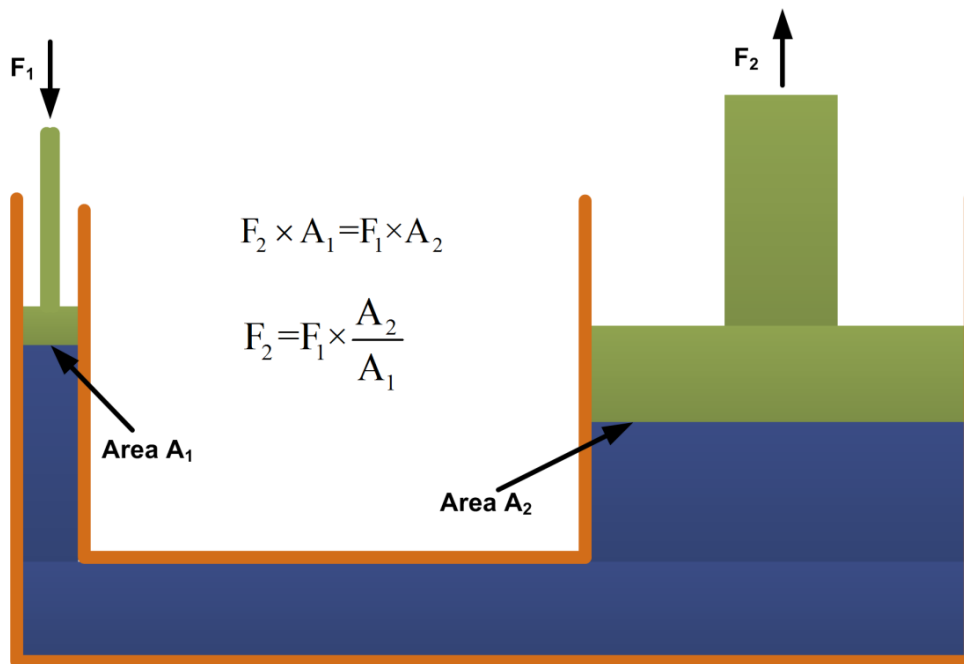


Figure 5.1.1 Principle of hydraulic system

The hydraulic systems consists a number of parts for its proper functioning. These include storage tank, filter, hydraulic pump, pressure regulator, control valve, hydraulic cylinder, piston and leak proof fluid flow pipelines. The schematic of a simple hydraulic system is shown in figure 5.1.2. It consists of:

- a movable piston connected to the output shaft in an enclosed cylinder
- storage tank
- filter
- electric pump
- pressure regulator
- control valve
- leak proof closed loop piping.

The output shaft transfers the motion or force however all other parts help to control the system. The storage/fluid tank is a reservoir for the liquid used as a transmission media. The liquid used is generally high density incompressible oil. It is filtered to remove dust or any other unwanted particles and then pumped by the hydraulic pump. The capacity of pump depends on the hydraulic system design. These pumps generally deliver constant volume in each revolution of the pump shaft. Therefore, the fluid pressure can increase indefinitely at the dead end of the piston until the system fails. The pressure regulator is used to avoid such circumstances which redirect the excess fluid back to the storage tank. The movement of piston is controlled by changing liquid flow from port A and port B. The cylinder movement is controlled by using control valve which directs the fluid flow. The fluid pressure line is connected to the port B to raise the piston and it is connected to port A to lower down the piston. The valve can also stop the fluid flow in any of the port. The leak proof piping is also important due to safety, environmental hazards and economical aspects. Some accessories such as flow control system, travel limit control, electric motor starter and overload protection may also be used in the hydraulic systems which are not shown in figure 5.1.2.

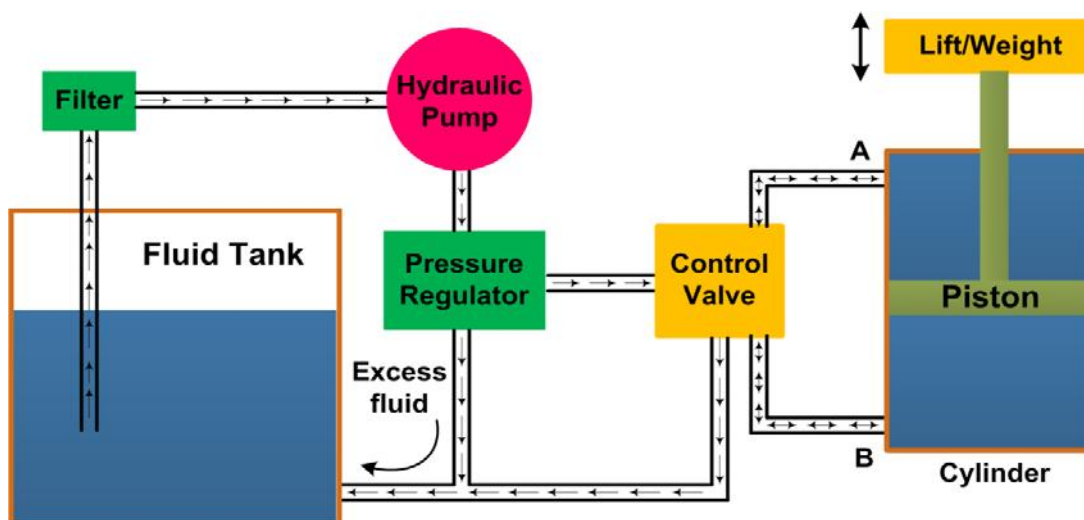


Figure 5.1.2 Schematic of hydraulic system

2. Applications of hydraulic systems

The hydraulic systems are mainly used for precise control of larger forces. The main applications of hydraulic system can be classified in five categories:

Industrial: Plastic processing machineries, steel making and primary metal extraction applications, automated production lines, machine tool industries, paper industries, loaders, crushes, textile machineries, R & D equipment and robotic systems etc.

Mobile hydraulics: Tractors, irrigation system, earthmoving equipment, material handling equipment, commercial vehicles, tunnel boring equipment, rail equipment, building and construction machineries and drilling rigs etc.

Automobiles: It is used in the systems like breaks, shock absorbers, steering system, wind shield, lift and cleaning etc.

Marine applications: It mostly covers ocean going vessels, fishing boats and navel equipment.

Aerospace equipment: There are equipment and systems used for rudder control, landing gear, breaks, flight control and transmission etc. which are used in airplanes, rockets and spaceships.

3. Hydraulic Pump

The combined pumping and driving motor unit is known as hydraulic pump. The hydraulic pump takes hydraulic fluid (mostly some oil) from the storage tank and delivers it to the rest of the hydraulic circuit. In general, the speed of pump is constant and the pump delivers an equal volume of oil in each revolution. The amount and direction of fluid flow is controlled by some external mechanisms. In some cases, the hydraulic pump itself is operated by a servo controlled motor but it makes the system complex. The hydraulic pumps are characterized by its flow rate capacity, power consumption, drive speed, pressure delivered at the outlet and efficiency of the pump. The pumps are not 100% efficient. The efficiency of a pump can be specified by two ways. One is the volumetric efficiency which is the ratio of actual volume of fluid delivered to the maximum theoretical volume possible. Second is power efficiency which is the ratio of output hydraulic power to the input mechanical/electrical power. The typical efficiency of pumps varies from 90-98%.

The hydraulic pumps can be of two types:

- centrifugal pump
- reciprocating pump

Centrifugal pump uses rotational kinetic energy to deliver the fluid. The rotational energy typically comes from an engine or electric motor. The fluid enters the pump impeller along or near to the rotating axis, accelerates in the propeller and flung out to the periphery by centrifugal force as shown in figure 5.1.3. In centrifugal pump the delivery is not constant and varies according to the outlet pressure. These pumps are not suitable for high pressure applications and are generally used for low-pressure and high-volume flow applications. The maximum pressure capacity is limited to 20-30 bars and the specific speed ranges from 500 to 10000. Most of the centrifugal pumps are not self-priming and the pump casing needs to be filled with liquid before the pump is started.

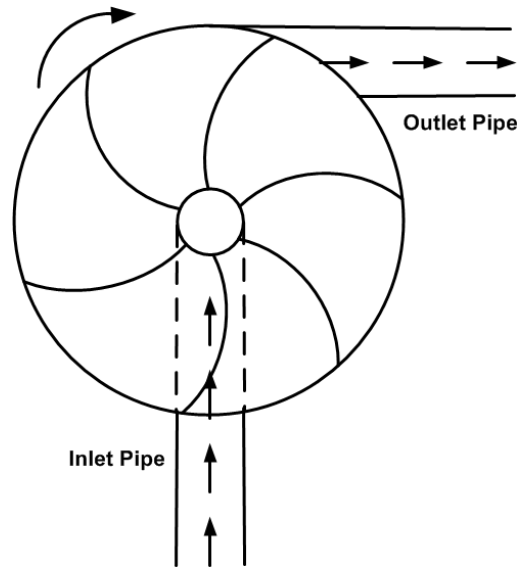


Figure 5.1.3 Centrifugal pump

The reciprocating pump is a positive plunger pump. It is also known as positive displacement pump or piston pump. It is often used where relatively small quantity is to be handled and the delivery pressure is quite large. The construction of these pumps is similar to the four stroke engine as shown in figure 5.1.4. The crank is driven by some external rotating motor. The piston of pump reciprocates due to crank rotation. The piston moves down in one half of crank rotation, the inlet valve opens and fluid enters into the cylinder. In second half crank rotation the piston moves up, the outlet valve opens and the fluid moves out from the outlet. At a time, only one valve is opened and another is closed so there is no fluid leakage. Depending on the area of cylinder the pump delivers constant volume of fluid in each cycle independent to the pressure at the output port.

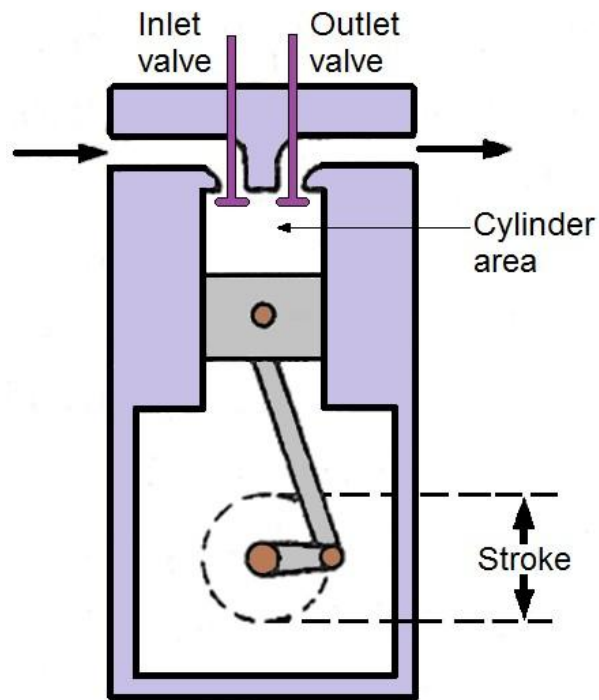


Figure 5.1.4 Reciprocating or positive displacement pump

4. Pump Lift

In general, the pump is placed over the fluid storage tank as shown in figure 5.1.5. The pump creates a negative pressure at the inlet which causes fluid to be pushed up in the inlet pipe by atmospheric pressure. It results in the fluid lift in the pump suction. The maximum pump lift can be determined by atmospheric pressure and is given by pressure head as given below:

$$\text{Pressure Head, } P = \rho gh \quad (5.1.1)$$

Theoretically, a pump lift of 8 m is possible but it is always lesser due to undesirable effects such as cavitation. The cavitation is the formation of vapor cavities in a liquid. The cavities can be small liquid-free zones ("bubbles" or "voids") formed due to partial vaporization of fluid (liquid). These are usually generated when a liquid is subjected to rapid changes of pressure and the pressure is relatively low. At higher pressure, the voids implode and can generate an intense shockwave. Therefore, the cavitation should always be avoided. The cavitation can be reduced by maintaining lower flow velocity at the inlet and therefore the inlet pipes have larger diameter than the outlet pipes in a pump. The pump lift should be as small as possible to decrease the cavitation and to increase the efficiency of the pump.

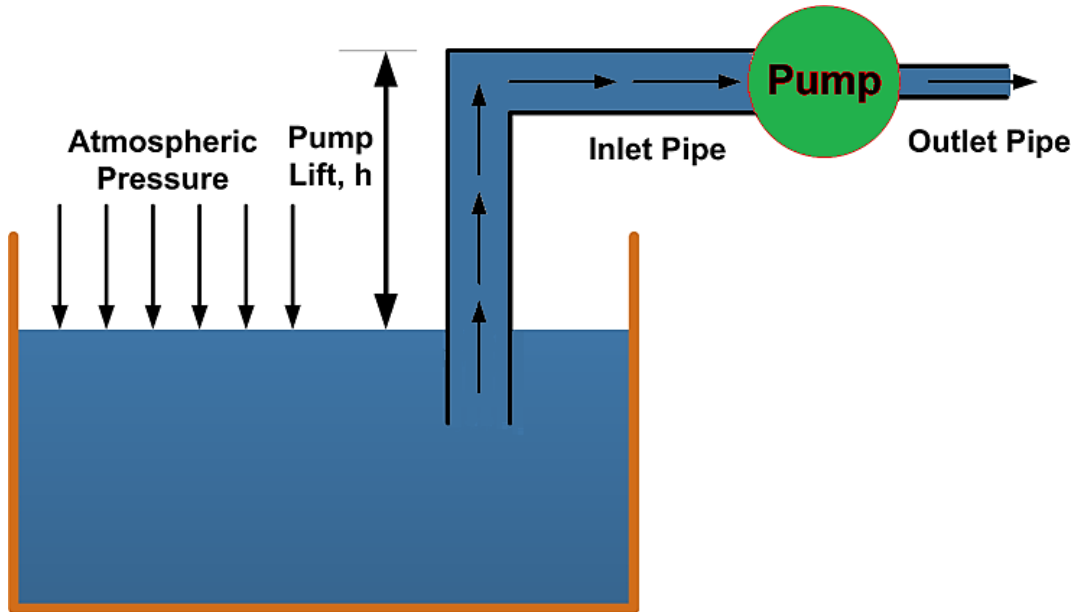


Figure 5.1.5 Pump lift

5. Pressure Regulation

The pressure regulation is the process of reduction of high source pressure to a lower working pressure suitable for the application. It is an attempt to maintain the outlet pressure within acceptable limits. The pressure regulation is performed by using pressure regulator. The primary function of a pressure regulator is to match the fluid flow with demand. At the same time, the regulator must maintain the outlet pressure within certain acceptable limits.

The schematic of pressure regulator and various valves placement is shown in figure 5.1.6. When the valve V_1 is closed and V_2 is opened then the load moves down and fluid returns to the tank but the pump is dead ended and it leads to a continuous increase in pressure at pump delivery. Finally, it may lead to permanent failure of the pump. Therefore some method is needed to keep the delivery pressure P_1 within the safe level. It can be achieved by placing pressure regulating valve V_3 as shown in figure 5.1.6. This valve is closed in normal conditions and when the pressure exceeds a certain limit, it opens and fluid from pump outlet returns to the tank via pressure regulating valve V_3 . As the pressure falls in a limiting range, the valve V_3 closes again.

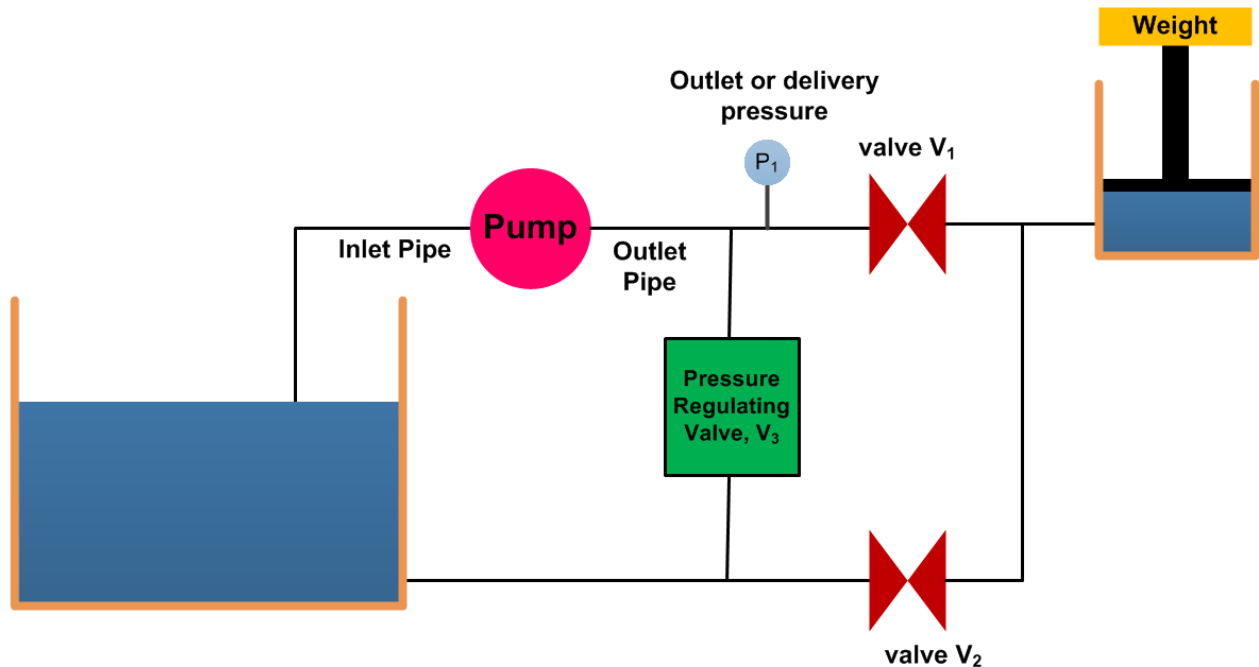


Figure 5.1.6 Schematic of pressure regulation

When valve V_1 is closed, the whole fluid is dumped back to the tank through the pressure regulating valve. This leads to the substantial loss of power because the fluid is circulating from tank to pump and then pump to tank without performing any useful work. This may lead to increase in fluid temperature because the energy input into fluid leads to the increase in fluid temperature. This may need to the installation of heat exchanger in to the storage tank to extract the excess heat. Interestingly, the motor power

consumption is more in such condition because the outlet pressure is higher than the working pressure.

6. Advantages and Disadvantages of Hydraulic system

Advantages

- The hydraulic system uses incompressible fluid which results in higher efficiency.
- It delivers consistent power output which is difficult in pneumatic or mechanical drive systems.
- Hydraulic systems employ high density incompressible fluid. Possibility of leakage is less in hydraulic system as compared to that in pneumatic system. The maintenance cost is less.
- These systems perform well in hot environment conditions.

Disadvantages

- The material of storage tank, piping, cylinder and piston can be corroded with the hydraulic fluid. Therefore one must be careful while selecting materials and hydraulic fluid.
- The structural weight and size of the system is more which makes it unsuitable for the smaller instruments.
- The small impurities in the hydraulic fluid can permanently damage the complete system, therefore one should be careful and suitable filter must be installed.
- The leakage of hydraulic fluid is also a critical issue and suitable prevention method and seals must be adopted.
- The hydraulic fluids, if not disposed properly, can be harmful to the environment.

Hydraulic Pumps

1. Classification of Hydraulic Pumps

These are mainly classified into two categories:

- A. Non-positive displacement pumps
- B. Positive displacement pumps.

A. Non-Positive Displacement Pumps

These pumps are also known as hydro-dynamic pumps. In these pumps the fluid is pressurized by the rotation of the propeller and the fluid pressure is proportional to the rotor speed. These pumps can not withstanding high pressures and generally used for low-pressure and high-volume flow applications. The fluid pressure and flow generated due to inertia effect of the fluid. The fluid motion is generated due to rotating propeller. These pumps provide a smooth and continuous flow but the flow output decreases with increase in system resistance (load). The flow output decreases because some of the fluid slip back at higher resistance. The fluid flow is completely stopped at very large system resistance and thus the volumetric efficiency will become zero. Therefore, the flow rate not only depends on the rotational speed but also on the resistance provided by the system. The important advantages of non-positive displacement pumps are lower initial cost, less operating maintenance because of less moving parts, simplicity of operation, higher reliability and suitability with wide range of fluid etc. These pumps are primarily used for transporting fluids and find little use in the hydraulic or fluid power industries. Centrifugal pump is the common example of non-positive displacement pumps. Details have already discussed in the previous lecture.

B. Positive displacement pump

These pumps deliver a constant volume of fluid in a cycle. The discharge quantity per revolution is fixed in these pumps and they produce fluid flow proportional to their displacement and rotor speed. These pumps are used in most of the industrial fluid power applications. The output fluid flow is constant and is independent of the system pressure (load). The important advantage associated with these pumps is that the high-pressure and low-pressure areas (means input and output region) are separated and hence the fluid cannot leak back due to higher pressure at the outlets. These features make the positive displacement pump most suited and universally accepted for hydraulic systems. The important advantages of positive displacement pumps over non-positive displacement pumps include capability to generate high pressures, high volumetric efficiency, high

power to weight ratio, change in efficiency throughout the pressure range is small and wider operating range pressure and speed. The fluid flow rate of these pumps ranges from 0.1 and 15,000 gpm, the pressure head ranges between 10 and 100,000 psi and specific speed is less than 500.

It is important to note that the positive displacement pumps do not produce pressure but they only produce fluid flow. The resistance to output fluid flow generates the pressure. It means that if the discharge port (output) of a positive displacement pump is opened to the atmosphere, then fluid flow will not generate any output pressure above atmospheric pressure. But, if the discharge port is partially blocked, then the pressure will rise due to the increase in fluid flow resistance. If the discharge port of the pump is completely blocked, then an infinite resistance will be generated. This will result in the breakage of the weakest component in the circuit. Therefore, the safety valves are provided in the hydraulic circuits along with positive displacement pumps. Important positive displacement pumps are gears pumps, vane pumps and piston pumps. The details of these pumps are discussed in the following sections.

2. Gear Pumps

Gear pump is a robust and simple positive displacement pump. It has two meshed gears revolving about their respective axes. These gears are the only moving parts in the pump. They are compact, relatively inexpensive and have few moving parts. The rigid design of the gears and houses allow for very high pressures and the ability to pump highly viscous fluids. They are suitable for a wide range of fluids and offer self-priming performance. Sometimes gear pumps are designed to function as either a motor or a pump. These pump includes helical and herringbone gear sets (instead of spur gears), lobe shaped rotors similar to Roots blowers (commonly used as superchargers), and mechanical designs that allow the stacking of pumps. Based upon the design, the gear pumps are classified as:

- External gear pumps
- Lobe pumps
- Internal gear pumps
- Gerotor pumps

Generally gear pumps are used to pump:

- Petrochemicals: Pure or filled bitumen, pitch, diesel oil, crude oil, lube oil etc.
- Chemicals: Sodium silicate, acids, plastics, mixed chemicals, isocyanates etc.
- Paint and ink
- Resins and adhesives
- Pulp and paper: acid, soap, lye, black liquor, kaolin, lime, latex, sludge etc.
- Food: Chocolate, cacao butter, fillers, sugar, vegetable fats and oils, molasses, animal food etc.

External gear pump

The external gear pump consists of externally meshed two gears housed in a pump case as shown in figure 5.2.1. One of the gears is coupled with a prime mover and is called as driving gear and another is called as driven gear. The rotating gear carries the fluid from the tank to the outlet pipe. The suction side is towards the portion where the gear teeth come out of the mesh. When the gears rotate, volume of the chamber expands leading to pressure drop below atmospheric value. Therefore the vacuum is created and the fluid is pushed into the void due to atmospheric pressure. The fluid is trapped between housing and rotating teeth of the gears. The discharge side of pump is towards the portion where the gear teeth run into the mesh and the volume decreases between meshing teeth. The pump has a positive internal seal against leakage; therefore, the fluid is forced into the outlet port. The gear pumps are often equipped with the side wear plate to avoid the leakage. The clearance between gear teeth and housing and between side plate and gear face is very important and plays an important role in preventing leakage. In general, the gap distance is less than 10 micrometers. The amount of fluid discharge is determined by the number of gear teeth, the volume of fluid between each pair of teeth and the speed of rotation. The important drawback of external gear pump is the unbalanced side load on its bearings. It is caused due to high pressure at the outlet and low pressure at the inlet which results in slower speeds and lower pressure ratings in addition to reducing the bearing life. Gear pumps are most commonly used for the hydraulic fluid power applications and are widely used in chemical installations to pump fluid with a certain viscosity.

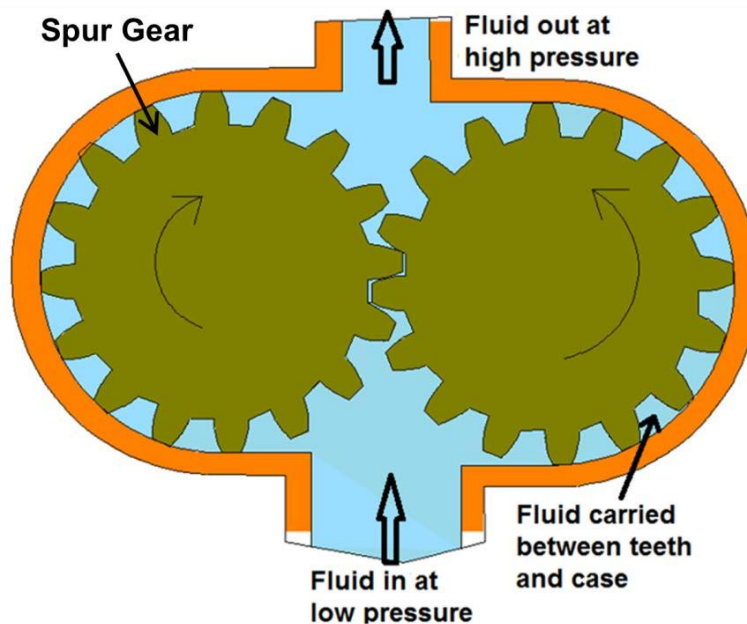


Figure 5.2.1 Gear pump

Lobe Pump

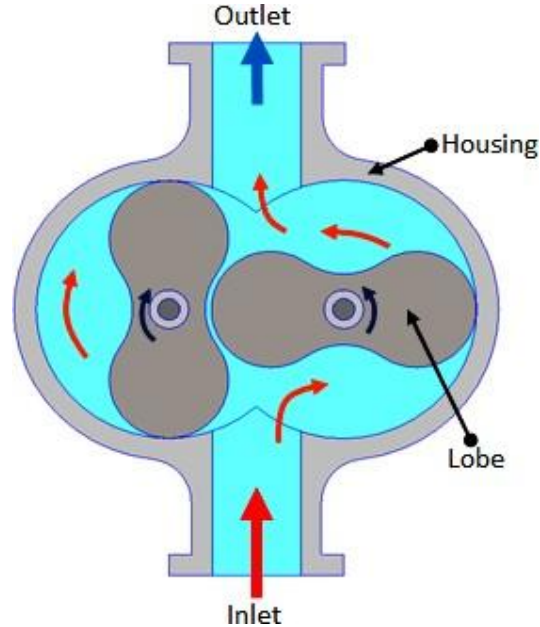


Figure 5.2.3 Lobe pump

Lobe pumps work on the similar principle of working as that of external gear pumps. However in Lobe pumps, the lobes do not make any contact like external gear pump (see Figure 5.2.3). Lobe contact is prevented by external timing gears located in the gearbox. Similar to the external gear pump, the lobes rotate to create expanding volume at the inlet. Now, the fluid flows into the cavity and is trapped by the lobes. Fluid travels around the interior of casing in the pockets between the lobes and the casing. Finally, the meshing of the lobes forces liquid to pass through the outlet port. The bearings are placed out of the pumped liquid. Therefore the pressure is limited by the bearing location and shaft deflection.

Because of superb sanitary qualities, high efficiency, reliability, corrosion resistance and good clean-in-place and steam-in-place (CIP/SIP) characteristics, Lobe pumps are widely used in industries such as pulp and paper, chemical, food, beverage, pharmaceutical and biotechnology etc. These pumps can handle solids (e.g., cherries and olives), slurries, pastes, and a variety of liquids. A gentle pumping action minimizes product degradation. They also offer continuous and intermittent reversible flows. Flow is relatively independent of changes in process pressure and therefore, the output is constant and continuous.

Lobe pumps are frequently used in food applications because they handle solids without damaging the product. Large sized particles can be pumped much effectively than in other positive displacement types. As the lobes do not make any direct contact therefore, the clearance is not as close as in other Positive displacement pumps. This specific design of pump makes it suitable to handle low viscosity fluids with diminished performance.

Loading characteristics are not as good as other designs, and suction ability is low. High-viscosity liquids require reduced speeds to achieve satisfactory performance. The reduction in speed can be 25% or more in case of high viscosity fluid.

Internal Gear Pump

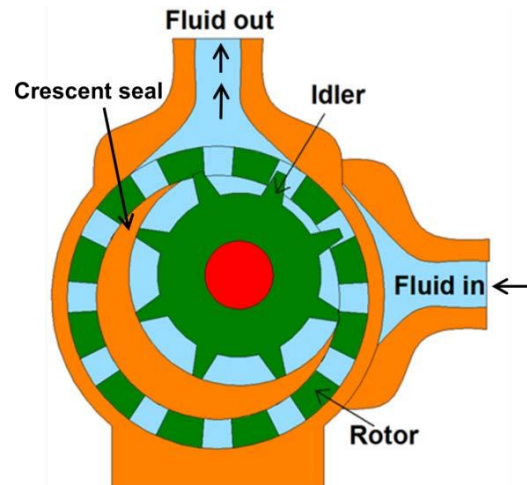


Figure 5.2.4 Internal gear pump

Internal gear pumps are exceptionally versatile. They are often used for low or medium viscosity fluids such as solvents and fuel oil and wide range of temperature. This is non-pulsing, self-priming and can run dry for short periods. It is a variation of the basic gear pump.

It comprises of an internal gear, a regular spur gear, a crescent-shaped seal and an external housing. The schematic of internal gear pump is shown in figure 5.2.4. Liquid enters the suction port between the rotor (large exterior gear) and idler (small interior gear) teeth. Liquid travels through the pump between the teeth and crescent. Crescent divides the liquid and acts as a seal between the suction and discharge ports. When the teeth mesh on the side opposite to the crescent seal, the fluid is forced out through the discharge port of the pump. This clearance between gears can be adjusted to accommodate high temperature, to handle high viscosity fluids and to accommodate the wear. These pumps are bi-rotational so that they can be used to load and unload the vessels. As these pumps have only two moving parts and one stuffing box, therefore they are reliable, simple to operate and easy to maintain. However, these pumps are not suitable for high speed and high pressure applications. Only one bearing is used in the pump therefore overhung load on shaft bearing reduces the life of the bearing.

Applications

Some common internal gear pump applications are:

- All varieties of fuel oil and lube oil
- Resins and Polymers
- Alcohols and solvents
- Asphalt, Bitumen, and Tar
- Polyurethane foam (Isocyanate and polyol)
- Food products such as corn syrup, chocolate, and peanut butter
- Paint, inks, and pigments
- Soaps and surfactants
- Glycol

Gerotor Pump

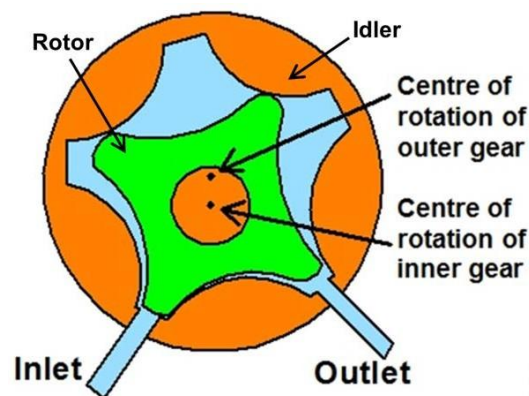


Figure 5.2.5 Gerotor pump

Gerotor is a positive displacement pump. The name Gerotor is derived from "Generated Rotor". At the most basic level, a Gerotor is essentially one that is moved via fluid power. Originally this fluid was water, today the wider use is in hydraulic devices. The schematic of Gerotor pump is shown in figure 5.2.5. Gerotor pump is an internal gear pump without the crescent. It consists of two rotors viz. inner and outer rotor. The inner rotor has N teeth, and the outer rotor has $N+1$ teeth. The inner rotor is located off-center and both rotors rotate. The geometry of the two rotors partitions the volume between them into N different dynamically-changing volumes. During the rotation, volume of each partition changes continuously. Therefore, any given volume first increases, and then decreases. An increase in volume creates vacuum. This vacuum creates suction, and thus, this part of the cycle sucks the fluid. As the volume decreases, compression occurs. During this compression period, fluids can be pumped, or compressed (if they are gaseous fluids).

The close tolerance between the gears acts as a seal between the suction and discharge ports. Rotor and idler teeth mesh completely to form a seal equidistant from the discharge and suction ports. This seal forces the liquid out of the discharge port. The flow output is uniform and constant at the outlets.

The important advantages of the pumps are high speed operation, constant discharge in all pressure conditions, bidirectional operation, less sound in running condition and less maintenance due to only two moving parts and one stuffing box etc. However, the pump is having some limitations such as medium pressure operating range, clearance is fixed, solids can't be pumped and overhung load on the shaft bearing etc.

Applications

Gerotors are widely used in industries and are produced in variety of shapes and sizes by a number of different methods. These pumps are primarily suitable for low pressure applications such as lubrication systems or hot oil filtration systems, but can also be found in low to moderate pressure hydraulic applications. However common applications are as follows:

- Light fuel oils
- Lube oil
- Cooking oils
- Hydraulic fluid

Hydraulic Pumps -2

1. Vane Pumps

In the previous lecture we have studied the gear pumps. These pumps have a disadvantage of small leakage due to gap between gear teeth and the pump housing. This limitation is overcome in vane pumps. The leakage is reduced by using spring or hydraulically loaded vanes placed in the slots of driven rotor. Capacity and pressure ratings of a vane pump are generally lower than the gear pumps, but reduced leakage gives an improved volumetric efficiency of around 95%.

Vane pumps are available in a number of vane configurations including sliding vane, flexible vane, swinging vane, rolling vane, and external vane etc. Each type of vane pump has its own advantages. For example, external vane pumps can handle large solids. Flexible vane pumps can handle only the small solids but create good vacuum. Sliding vane pumps can run dry for short periods of time and can handle small amounts of vapor. The vane pumps are known for their dry priming, ease of maintenance, and good suction characteristics. The operating range of these pumps varies from $-32\text{ }^{\circ}\text{C}$ to $260\text{ }^{\circ}\text{C}$.

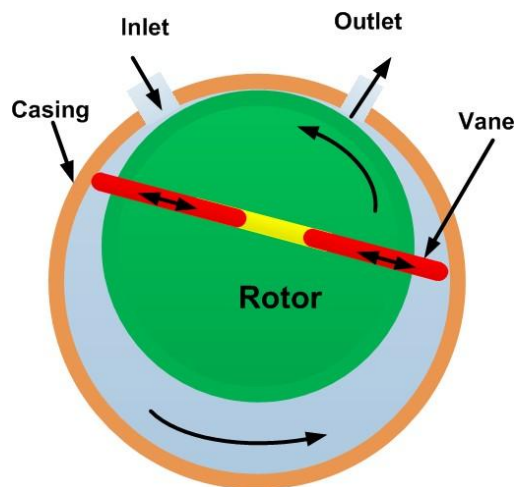


Figure 5.3.1 Schematic of working principle of vane pump

The schematic of vane pump working principle is shown in figure 5.3.1. Vane pumps generate a pumping action by tracking of vanes along the casing wall. The vane pumps generally consist of a rotor, vanes, ring and a port plate with inlet and outlet ports. The rotor in a vane pump is connected to the prime mover through a shaft. The vanes are

located on the slotted rotor. The rotor is eccentrically placed inside a cam ring as shown in the figure. The rotor is sealed into the cam by two side plates. When the prime mover rotates the rotor, the vanes are thrown outward due to centrifugal force. The vanes track along the ring. It provides a tight hydraulic seal to the fluid which is more at the higher rotation speed due to higher centrifugal force. This produces a suction cavity in the ring as the rotor rotates. It creates vacuum at the inlet and therefore, the fluid is pushed into the pump through the inlet. The fluid is carried around to the outlet by the vanes whose retraction causes the fluid to be expelled. The capacity of the pump depends upon the eccentricity, expansion of vanes, width of vanes and speed of the rotor. It can be noted that the fluid flow will not occur when the eccentricity is zero. These pumps can handle thin liquids (low viscosity) at relatively higher pressure. These pumps can be run dry for a small duration without any failure. These pumps develop good vacuum due to negligible leakage. However, these pumps are not suitable for high speed applications and for the high viscosity fluids or fluids carrying some abrasive particles. The maintenance cost is also higher due to many moving parts. These pumps have various applications for the pumping of following fluids:

- Aerosol and Propellants
- Aviation Service - Fuel Transfer, Deicing
- Auto Industry - Fuels, Lubes, Refrigeration Coolants
- Bulk Transfer of LPG and NH₃
- LPG Cylinder Filling
- Alcohols
- Refrigeration - Freons, Ammonia
- Solvents
- Aqueous solutions

Unbalanced Vane pump

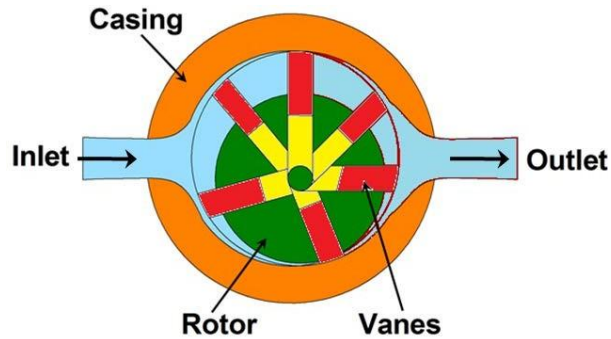


Figure 5.3.2 Unbalanced vane pump

In practice, the vane pumps have more than one vane as shown in figure 5.3.2. The rotor is offset within the housing, and the vanes are constrained by a cam ring as they cross inlet and outlet ports. Although the vane tips are held against the housing, still a small amount of leakage exists between rotor faces and body sides. Also, the vanes compensate to a large degree for wear at the vane tips or in the housing itself. The pressure difference between outlet and inlet ports creates a large amount of load on the vanes and a significant amount of side load on the rotor shaft which can lead to bearing failure. This type of pump is called as unbalanced vane pump.

Balanced vane pump

Figure 5.3.3 shows the schematic of a balanced vane pump. This pump has an elliptical cam ring with two inlet and two outlet ports. Pressure loading still occurs in the vanes but the two identical pump halves create equal but opposite forces on the rotor. It leads to the zero net force on the shaft and bearings. Thus, lives of pump and bearing increase significantly. Also the sounds and vibrations decrease in the running mode of the pump.

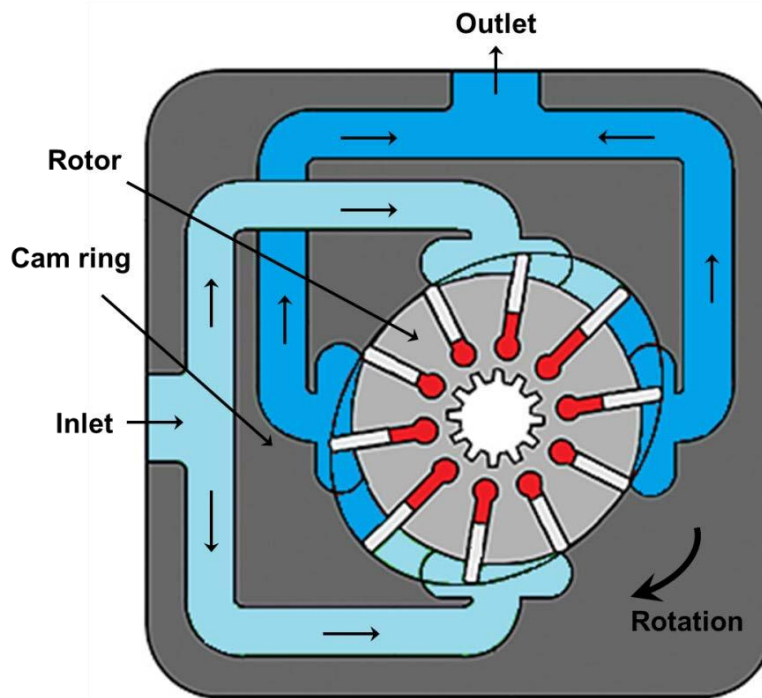


Figure 5.3.3 Balanced Vane Pump

Adjustable vane pump

The proper design of pump is important and a challenging task. In ideal condition, the capacity of a pump should be exactly same to load requirements. A pump with larger capacity wastes energy as the excess fluid will pass through the pressure relief valve. It also leads to a rise in fluid temperature due to energy conversion to the heat instead of useful work and therefore it needs some external cooling arrangement. Therefore, the higher capacity pump increases the power consumption and makes the system bulky and costly. Pumps are generally available with certain standard capacities and the user has to choose the next available capacity of the pump. Also, the flow rate from the pump in most hydraulic applications needs to be varying as per the requirements. Therefore, some vane pumps are also available with adjustable capacity as shown in figure 5.3.4. This can be achieved by adjusting a positional relationship between rotor and the inner casing by the help of an external controlling screw. These pumps basically consist of a rotor, vanes, cam ring, port plate, thrust bearing for guiding the cam ring and a discharge control screw by which the position of the cam ring relative to the rotor can be varied. In general, the adjustable vane pumps are unbalanced pump type.

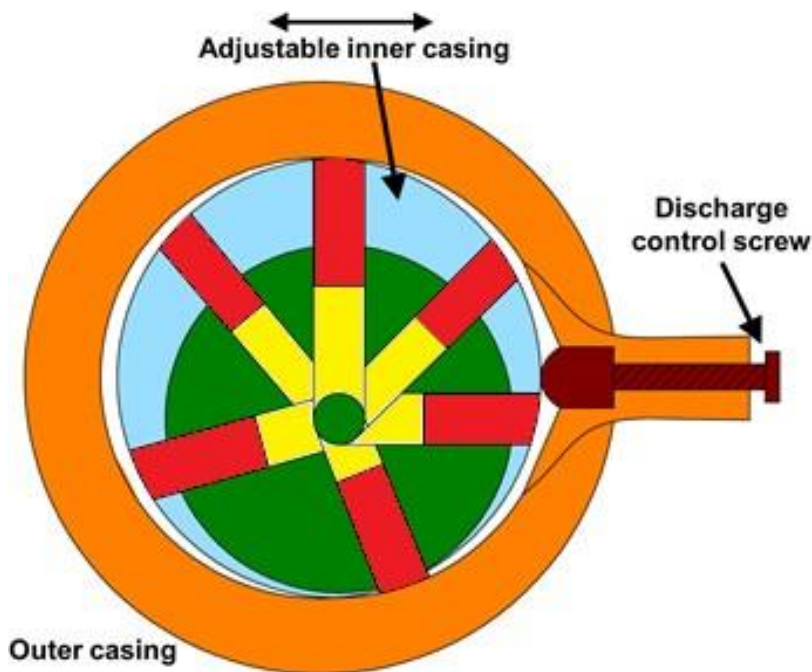


Figure 5.3.4 Adjustable vane pump

The amount of fluid that is displaced by a vane pump running at a constant speed is determined by the maximum extension of the vanes and the vanes width. However, for a pump running in operation, the width of vanes cannot be changed but the distance by which the vanes are extended can be varied. This is possible by making a provision for changing the position of the cam ring (adjustable inner casing) relative to the rotor as shown in figure 5.3.4. The eccentricity of rotor with respect to the cam ring is adjusted by

the movement of the screw. The delivery volume increases with increase in the eccentricity. This kind of arrangement can be used to achieve a variable volume from the pump and is known as variable displacement vane pump.

In general, the adjusted vane pumps are pressure compensated. It means that the discharge is controlled by pre-adjusted value and when the discharge pressure reaches a certain (adjusted) value; the pumping action ceases. This mechanism is accomplished by using a compensating spring to offset the cam ring. Initially, the eccentricity is maximum because the discharge pressure is zero and spring force keeps the cam ring at the extreme right position. As the discharge pressure increases, it acts on the inner contour of the cam ring. It pushes the cam ring towards the left against the spring force and hence the eccentricity reduces and hence the discharge through the pump reduces. When the discharge pressure becomes high enough to overcome the entire spring force; the compensator spring will compress until the zero eccentricity is achieved. In this condition, the pumping action ceases and the fluid flow (except small leakages) does not occur. Therefore, the system pressure can be adjusted by setting the compensator spring. These pumps ensure their own protection against excessive system pressure and do not rely on the safety control devices of the hydraulic system. These pumps are used as energy savings devices and have been used in many applications, including automotive transmissions.

2. Piston pumps

Piston pumps are meant for the high-pressure applications. These pumps have high-efficiency and simple design and needs lower maintenance. These pumps convert the rotary motion of the input shaft to the reciprocating motion of the piston. These pumps work similar to the four stroke engines. They work on the principle that a reciprocating piston draws fluid inside the cylinder when the piston retracts in a cylinder bore and discharge the fluid when it extends. Generally, these pumps have fixed inclined plate or variable degree of angle plate known as swash plate (shown in Figure 5.3.5 and Figure 5.3.6). When the piston barrel assembly rotates, the swash plate in contact with the piston slippers slides along its surface. The stroke length (axial displacement) depends on the inclination angle of the swash plate. When the swash plate is vertical, the reciprocating motion does not occur and hence pumping of the fluid does not take place. As the swash plate angle increases, the piston reciprocates inside the cylinder barrel. The stroke length increases with increase in the swash plate angle and therefore volume of pumping fluid increases. During one half of the rotation cycle, the pistons move out of the cylinder barrel and the volume of the barrel increases. During another half of the rotation, the pistons move into the cylinder barrel and the barrel volume decreases. This phenomenon is responsible for drawing the fluid in and pumping it out. These pumps are positive displacement pump and can be used for both liquids and gases. Piston pumps are basically of two types:

- i. Axial piston pumps
- ii. Radial piston pumps

Axial Piston Pump

Axial piston pumps are positive displacement pumps which convert rotary motion of the input shaft into an axial reciprocating motion of the pistons. These pumps have a number of pistons (usually an odd number) in a circular array within a housing which is commonly referred to as a cylinder block, rotor or barrel. These pumps are used in jet aircraft. They are also used in small earthmoving plants such as skid loader machines. Another use is to drive the screws of torpedoes. In general, these systems have a maximum operating temperature of about 120 °C. Therefore, the leakage between cylinder housing and body block is used for cooling and lubrication of the rotating parts. This cylinder block rotates by an integral shaft aligned with the pistons. These pumps have sub-types as:

- a. Bent axis piston pumps
- b. Swash plate axial piston pump

Bent-Axis Piston Pumps

Figure 5.3.5 shows the schematic of bent axis piston pump. In these pumps, the reciprocating action of the pistons is obtained by bending the axis of the cylinder block. The cylinder block rotates at an angle which is inclined to the drive shaft. The cylinder block is turned by the drive shaft through a universal link. The cylinder block is set at an offset angle with the drive shaft. The cylinder block contains a number of pistons along its periphery. These piston rods are connected with the drive shaft flange by ball-and-socket joints. These pistons are forced in and out of their bores as the distance between the drive shaft flange and the cylinder block changes. A universal link connects the block to the drive shaft, to provide alignment and a positive drive.

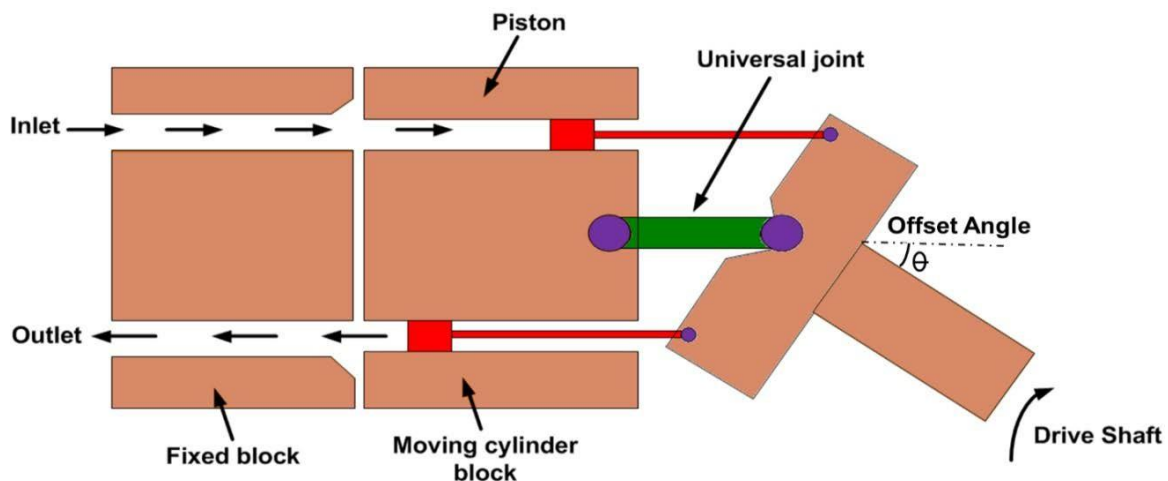


Figure 5.3.5 Bent axis piston pump

The volumetric displacement (discharge) of the pump is controlled by changing the offset angle. It makes the system simple and inexpensive. The discharge does not occur when the cylinder block is parallel to the drive shaft. The offset angle can vary from 0° to 40° . The fixed displacement units are usually provided with 23° or 30° offset angles while the variable displacement units are provided with a yoke and an external control mechanism to change the offset angle. Some designs have arrangement of moving the yoke over the center position to reverse the fluid flow direction. The flow rate of the pump varies with the offset angle θ . There is no flow when the cylinder block centerline is parallel to the drive shaft centerline (offset angle is 0°). The total fluid flow per stroke can be given as:

$$V_d = nADtan\theta$$

(5.3.1)

The flow rate of the pump can be given as:

$$V_d = nADN tan\theta$$

(5.3.2)

here, $tan\theta = \frac{S}{D}$

(5.3.3)

where S is the piston stroke, D is piston diameter, n is the number of pistons, N is the speed of pump and A is the area of piston.

Swash Plate Axial Piston Pump

A swash plate is a device that translates the rotary motion of a shaft into the reciprocating motion. It consists of a disk attached to a shaft as shown in Figure 5.3.6. If the disk is aligned perpendicular to the shaft; the disk will turn along with the rotating shaft without any reciprocating effect. Similarly, the edge of the inclined shaft will appear to oscillate along the shaft's length. This apparent linear motion increases with increase in the angle between disk and the shaft (offset angle). The apparent linear motion can be converted into an actual reciprocating motion by means of a follower that does not turn with the swash plate.

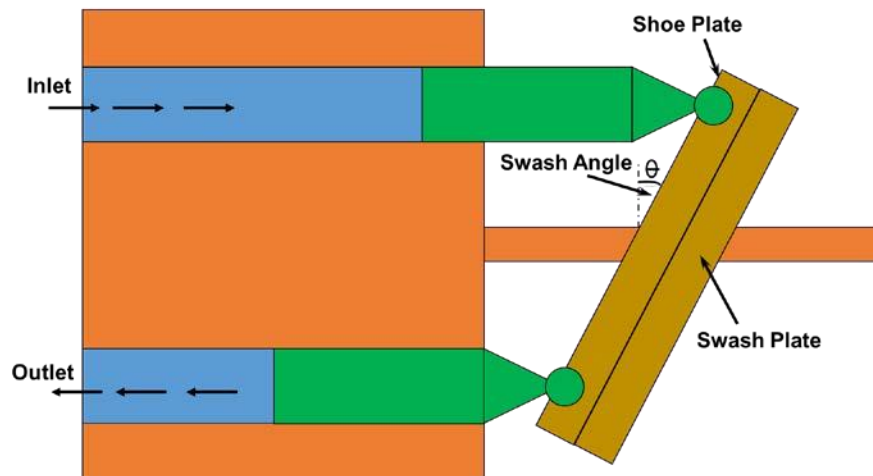


Figure 5.3.6 Swash plate piston pump

In swash plate axial piston pump a series of pistons are aligned coaxially with a shaft through a swash plate to pump a fluid. The schematic of swash plate piston pump is shown in Figure 5.3.6. The axial reciprocating motion of pistons is obtained by a swash plate that is either fixed or has variable degree of angle. As the piston barrel assembly rotates, the piston rotates around the shaft with the piston shoes in contact with the swash plate. The piston shoes follow the angled surface of the swash plate and the rotational motion of the shaft is converted into the reciprocating motion of the pistons. When the swash plate is perpendicular to the shaft; the reciprocating motion to the piston does not occur. As the swash plate angle increases, the piston follows the angle of the swash plate surface and hence it moves in and out of the barrel. The piston moves out of the cylinder barrel during one half of the cycle of rotation thereby generating an increasing volume, while during other half of the rotating cycle, the pistons move into the cylinder barrel generating a decreasing volume. This reciprocating motion of the piston results in the drawing in and pumping out of the fluid. Pump capacity can be controlled by varying the swash plate angle with the help of a separate hydraulic cylinder. The pump capacity (discharge) increases with increase in the swash plate angle and vice-versa. The cylinder block and the drive shaft in this pump are located on the same centerline. The pistons are connected through shoes and a shoe plate that bears against the swash plate. These pumps can be designed to have a variable displacement capability. It can be done by mounting

the swash plate in a movable yoke. The swash plate angle can be changed by pivoting the yoke on pintles.

Radial Piston Pump

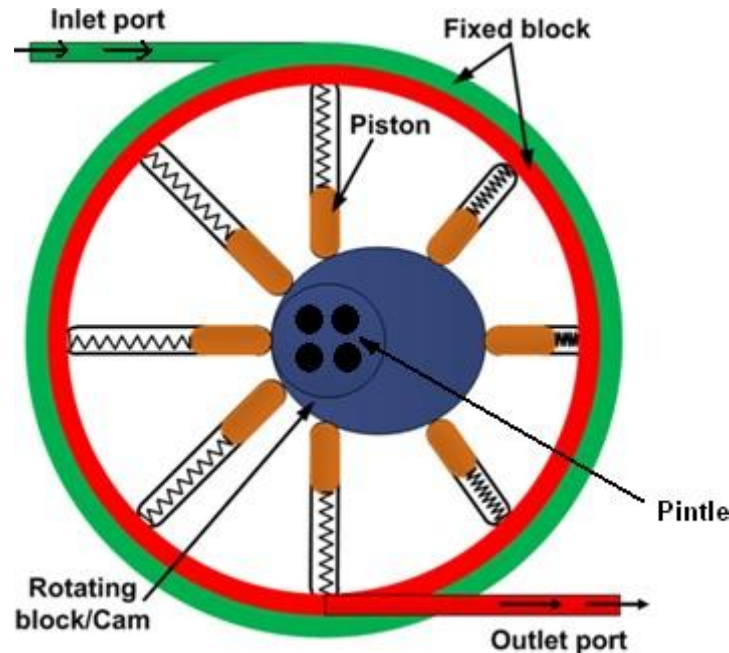


Figure 5.3.7 Radial piston pump

The typical construction of radial piston pump is shown in Figure 5.3.7. The piston pump has pistons aligned radially in a cylindrical block. It consists of a pintle, a cylinder barrel with pistons and a rotor containing a reaction ring. The pintle directs the fluid in and out of the cylinder. Pistons are placed in radial bores around the rotor. The piston shoes ride on an eccentric ring which causes them to reciprocate as they rotate. The eccentricity determines the stroke of the pumping piston. Each piston is connected to inlet port when it starts extending while it is connected to the outlet port when start retracting. This connection to the inlet and outlet port is performed by the timed porting arrangement in the pintle. For initiating a pumping action, the reaction ring is moved eccentrically with respect to the pintle or shaft axis. As the cylinder barrel rotates, the pistons on one side travel outward. This draws the fluid in as the cylinder passes the suction port of the pintle. It is continued till the maximum eccentricity is reached. When the piston passes the maximum eccentricity, pintle is forced inwards by the reaction ring. This forces the fluid to flow out of the cylinder and enter in the discharge (outlet) port of the pintle.

The radial piston pump works on high pressure (up to 1000 bar). It is possible to use the pump with various hydraulic fluids like mineral oil, biodegradable oil, HFA (oil in water), HFC (water-glycol), HFD (synthetic ester) or cutting emulsion. This is because the parts are hydrostatically balanced. It makes the pump suitable for the many applications such as machine tools (displace of cutting emulsion, supply for hydraulic equipment like cylinders), high pressure units (overload protection of presses), test rigs,

automotive sector (automatic transmission, hydraulic suspension control in upper-class cars), plastic (powder injection molding) and wind energy etc.

3. Combination Pump

There are two basic requirements for load lifting or load applying by a hydraulic ram. First, there is a need of large volume of fluid at a low pressure when the cylinder extends or retracts. The low pressure is required to overcome the frictional resistance. The second requirement is that a high pressure is needed, when the load is gripped.

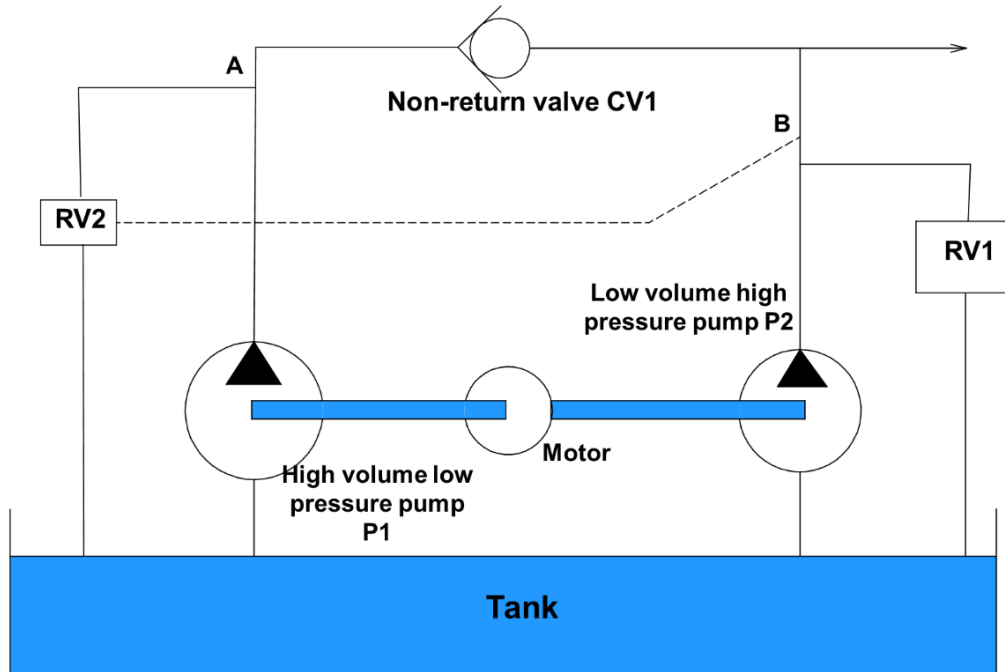


Figure 5.3.8 Combination pump

This type of requirements can be fulfilled by an arrangement as shown in figure 5.3.8. In this system two separate pumps are driven by a common electrical motor. Pump P1 is a high pressure low volume pump and pump P2 is a high volume low pressure pump. The hydraulic system is associated with relief valves RV1 and RV2 and a one-way check valve CV1. This kind of arrangement allows the fluid flow from left to right, but blocks in the reverse direction.

The pressure relief valve RV1 is a normal high pressure valve. The pressure relief valve RV2 is not operated by the pressure at point A, however, it is remotely operated by the pressure at point B. This can be achieved with the balanced piston valve. In low pressure mode both relief valves are closed and both pumps P1 and P2 deliver fluid to the load but the majority comes from the pump P2 as its capacity is higher.

When the load is in the holding mode, the pressure at B rises and relief valve RV2 opens. It results in all the fluid from pump P2 to return straight to the tank directly and the pressure at A to fall to a low value. The check valve CV1 stops the fluid from pump P1

pass it back to the tank via relief valve RV2, consequently pressure at B rises to the level set by relief valve RV1.

This kind of arrangement saves energy as the large volume of fluid from pump P2 is returned to the tank at a very low pressure, and only a small volume of fluid from pump P1 is returned at a high pressure.

In general the applications of Hydraulic Pumps can be summarized as,

- Hydraulic pumps are used to transfer power via hydraulic liquid. These pumps have a number of applications in automobiles, material handling systems, automatic transmissions, controllers, compressors and household items.
- The hand operated hydraulic pump is used in a hydraulic jack where many strokes of the pump apply hydraulic pressure to lift the ram.
- A backhoe uses an engine driven hydraulic pump to drive the articulating parts of the mechanical hoe.
- The hydraulic pumps are commonly used in the automotive vehicles especially in power steering systems.
- The lift system of tractor is operated by the hydraulic pumps. These are used in automatic transmissions and material handling systems in industries.
- Many precise controllers are developed by using hydraulic pumps. The commonly used compressor is operated by reciprocating pumps.
- The hydraulic pumps are also used in routine household systems like power lift and air-conditions. Therefore, it can be said that the hydraulic pumps have significant applications in industries as well as ones routine life.

Control Valves -1

In a hydraulic system, the hydraulic energy available from a pump is converted into motion and force by means of an actuator. The control of these mechanical outputs (motion and force) is one of the most important functions in a hydraulic system. The proper selection of control selection ensures the desired output and safe function of the system. In order to control the hydraulic outputs, different types of control valves are required. It is important to know various types of control valves and their functions. This not only helps to design a proper hydraulic system but also helps to discover the innovative ways to improve the existing systems. In this lecture and next few lectures, various types of valves will be discussed.

There are basically three types of valves employed in hydraulic systems:

1. Directional control valves
2. Flow control valves
3. Pressure control valves

1. Direction control valve

Directional control valves are used to control the distribution of energy in a fluid power system. They provide the direction to the fluid and allow the flow in a particular direction. These valves are used to control the start, stop and change in direction of the fluid flow. These valves regulate the flow direction in the hydraulic circuit. These control valves contain ports that are external openings for the fluid to enter and leave. The number of ports is usually identified by the term 'way'. For example, a valve with four ports is named as four-way valve. The fluid flow rate is responsible for the speed of actuator (motion of the output) and should controlled in a hydraulic system. This operation can be performed by using flow control valves. The pressure may increase gradually when the system is under operation. The pressure control valves protect the system by maintaining the system pressure within the desired range. Also, the output force is directly proportional to the pressure and hence, the pressure control valves ensure the desired force output at the actuator.

Directional control valves can be classified in the following manner:

1. Type of construction:
 - Poppet valves
 - Spool valves

2. Number of ports:
 - Two- way valves
 - Three – way valves
 - Four- way valves.
3. Number of switching position:
 - Two – position
 - Three - position
4. Actuating mechanism:
 - Manual actuation
 - Mechanical actuation
 - Solenoid actuation
 - Hydraulic actuation
 - Pneumatic actuation
 - Indirect actuation

Type of construction

Check Valves

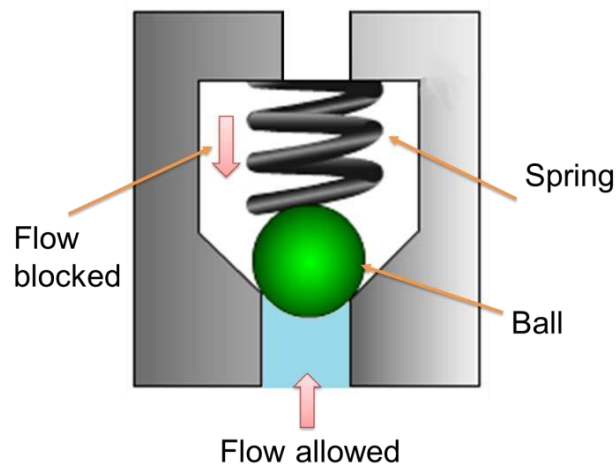


Figure 5.4.1 Inline check valve

These are unidirectional valves and permit the free flow in one direction only. These valves have two ports: one for the entry of fluid and the other for the discharge. They consist of a housing bore in which a ball or poppet is held by a small spring force. The valve having a ball as a closing member is known as a ball check valve. Various types of check valves are available for a range of applications. These valves are generally small sized, simple in construction and inexpensive. Generally, check valves are automatically operated. Human intervention or any external control system is not

required. These valves can wear out or can generate the cracks after prolonged usage and therefore they are mostly made of plastics for easy repair and replacements.

An important concept in check valves is the cracking pressure. The check valve is designed for a specific cracking pressure which is the minimum upstream pressure at which the valve operates. The simplest check valve is an inline check valve as shown in Figure 5.4.1. The ball is held against the valve seat by a spring force. It can be observed from the figure that the fluid flow is not possible from the spring side but the fluid from opposite side can pass by lifting the ball against. However, there is some pressure drop across the valve due to restriction by the spring force. Therefore these valves are not suitable for the application of high flow rate. When the operating pressure increases the valve becomes more tightly seated in this design.

The advantages of the poppet valves include no leakage, long life and suitability with high pressure applications. These valves are commonly used in liquid or gel mini-pump dispenser spigots, spray devices, some rubber bulbs for pumping air, manual air pumps, and refillable dispensing syringes. Sometimes, the right angle check valve as shown in Figure 5.4.2 is used for the high flow rate applications. The pressure drop is comparatively less in right angle check valve.

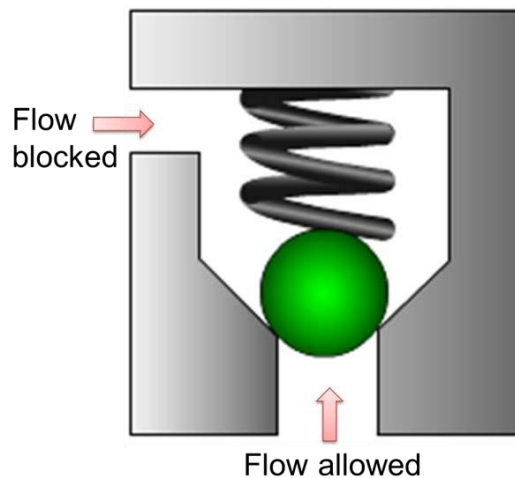


Figure 5.4.2 Right angle check valve

When the closing member is not a ball but a poppet energized by a spring is known as poppet valve. The typical poppet valve is shown in Figure 5.4.3. Some valves are meant for an application where free flow is required in one direction and restricted flow required in another direction. These types of valves are called as restriction check valve (see Figure 5.4.3). These valves are used when a direction sensitive flow rate is required. For example, the different actuator speeds are required in both the directions. The flow adjustment screw can be used to set the discharge (flow rate) in the restricted direction.

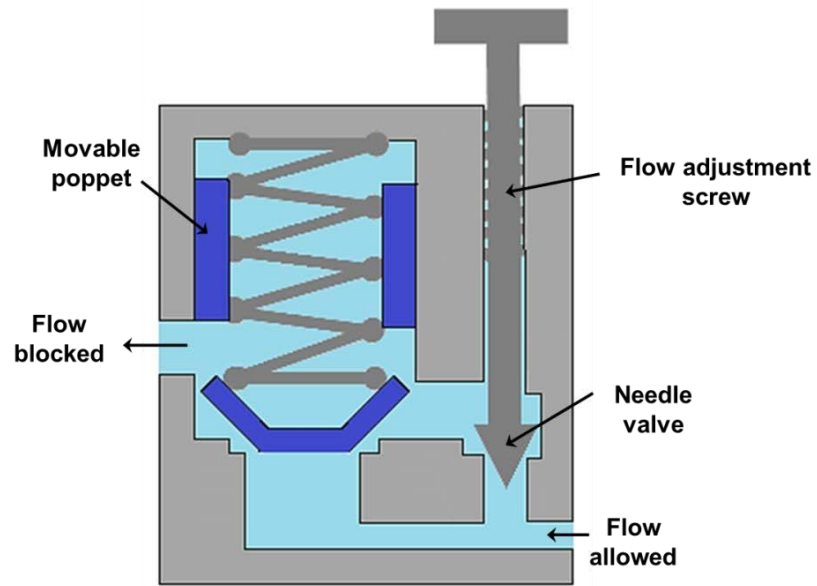


Figure 5.4.3 Restriction check valve

Another important type of check valve known as pilot operated check valve which is shown in figure 5.4.4. The function of the pilot operated check valve is similar to a normal check valve unless it gets an extra pressure signal through a pilot line. Pilot allows free flow in one direction and prevents the flow in another direction until the pilot pressure is applied. But when pilot pressure acts, the poppet opens and the flow is blocked from both the sides. These valves are used to stop the fluid suddenly.

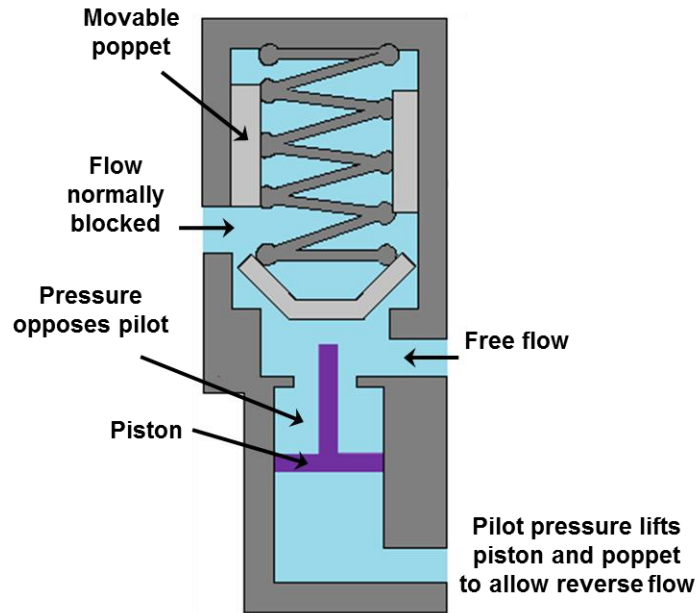


Figure 5.4.4 Pilot operated check valve

Spool valve

The spool valves derive their name from their appearance. It consists of a shaft sliding in a bore which has large groove around the circumference. This type of construction makes it look like a spool. The spool is sealed along the clearance between moving spool and housing (valve body). The quality of seal or the amount of leakage depends on the amount of clearance, viscosity of fluid and the level of the pressure. The grooves guide the fluid flow by interconnecting or blocking the holes (ports). The spool valves are categorized according to the number of operating positions and the way hydraulic lines interconnections. One of the simplest two way spool valve is shown in Figure 5.4.5. The standard terms are referred as Port 'P' is pressure port, Port 'T' is tank port and Port 'A' and Port 'B' are the actuator (or working) ports. The actuators can move in forward or backward direction depending on the connectivity of the pressure and tank port with the actuators port.

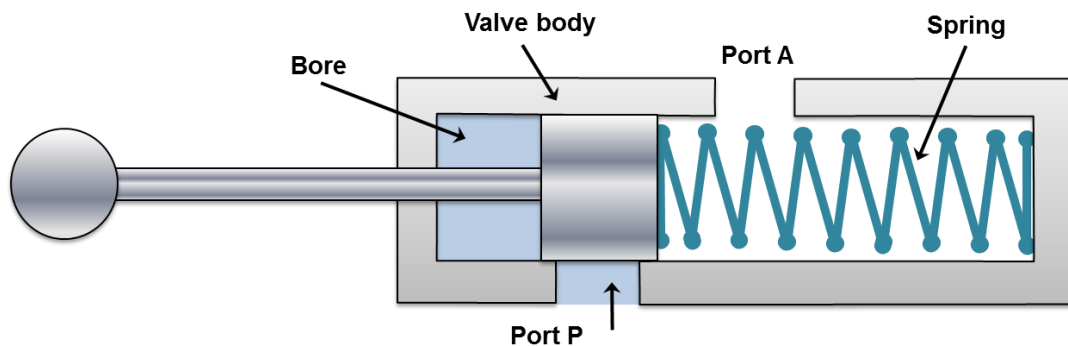


Figure 5.4.5 Valve closed

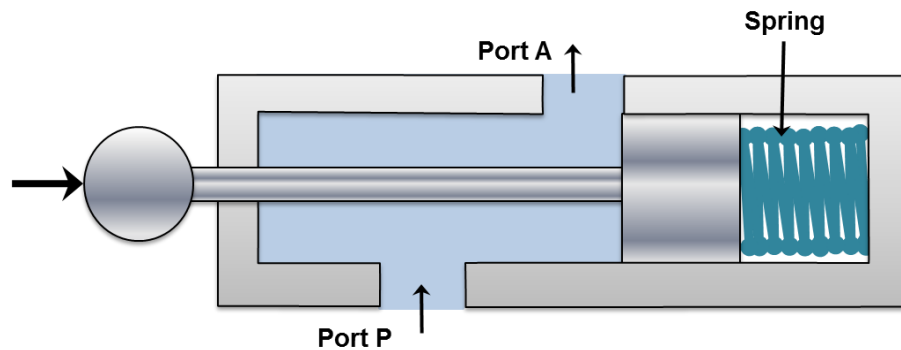


Figure 5.4.6 Valve opened by actuation

Number of ports

Two way valves

Two way valves have only two ports as shown in Figure 5.4.5 and Figure 5.4.6. These valves are also known as on-off valves because they allow the fluid flow only in direction. Normally, the valve is closed. These valves are available as normally open and normally closed function. These are the simplest type of spool valves. When actuating force is not applied to the right, the port P is not connected with port A as shown in figure 5.4.5. Therefore, the actuation does not take place. Similarly, Figure 5.4.6 shows the two-way spool valve in the open condition. Here, the pressure port P is connected with the actuator port A.

Three way valves

When a valve has one pressure port, one tank port and one actuating port as shown in Figures 5.4.7 and 5.4.8, it is known as three way valve. In this valve, the pressure port pressurizes one port and exhausts another one. As shown in figures, only one actuator port is opened at a time. In some cases a neutral position is also available when both the ports are blocked. Generally, these valves are used to operate single acting cylinders.

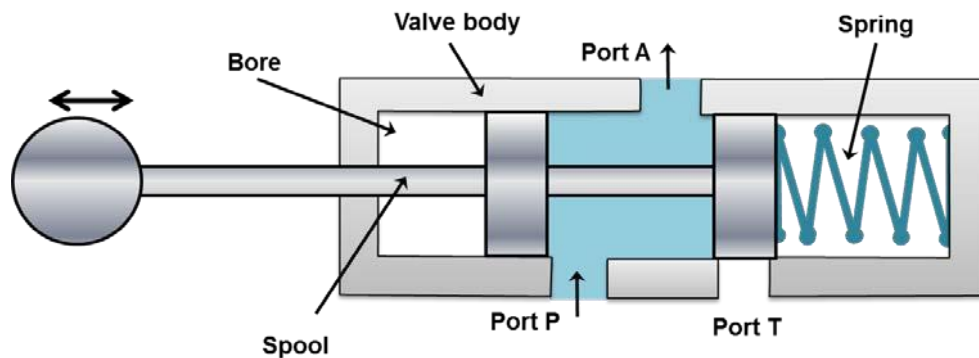


Figure 5.4.7 Three way valve: P to A connected and T is blocked

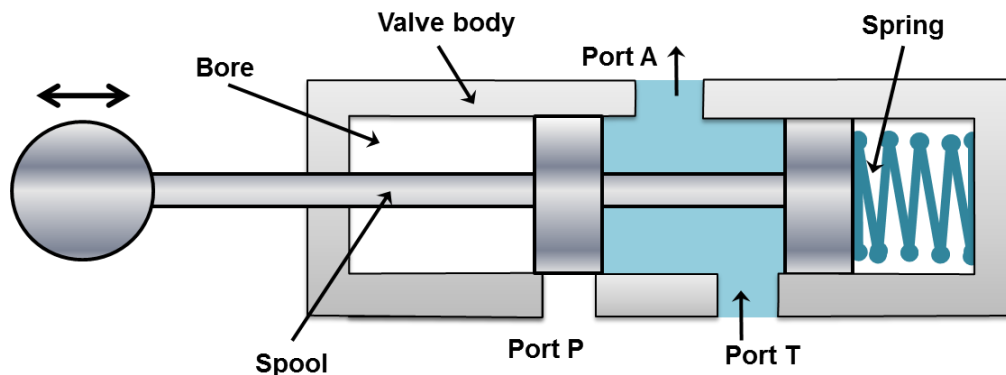


Figure 5.4.8 Three way valve in closed position

Four way valves

Figure 5.4.9 shows a four-way valve. It is generally used to operate the cylinders and fluid motors in both the directions. The four ways are: pump port P, tank port T, and two working ports A and B connected to the actuator. The primary function of a four way valve is to pressurize and exhaust two working ports A and B alternatively.

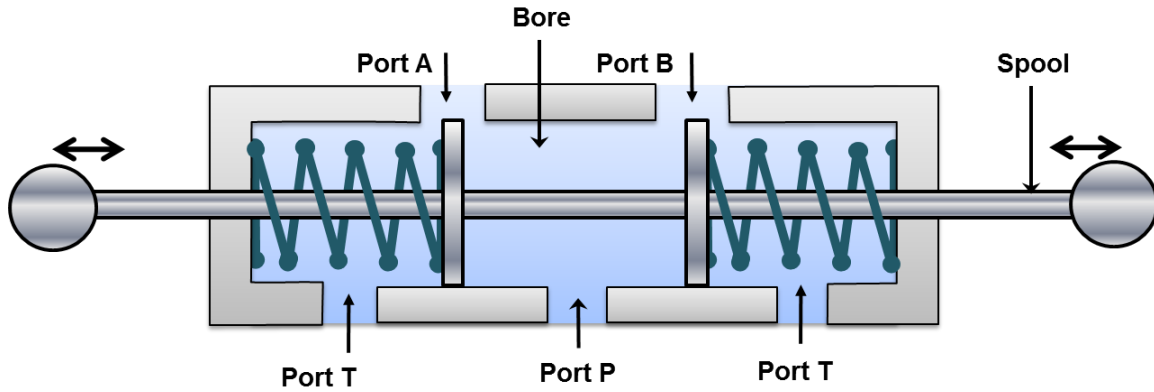


Figure 5.4.9 Three position four way valve in open center mode

Control valves -2

1. Classification of control valve according to number/ways of switching position

Three position four way (3/4) valves

Three position four way (3/4) valves are used in double-acting cylinders to perform advance, hold and return operation to the piston. Figures 5.5.1 and 5.5.2 show three position four way valves. These types of valves have three switching positions. They have a variety of possible flow path configurations but have identical flow path configuration. When the centered path is actuated, port A and B are connected with both the ports P and T respectively. In this case, valve is not active because all the ports are open to each other. The fluid flows to the tank at atmospheric pressure. In this position work cannot be done by any part of the system. This configuration helps to prevent heat buildup.

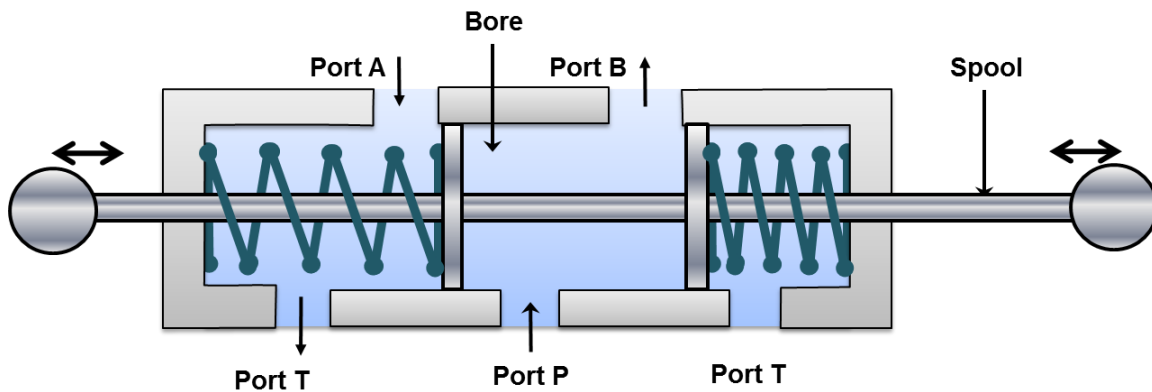


Figure 5.5.1 Three position four way valve: P to B and A to T

When left end (port B) is actuated, the port P is connected with ports B and T is connected with port A as shown in Figure 5.5.1. Similarly, when the right end is actuated the port P is connected to A and working port B is connected to port T as shown in Figure 5.5.2. The three position valves are used when the actuator is needed to stop or hold at some intermediate position. It can also be used when the multiple circuits or functions are accomplished from one hydraulic power source.

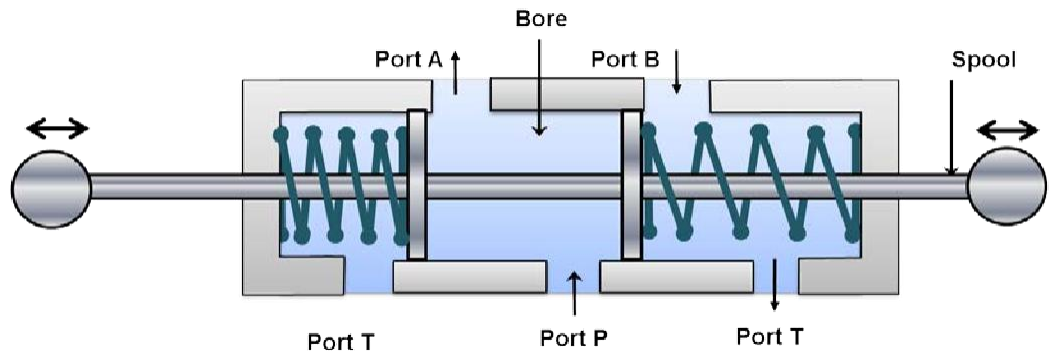


Figure 5.5.2 Three position four way valve: P to A and B to T

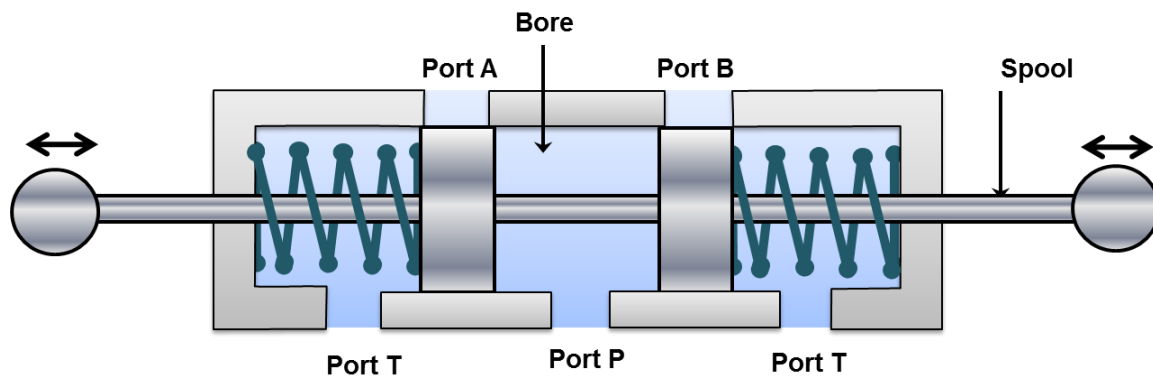


Figure 5.5.3 Three position four way valve: closed center

Figure 5.5.3 shows a three position four way valve in the closed center position. The working of the valve is similar to open center DCV. In closed center DCV all user ports (port A and port B) are closed. Therefore, these ports are hydraulically locked and the actuator cannot be moved by the external load. The pumped fluid flows through the relief valve. The pump works under the high pressure condition which not only wastes the pump power but also causes wear of the pump parts. The fluid temperature also rises due to heat generation by the pump energy transformation. The increase in fluid temperature may lead to the oxidation and viscosity drop of the fluid. The oxidation and viscosity drop reduces the pump life and leakage in the system.

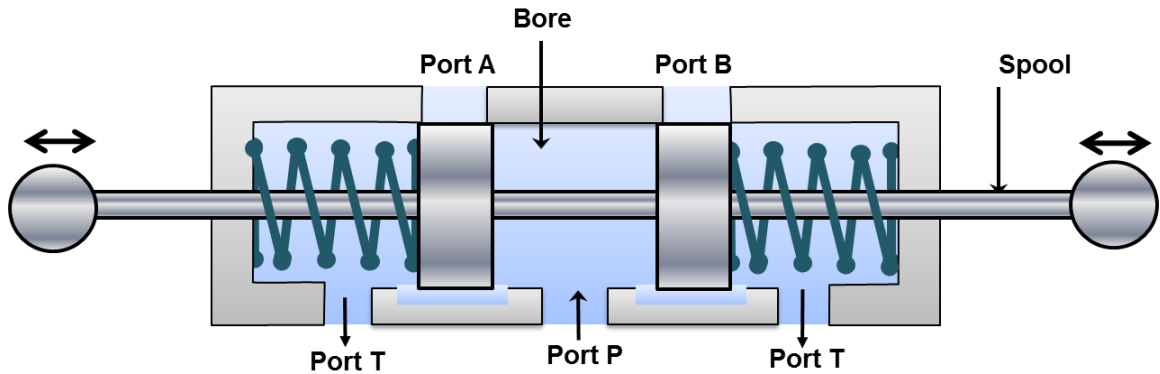


Figure 5.5.4 Tandem centered valve

Figure 5.5.4 shows a tandem center three position four way direction control valve. In this configuration, the working ports A and B are blocked and the pump port P is connected to the tank port T. Tandem center results in the locked actuator. However, pump to tank flow takes place at the atmospheric temperature. This kind of configuration can be used when the load is needed to hold. Disadvantages of high pressure pumping in case of closed center (shown in Figure 5.5.3) can be removed by using this configuration.

The regenerative center is another important type of common center configuration used in hydraulic circuits. Regenerative means the flow is generated from the system itself. Regenerative center is used when the actuator movement in one direction requires two different speeds. For example, the half-length of the stroke requires fast movement during no-load condition and remaining half-length requires slow motion during load conditions. The regenerative center saves the pump power.

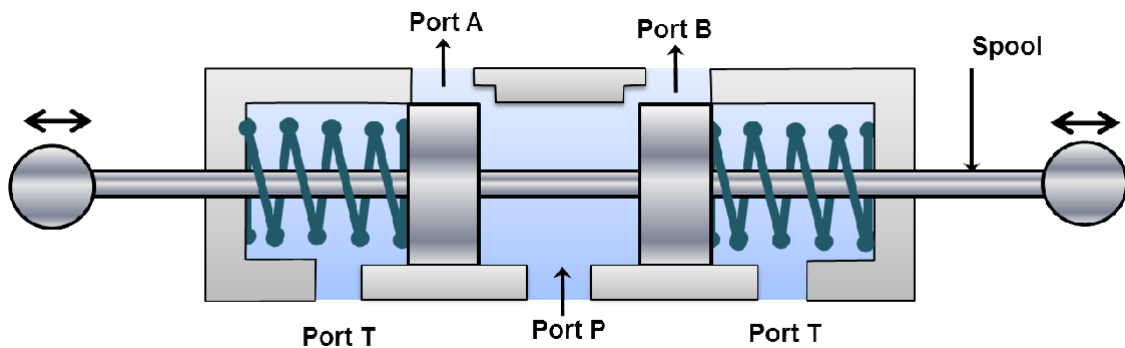


Figure 5.5.5 Regenerative Center

Figure 5.5.5 shows the regenerative configuration for the three position four way (3/4) DCV in its mid position. This configuration increases the piston speed. In the mid position pump Port P is connected to A and B, and tank port T is blocked.

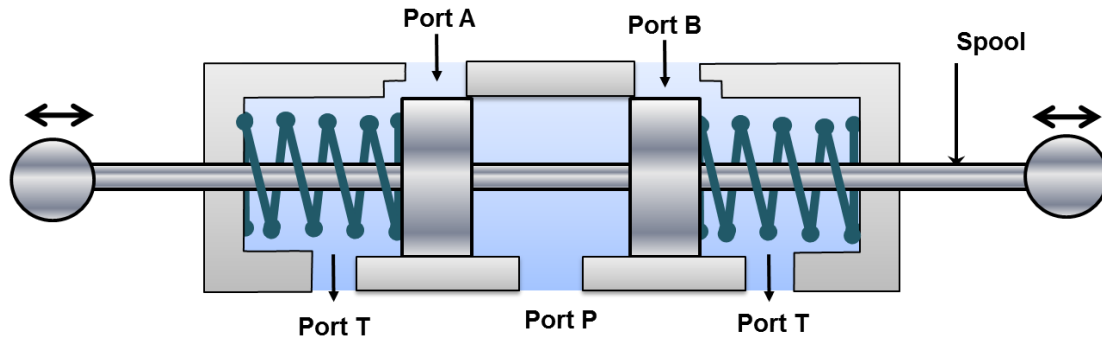


Figure 5.5.6 Floating Center

Figure 5.5.6 shows the floating center 3/4 DCV in its mid position. In this configuration, the pump port is blocked and both the working ports A and B are connected to the tank port T. Therefore, the working ports A and B can be moved freely which is reason they are called as floating center. The pumped fluid passes through the relief valve. Therefore, pump works in the high pressure condition. This configuration is used only in some special cases.

Two position four way (2/4) valves

The two position four way valves have only two switching positions and do not have any mid position. Therefore, they are also known as impulse valves. The typical connections of 2/4 valves is shown in Figures 5.5.7 and 5.5.8. These valves can be used to operate double acting cylinders. These are also used to reciprocate or hold an actuator. The operation is faster because the distance between ports of these valves is smaller. Hence, these valves are used on machines where fast reciprocation cycles are needed such as punching and stamping etc.

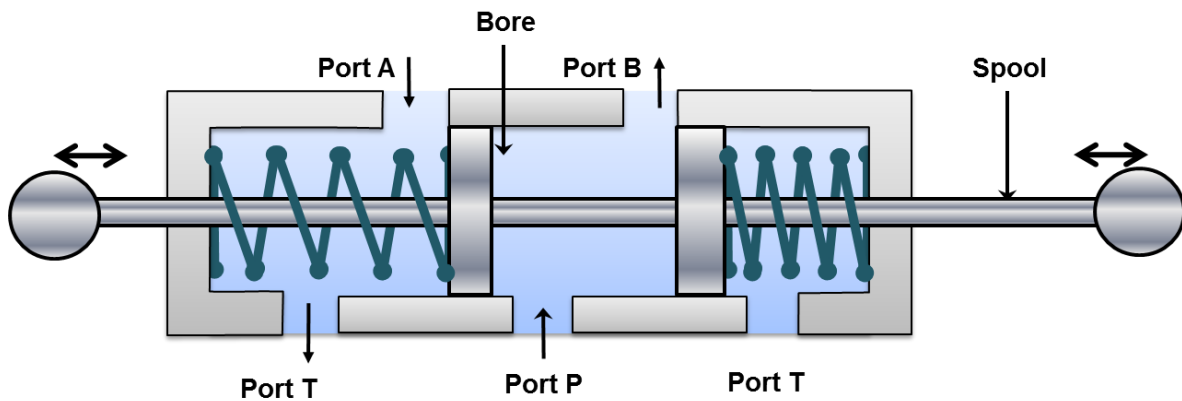


Figure 5.5.7 Two position four way DCV: P to B and A to T

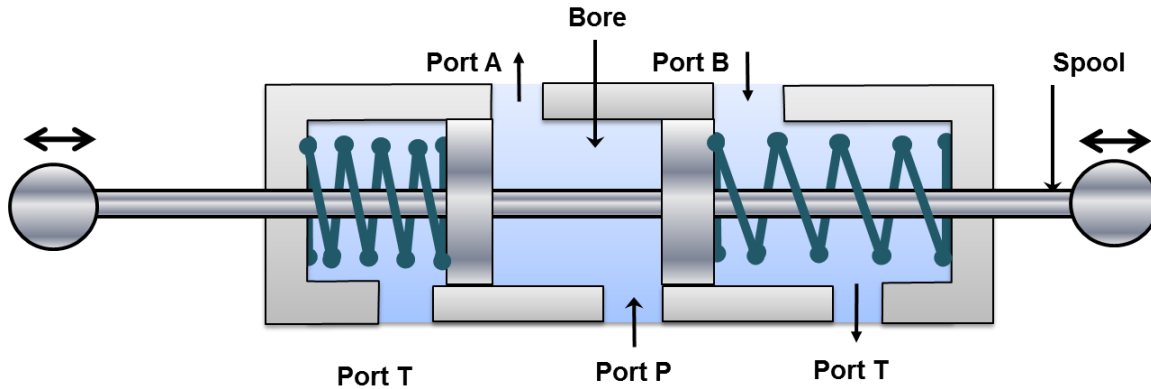


Figure 5.5.8 Two position four way DCV: P to A and B to T

2. Classification based on actuation mechanism

Manual actuation

In this type, the spool is operated manually. Manual actuators are hand lever, push button and pedals etc.

Mechanical actuation

The DCV spool can be operated by using mechanical elements such as roller and cam, roller and plunger and rack and pinion etc. In these arrangements, the spool end is of roller or a pinion gear type. The plunger or cam or rack gear is attached to the actuator. Thus, the mechanical elements gain some motion relative to the actuator (cylinder piston) which can be used for the actuation.

Solenoid actuation

The solenoid actuation is also known as electrical actuation. The schematic of solenoid actuation is shown in Figure 5.5.9. The energized solenoid coil creates a magnetic force which pulls the armature into the coil. This movement of armature controls the spool position. The main advantage of solenoid actuation is its less switching time.

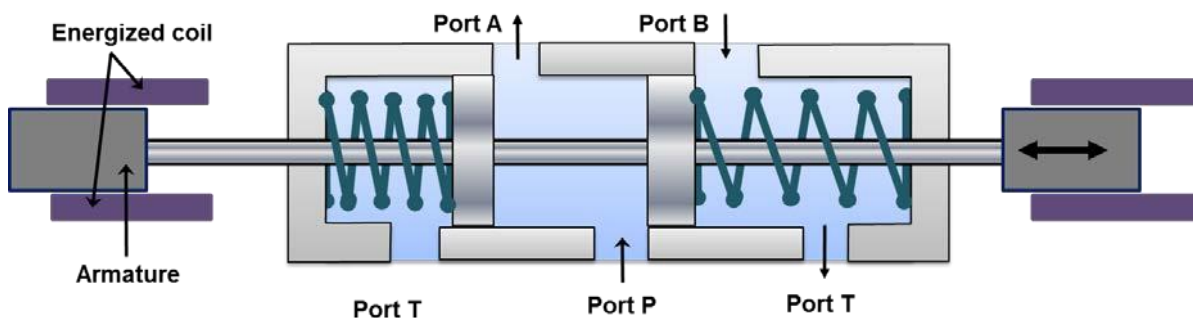


Figure 5.5.9 Working of solenoid to shift spool of valve

Hydraulic actuation

This type of actuation is usually known as pilot-actuated valve and a schematic is shown in Figure 5.5.10. In this type of actuation, the hydraulic pressure is directly applied on the spool. The pilot port is located on one end of the valve. Fluid entering from pilot port operates against the piston and forces the spool to move forward. The needle valve is used to control the speed of the actuation.

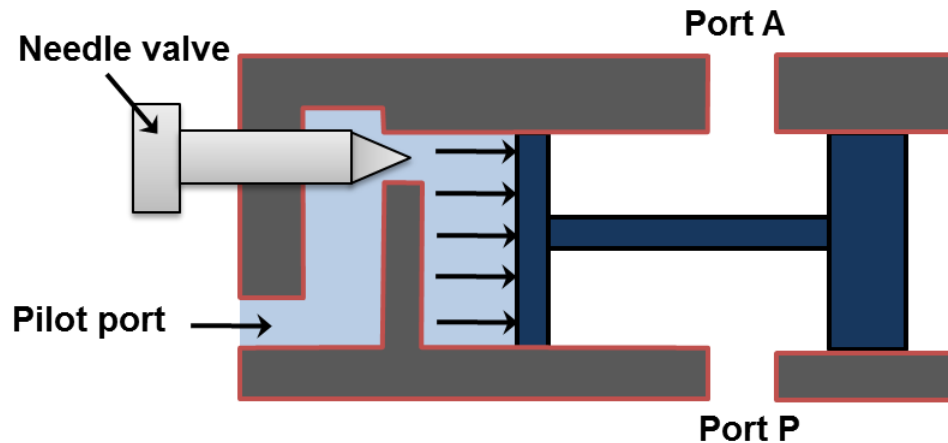


Figure 5.5.10 Pilot actuated DCV

Pneumatic actuation

DCV can also be operated by applying compressed air against a piston at either end of the valve spool. The construction of the system is similar to the hydraulic actuation as shown in Figure 5.5.10. The only difference would be the actuation medium. The actuation medium is the compressed air in pneumatic actuation system.

Indirect actuation of directional control valve

The direction control valve can be operated by manual, mechanical, solenoidal (electrical), hydraulic (pilot) and pneumatic actuations. The mode of actuation does not have any influence on the basic operation of the hydraulic circuits. Mostly, the direct actuation is restricted to use with smaller valves only because usually lot of force is not available. The availability of limited force is the greatest disadvantage of the direct actuation systems. In practice, the force required to shift the spool is quite higher. Therefore, the larger valves are often indirectly actuated in sequence. First, the smaller valve is actuated directly and the flow from the smaller valve is directed to either side of the larger valve. The control fluid can be supplied by the same circuit or by a separate circuit. The pilot valve pressure is usually supplied internally. These two valves are often incorporated as a single unit. These valves are also called as Electro-hydraulic operated DCV.

3. Flow Control Valves

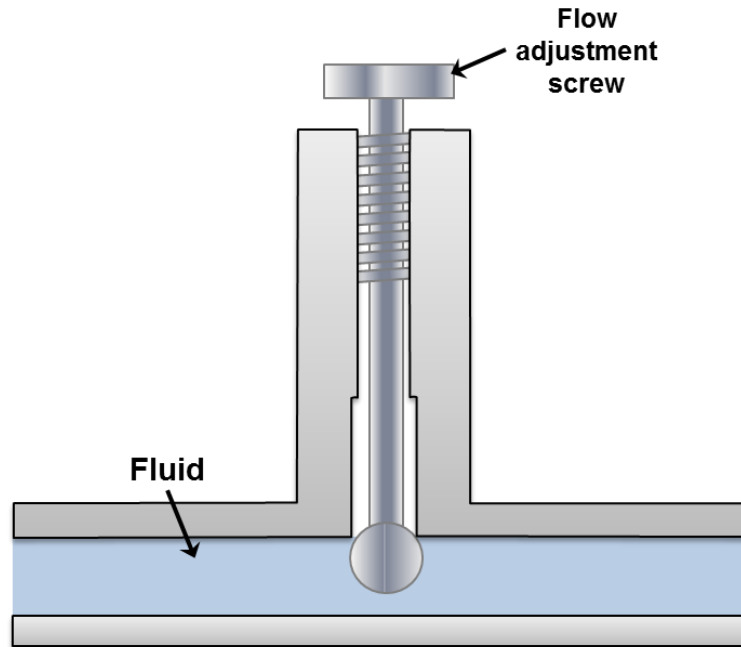


Figure 5.5.11 Flow Control Valve

In practice, the speed of actuator is very important in terms of the desired output and needs to be controlled. The speed of actuator can be controlled by regulating the fluid flow. A flow control valve can regulate the flow or pressure of the fluid. The fluid flow is controlled by varying area of the valve opening through which fluid passes. The fluid flow can be decreased by reducing the area of the valve opening and it can be increased by increasing the area of the valve opening. A very common example to the fluid flow control valve is the household tap. Figure 5.5.11 shows the schematic diagram of a flow control valve. The pressure adjustment screw varies the fluid flow area in the pipe to control the discharge rate.

The pressure drop across the valve may keep on fluctuating. In general, the hydraulic systems have a pressure compensating pump. The inlet pressure remains almost constant but the outlet pressure keeps on fluctuating depending on the external load. It creates fluctuating pressure drop. Thus, the ordinary flow control valve will not be able to maintain a constant fluid flow. A pressure compensated flow control valve maintains the constant flow throughout the movement of a spool, which shifts its position depending on the pressure. Flow control valves can also be affected by temperature changes. It is because the viscosity of the fluid changes with temperature. Therefore, the advanced flow control valves often have the temperature compensation. The temperature compensation is achieved by the thermal expansion of a rod, which compensates for the increased coefficient of discharge due to decreasing viscosity with temperature.

4. Types of Flow Control Valves

The flow control valves work on applying a variable restriction in the flow path. Based on the construction; there are mainly four types viz. plug valve, butterfly valve, ball valve and balanced valve.

Plug or glove valve

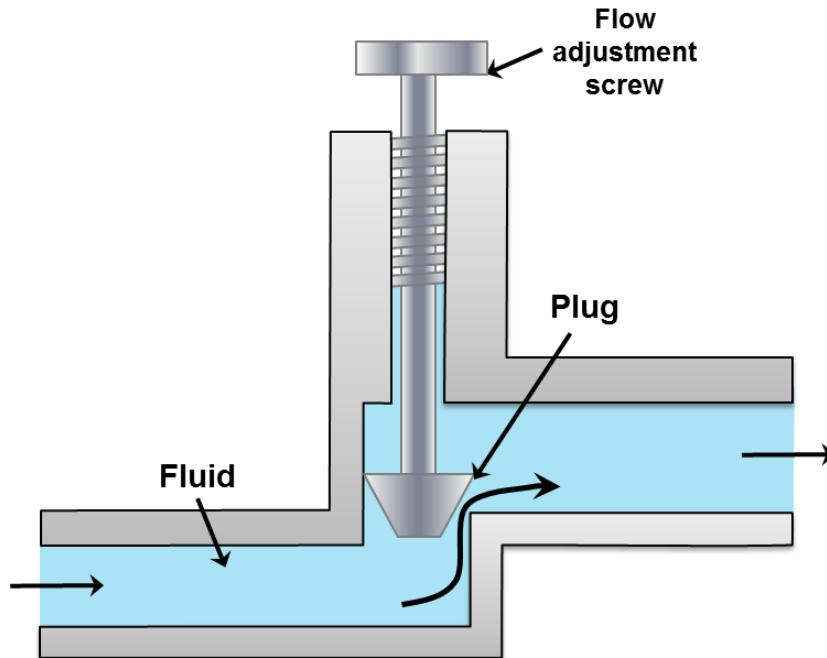


Figure 5.5.12 Plug or glove valve

The plug valve is quite commonly used valve. It is also termed as glove valve. Schematic of plug or glove valve is shown in Figure 5.5.12. This valve has a plug which can be adjusted in vertical direction by setting flow adjustment screw. The adjustment of plug alters the orifice size between plug and valve seat. Thus the adjustment of plug controls the fluid flow in the pipeline. The characteristics of these valves can be accurately predetermined by machining the taper of the plug. The typical example of plug valve is stopcock that is used in laboratory glassware. The valve body is made of glass or teflon. The plug can be made of plastic or glass. Special glass stopcocks are made for vacuum applications. Stopcock grease is used in high vacuum applications to make the stopcock air-tight.

Butterfly valve

A butterfly valve is shown in Figure 5.5.13. It consists of a disc which can rotate inside the pipe. The angle of disc determines the restriction. Butterfly valve can be made to any size and is widely used to control the flow of gas. These valves have many types which have for different pressure ranges and applications. The resilient butterfly valve uses the flexibility of rubber and has the lowest pressure rating. The high performance butterfly valves have a slight offset in the way the disc is positioned. It increases its sealing ability and decreases the wear. For high-pressure systems, the triple offset butterfly valve is suitable which makes use of a metal seat and is therefore able to withstand high pressure. It has higher risk of leakage on the shut-off position and suffer from the dynamic torque effect. Butterfly valves are favored because of their lower cost and lighter weight. The disc is always present in the flow therefore a pressure drop is induced regardless of the valve position.

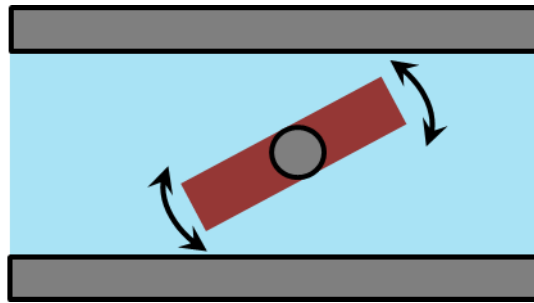


Figure 5.5.13 Butterfly valve

Ball Valve

The ball valve is shown in Figure 5.5.14. This type of flow control valve uses a ball rotated inside a machined seat. The ball has a through hole as shown in Figure 5.5.14. It has very less leakage in its shut-off condition. These valves are durable and usually work perfectly for many years. They are excellent choice for shutoff applications. They do not offer fine control which may be necessary in throttling applications. These valves are widely used in industries because of their versatility, high supporting pressures (up to 1000 bar) and temperatures (up to 250°C). They are easy to repair and operate.

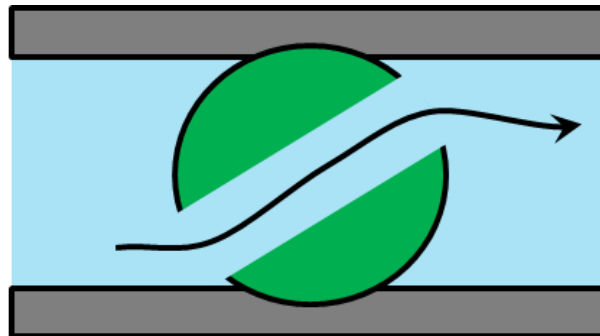


Figure 5.5.14 Ball valve

Balanced valve

Schematic of a balanced valve is shown in figure 5.5.15. It comprises of two plugs and two seats. The opposite flow gives little dynamic reaction onto the actuator shaft. It results in the negligible dynamic torque effect. However, the leakage is more in these kind of valves because the manufacturing tolerance can cause one plug to seat before the other. The pressure-balanced valves are used in the houses. They provide water at nearly constant temperature to a shower or bathtub despite of pressure fluctuations in either the hot or cold supply lines.

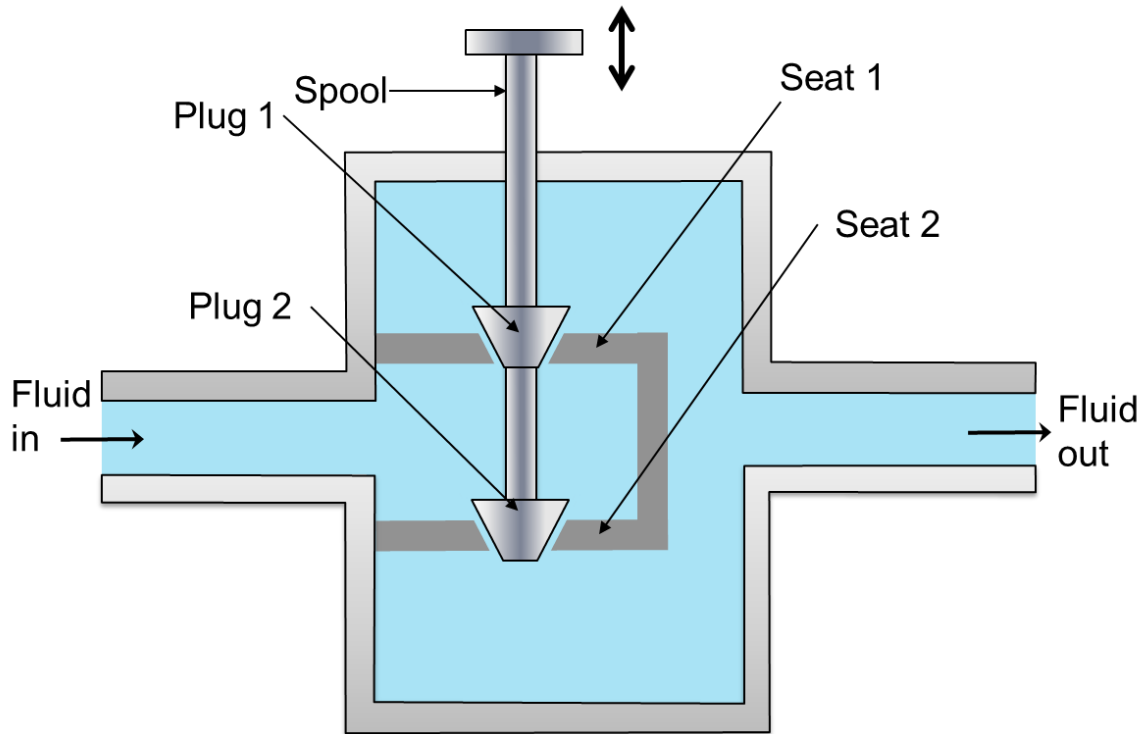


Figure 5.5.15 Balanced valve

Pressure relief valves

The pressure relief valves are used to protect the hydraulic components from excessive pressure. This is one of the most important components of a hydraulic system and is essentially required for safe operation of the system. Its primary function is to limit the system pressure within a specified range. It is normally a closed type and it opens when the pressure exceeds a specified maximum value by diverting pump flow back to the tank. The simplest type valve contains a poppet held in a seat against the spring force as shown in Figure 5.6.1. The fluid enters from the opposite side of the poppet. When the system pressure exceeds the preset value, the poppet lifts and the fluid is escaped through the orifice to the storage tank directly. It reduces the system pressure and as the pressure reduces to the set limit again the valve closes. This valve does not provide a flat cut-off pressure limit with flow rate because the spring must be deflected more when the flow rate is higher. Various types of pressure control valves are discussed in the following sections:

1. *Direct type of relief valve*

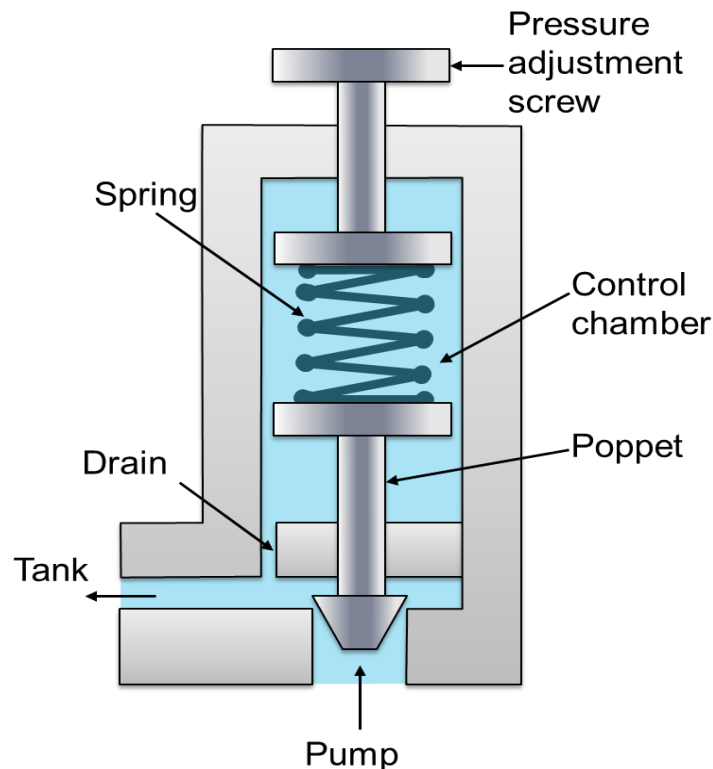


Figure 5.6.1 Pressure Relief Valve

Schematic of direct pressure relief valve is shown in figure 5.6.1. This type of valves has two ports; one of which is connected to the pump and another is connected to the tank. It consists of a spring chamber where poppet is placed with a spring force. Generally, the spring is adjustable to set the maximum pressure limit of the system. The poppet is held in position by combined effect of spring force and dead weight of spool. As the pressure exceeds this combined force, the poppet raises and excess fluid bypassed to the reservoir (tank). The poppet again reseats as the pressure drops below the pre-set value. A drain is also provided in the control chamber. It sends the fluid collected due to small leakage to the tank and thereby prevents the failure of the valve.

2. Unloading Valve

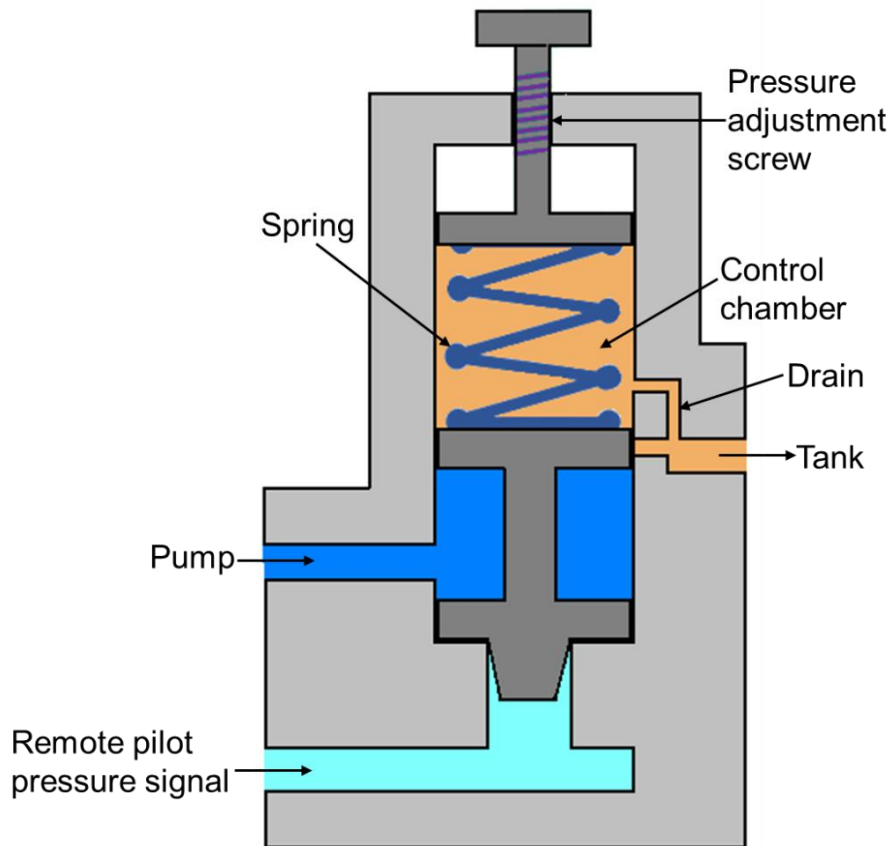


Figure 5.6.2 Unloading Valve

The construction of unloading valve is shown in Figure 5.6.2. This valve consists of a control chamber with an adjustable spring which pushes the spool down. The valve has two ports: one is connected to the tank and another is connected to the pump. The valve is operated by movement of the spool. Normally, the valve is closed and the tank port is also closed. These valves are used to permit a pump to operate at the minimum load. It works on the same principle as direct control valve that the pump delivery is diverted to the tank when sufficient pilot pressure is applied to move the spool. The pilot pressure maintains a static pressure to hold the valve opened. The pilot pressure holds the valve until the pump delivery is needed in the system. As the pressure is needed in the

hydraulic circuit; the pilot pressure is relaxed and the spool moves down due to the self-weight and the spring force. Now, the flow is diverted to the hydraulic circuit. The drain is provided to remove the leaked oil collected in the control chamber to prevent the valve failure. The unloading valve reduces the heat buildup due to fluid discharge at a preset pressure value.

3. Sequence valve

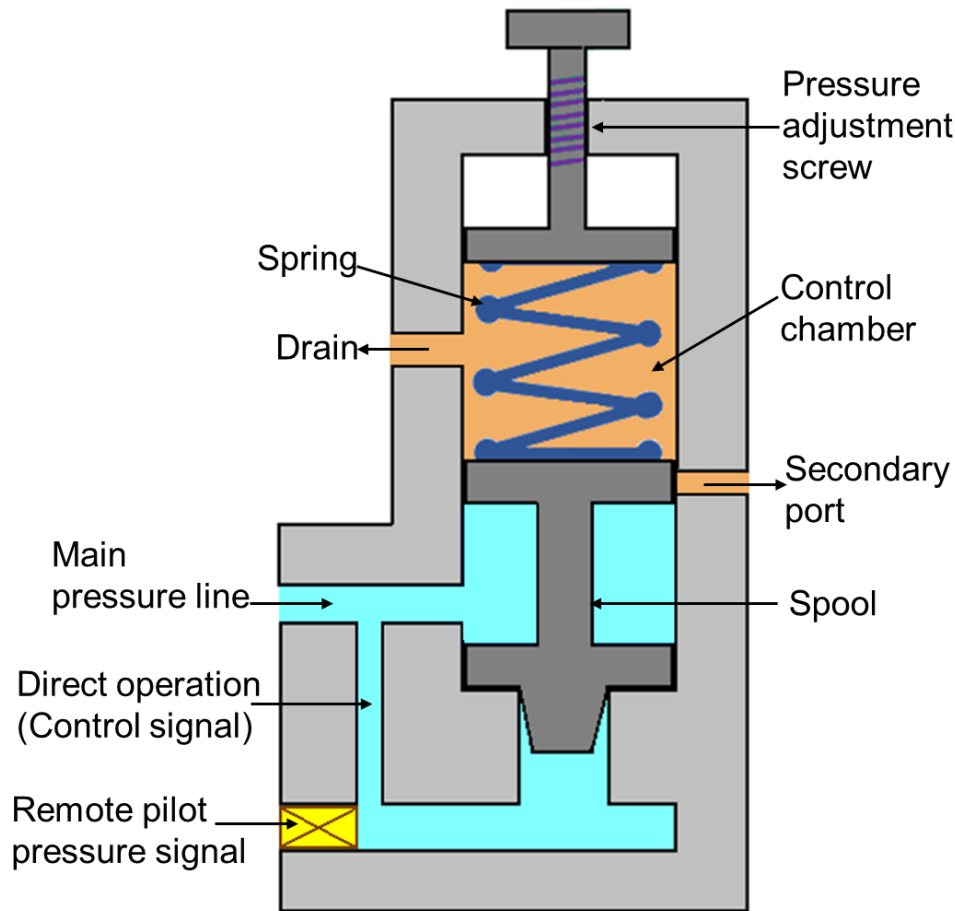


Figure 5.6.3 Sequence valve

The primary function of this type of valve is to divert flow in a predetermined sequence. It is used to operate the cycle of a machine automatically. A sequence valve may be of direct-pilot or remote-pilot operated type.

Schematic of the sequence valve is shown in Figure 5.6.3. Its construction is similar to the direct relief valve. It consists of the two ports; one main port connecting the main pressure line and another port (secondary port) is connected to the secondary circuit. The secondary port is usually closed by the spool. The pressure on the spool works against the spring force. When the pressure exceeds the preset value of the spring; the spool lifts and the fluid flows from the primary port to the secondary port. For remote

operation; the passage used for the direct operation is closed and a separate pressure source for the spool operation is provided in the remote operation mode.

4. Counterbalance Valve

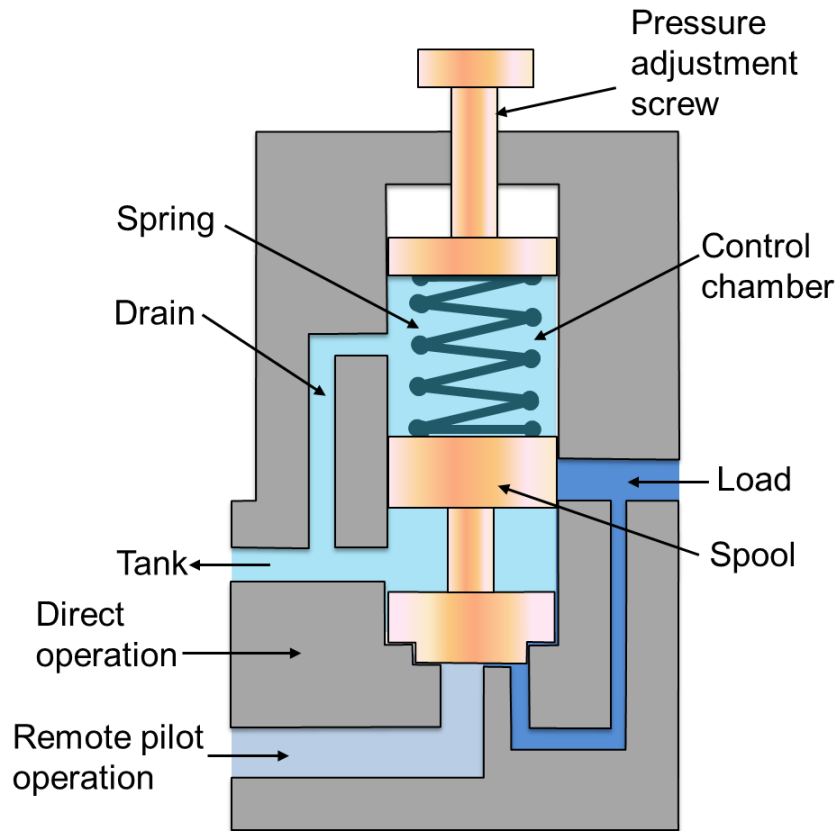


Figure 5.6.4 Counter Balance Valve

The schematic of counterbalance valve is shown in Figure 5.6.4. It is used to maintain the back pressure and to prevent a load from falling. The counterbalance valves can be used as breaking valves for decelerating heavy loads. These valves are used in vertical presses, lift trucks, loaders and other machine tools where position or hold suspended loads are important. Counterbalance valves work on the principle that the fluid is trapped under pressure until pilot pressure overcomes the pre-set value of spring force. Fluid is then allowed to escape, letting the load to descend under control. This valve is normally closed until it is acted upon by a remote pilot pressure source. Therefore, a lower spring force is sufficient. It leads to the valve operation at the lower pilot pressure and hence the power consumption reduces, pump life increases and the fluid temperature decreases.

5. Pressure Reducing Valve

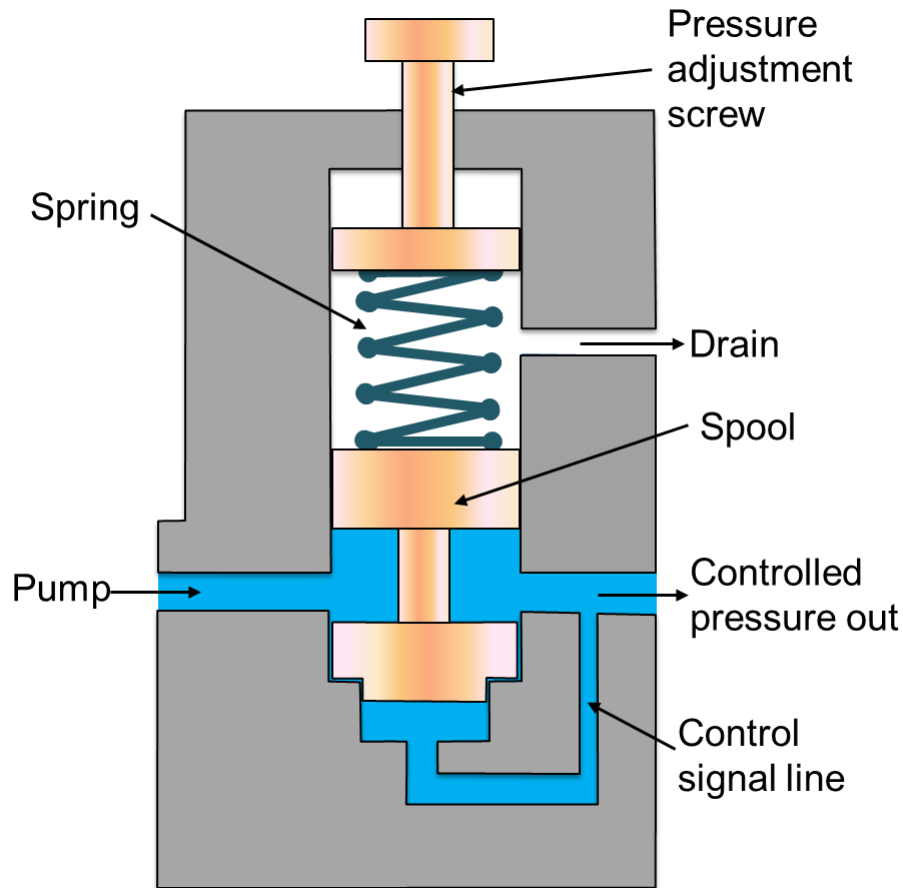


Figure 5.6.5 Pressure Reducing Valve

Sometimes a part of the system may need a lower pressure. This can be made possible by using pressure reducing valve as shown in Figure 5.6.5. These valves are used to limit the outlet pressure. Generally, they are used for the operation of branch circuits where the pressure may vary from the main hydraulic pressure lines. These are open type valve and have a spring chamber with an adjustable spring, a movable spool as shown in figure. A drain is provided to return the leaked fluid in the spring (control) chamber. A free flow passage is provided from inlet port to the outlet port until a signal from the outlet port tends to throttle the passage through the valve. The pilot pressure opposes the spring force and when both are balanced, the downstream is controlled at the pressure setting. When the pressure in the reduced pressure line exceeds the valve setting, the spool moves to reduce the flow passage area by compressing the spring. It can be seen from the figure that if the spring force is more, the valve opens wider and if the controlled pressure has greater force, the valves moves towards the spring and throttles the flow.

Graphical representation of hydraulic and pneumatic elements

The hydraulic and pneumatic elements such as cylinders and valves are connected through pipelines to form a hydraulic or a pneumatic circuit. It is difficult to represent the complex functioning of these elements using sketches. Therefore graphical symbols are used to indicate these elements. The symbols only specify the function of the element without indicating the design of the element. Symbols also indicate the actuation method, direction of flow of air and designation of the ports. Symbols are described in various documents like DIN24300, BS2917, ISO1219 and the new ISO5599, CETOP RP3 and the original American JIC and ANSI symbols.

The symbol used to represent an individual element display the following characteristics:

- Function
- Actuation and return actuation methods
- Number of connections
- Number of switching positions
- General operating principle
- Simplified representation of the flow path

The symbol does not represent the following characteristics:

- Size or dimensions of the component
- Particular manufacturer, methods of construction or costs
- Operation of the ports
- Any physical details of the elements
- Any unions or connections other than junctions

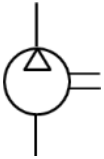
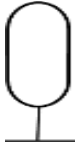
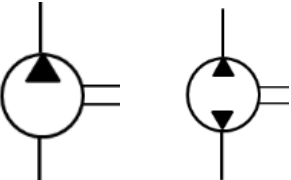
Earlier the ports were designated with letter system. Now as per ISO5599 the ports are designated based on number system. The port designations are shown in table 5.7.1

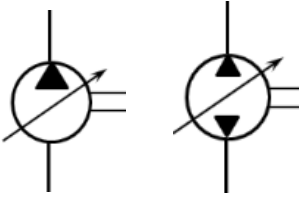
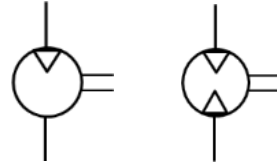
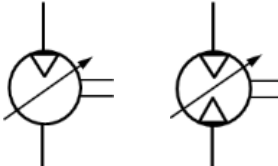
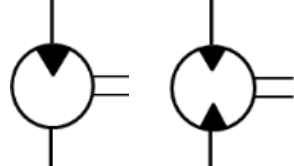
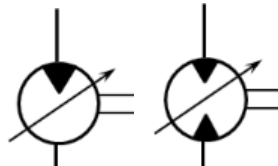
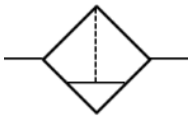
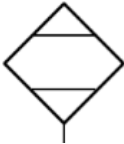
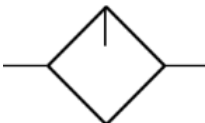
Table 5.7.1 Symbols for ports

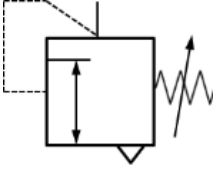
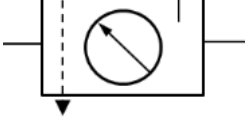
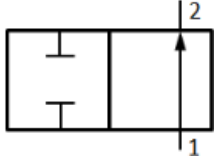
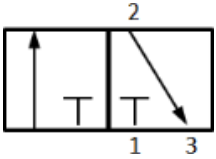
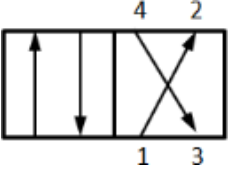
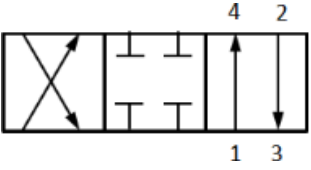
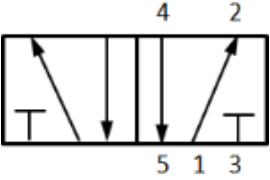
Port	Letter system	Number system
Pressure port	P	1
Working port	A	4
Working port	B	2
Exhaust port	R	5
Exhaust port	S	3
Pilot port	Z	14
Pilot port	Y	12

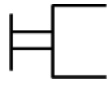
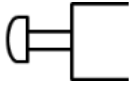
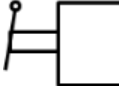

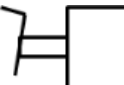
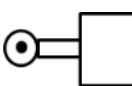
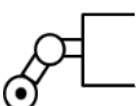

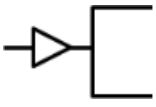


The graphical representation, designation and explanation of various components and equipments used in hydraulic and pneumatic system are given in table 5.7.2. Readers are suggested to study these representations carefully.

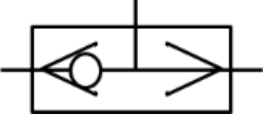
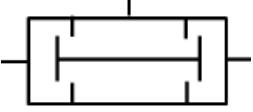
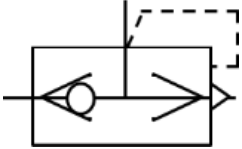

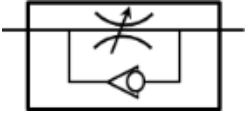
Table 5.7.2 Graphical symbols of hydraulic / pneumatic elements and equipments

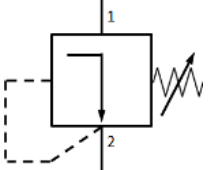
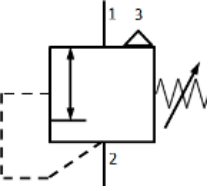
SYMBOL	DESIGNATION	EXPLANATION
Energy supply		
	Air compressor	One direction of rotation only with constant displacement volume
	Air receiver	Compressed air from the compressor is stored and diverted to the system when required
		One direction and two direction of rotation with constant displacement volume

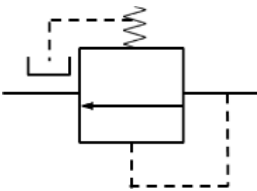
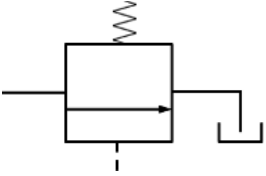
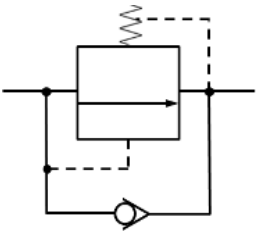
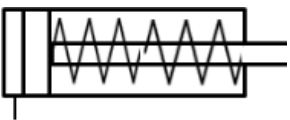
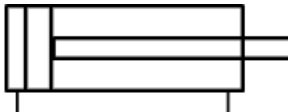
	<p>Hydraulic pump</p>	<p>One direction and two direction of rotation with variable displacement</p>
<p>Rotary actuators</p>		
	<p>Pneumatic motor</p>	<p>One direction and two direction of rotation with constant displacement volume</p>
		<p>One direction and two direction of rotation with variable displacement</p>
	<p>Hydraulic motor</p>	<p>One direction and two direction of rotation with constant displacement volume</p>
		<p>One direction and two direction of rotation with variable displacement</p>
<p>Service units</p>		
	<p>Air filter</p>	<p>This device is a combination of filter and water separator</p>
	<p>Dryer</p>	<p>For drying the air</p>
	<p>Lubricator</p>	<p>For lubrication of connected devices, small amount of oil is added to</p>

		the air flowing through this device
	Regulator	To regulate the air pressure
	FRL unit	Combined filter, regulator and lubricator system
Direction control valves (DCVs)		
	2/2 way valve	Two closed ports in the closed neutral position and flow during actuated position
	3/2 way valve	In the first position flow takes place to the cylinder In the second position flow takes out of the cylinder to the exhaust (Single acting cylinder)
	4/2 way valve	For double acting cylinder all the ports are open
	4/3 way valve	Two open positions and one closed neutral position
	5/2 way valve	Two open positions with two exhaust ports

Direction control valve actuation methods		
	General manual actuation	Manual operation of DCV
	Push button actuation	
	Lever actuation	
	Detent lever actuation	
	Foot pedal actuation	Mechanical actuation of DCV
	Roller lever actuation	
	Idle return roller actuation	
	Spring actuation	
	Direct pneumatic actuation	Pneumatic actuation of DCV
Non return valves		
	Check valve	Allows flow in one direction and blocks flow in other direction
	Spring loaded check valve	

	Shuttle/ OR valve	When any one of the input is given the output is produced
	AND valve	Only when both the inputs are given output is produced
	Quick exhaust valve	For quick exhaust of air to cause rapid extension/retraction of cylinder
Flow control valves		
	Flow control valve	To allow controlled flow
	Flow control valve with one way adjustment	To allow controlled flow in one direction and free flow in other

Pressure control valves		
	Pressure relieving valve	Non relieving type
		Relieving type with overload being vented out

	<p>Pressure reducing valve</p>	<p>Maintains the reduced pressure at specified location in hydraulic system</p>
	<p>Unloading valve</p>	<p>Allows pump to build pressure to an adjustable pressure setting and then allow it to be discharged to tank</p>
	<p>Counter balance valve</p>	<p>Controls the movement of vertical hydraulic cylinder and prevents its descend due to external load weight</p>
<p>Actuators</p>		
	<p>Single acting cylinder</p>	<p>Spring loaded cylinder with retraction taking place by spring force</p>
	<p>Double acting cylinder</p>	<p>Both extension and retraction by pneumatic/hydraulic force</p>

Design of Hydraulic Circuit

Problem Definition: Package lifting device

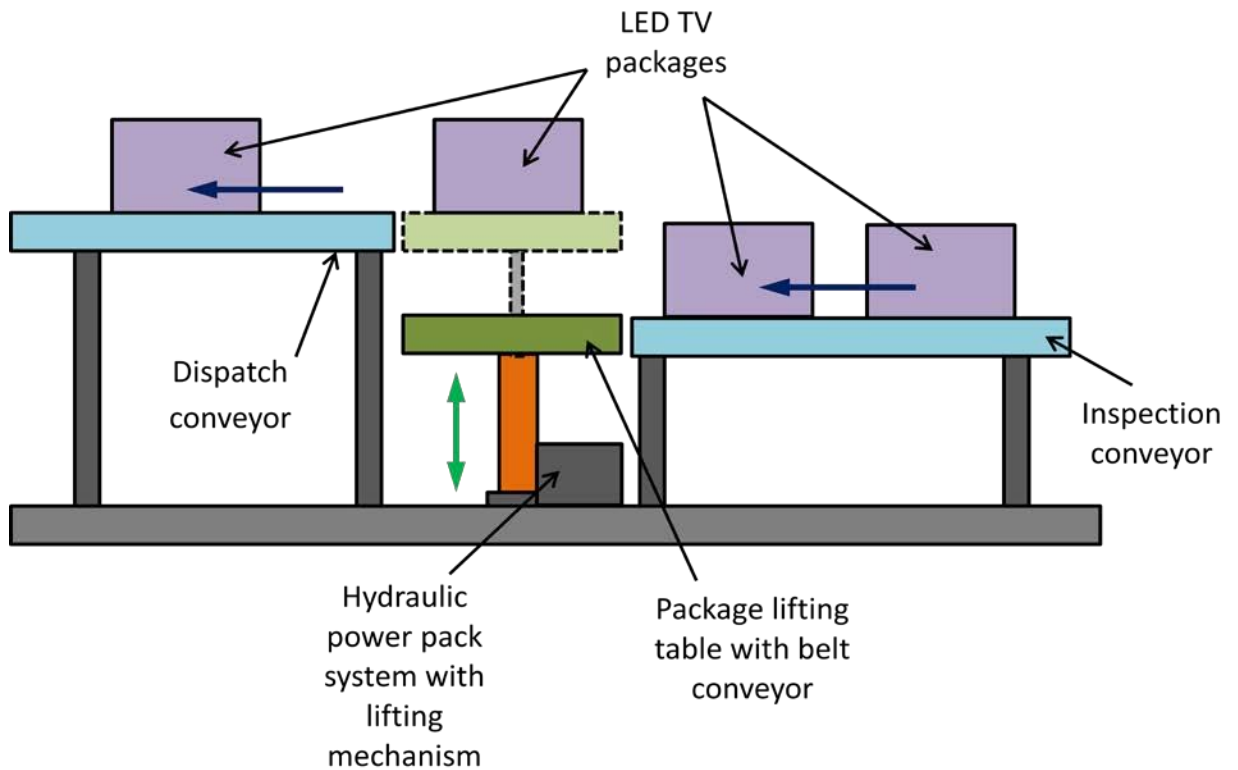


Figure 5.8.1 Schematic of a Package lifting system for LED TVs

For a dispatch station of a LED TV production house, design a package lifting device to lift packages containing 21" to 51" LED TVs from the inspection conveyor to the dispatch conveyor. Draw the hydraulic circuit diagram. List the components. Readers are requested to assume suitable data.

Solution

By applying the principle of hydraulics and after studying the various sensors, pumps, valves and hydraulic actuators, the proposed hydraulic circuit is shown in Figure 5.8.1. Components required are listed in table 5.8.1.

Table 5.8.1 List of Components

S. No.	Item No.	Quantity	Description
1	1A	1	Two direction Hydraulic Motor with constant displacement volume
2	0Z1	1	Hydraulic Power Pack
3	0Z2	1	Pressure gauge
4	1V1	1	Shut-off valve
5	1V2	1	Pressure relief valve
6	1S	1	Flow sensor
7		5	Hose line
8		2	Branch tee

Proposed hydraulic circuit and its operation

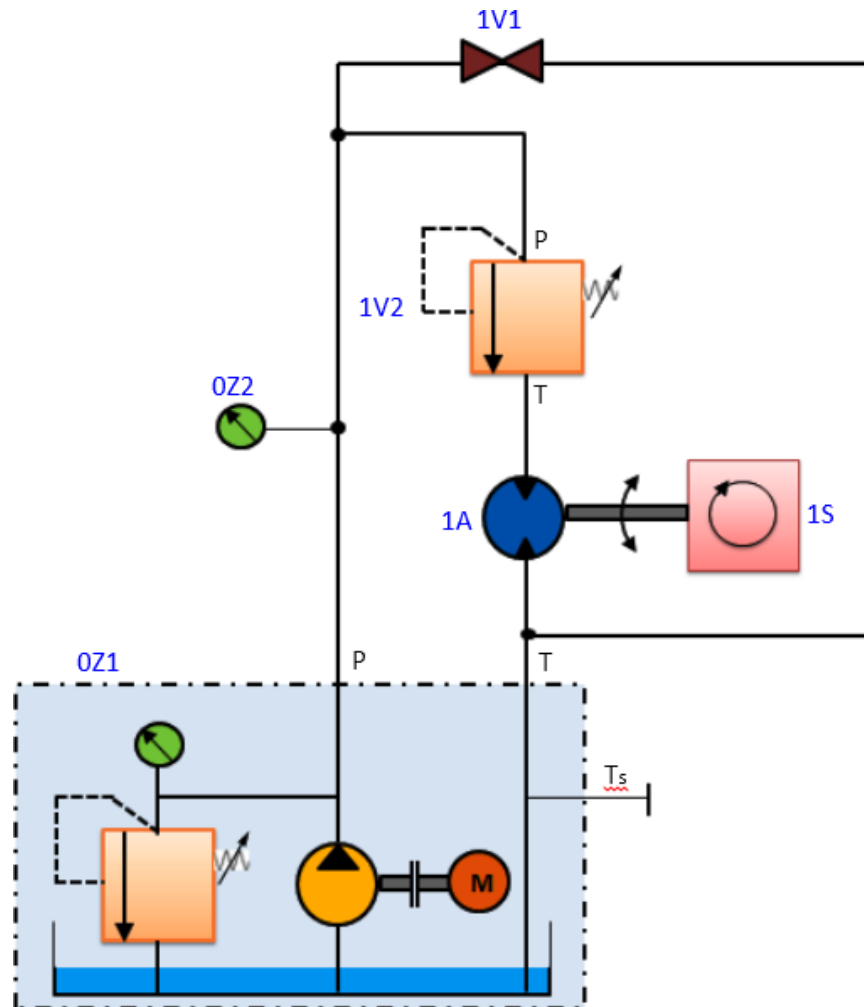


Figure 5.8.2 Hydraulic circuit design for package lifting device

Figure 5.8.2 shows the circuit design for package lifting device. The two direction hydraulic motor is run by using a hydraulic power pack. Required valves and pressure sensors are also included for desired control action. Readers are requested to carefully read the circuit and comprehend the circuit.

Once the hydraulic circuit has been assembled and checked, valve 1V1 and pressure relief valve 1V2 can be operated in sequence to obtain the rotary motion of hydraulic motor in required direction (clockwise/counter clockwise). This rotary motion can further be converted into linear motion by using suitable motion converter mechanism viz. Rack and pinion mechanism. Linear motion is used to lift the packages. It is required to develop a PID based controller to control the operation of the valves. The pressure gauge and flow sensor are used to monitor the operation continuously.

Problem Definition: Furnace door control

Design a hydraulic circuit for a furnace door to be opened and closed. Figure 5.8.3 shows the schematic of the furnace and its door that to be controlled. Propose a suitable hydraulic technology. List the components. Draw the hydraulic circuit diagram. Compute stroke speeds and stroke times by assuming suitable data.

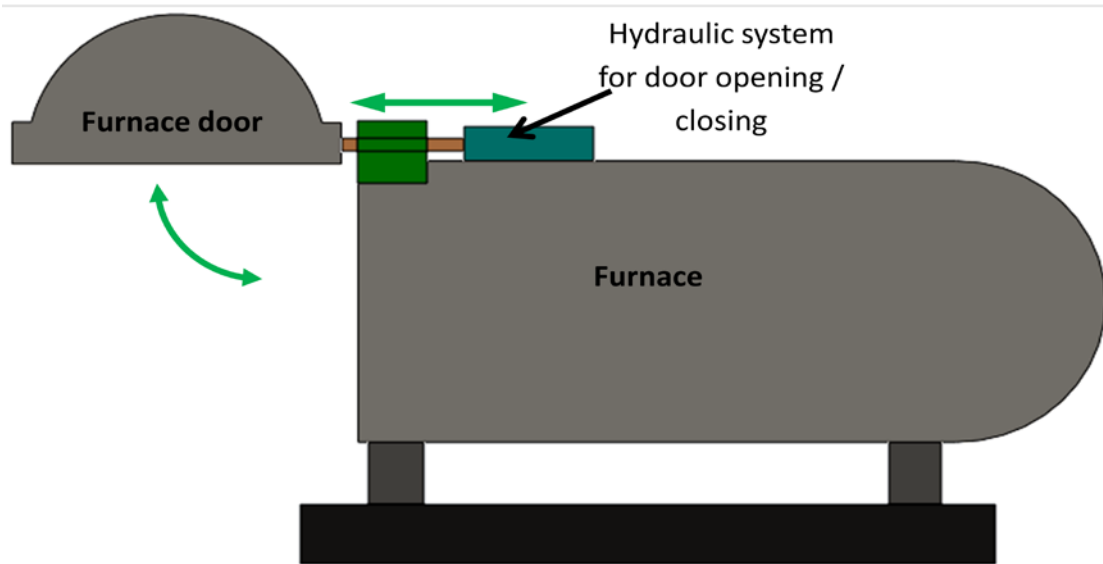


Figure 5.8.3 Furnace and its door

Solution

A double-acting cylinder can be used to control the movements of furnace door. The cylinder is to be activated by a 4/2-way valve with spring return. This will ensure that the door opens only as long as the valve is actuated. When the valve actuating lever is released, the door closes again. Table 5.8.2 lists the required hydraulic and mechanical components. Figure 5.8.4 shows the proposed hydraulic circuit.

Table 5.8.2 List of components

S. No.	Item No.	Quantity	Description
1	0Z1	1	Hydraulic Power Pack
2	0Z2	1	Pressure gauge
3	1S1, 1S2	2	Pressure sensor
4	0V	1	Pressure relief valve
5	1V	1	4/2 way valve, manually operated
6	1A	1	Cylinder
7		6	Hose line
8		2	Branch tee
9		1	Stop watch

Calculations

Let us assume the following data that required for the calculations:

Piston area, $A_{PN} = 200 \text{ mm}^2$

Piston annular area, $A_{PR} = 120 \text{ mm}^2$

Stroke length, $S = 200 \text{ mm}$

Pump output, $Q = 3.333 \times 10^4 \text{ mm}^3/\text{sec}$

Now,

$$\text{Area ratio, } \alpha = \frac{A_{PN}}{A_{PR}} = 1.667$$

$$\text{Advance-stroke speed, } V_{adv} = \frac{Q}{A_{PN}} = 166.665 \text{ mm/sec}$$

$$\text{Return stroke speed, } V_{ret} = \frac{Q}{A_{PR}} = 277.775 \text{ mm/sec}$$

$$\text{Advance-stroke time, } T_{adv} = \frac{S}{V_{adv}} = 1.2 \text{ sec}$$

$$\text{Return-stroke time, } T_{ret} = \frac{S}{V_{ret}} = 0.72 \text{ sec}$$

$$\text{Travel speed ratio, } \frac{V_{adv}}{V_{ret}} = 0.6$$

$$\text{Travel time ratio, } \frac{T_{adv}}{T_{ret}} = 1.667$$

Proposed hydraulic circuit and its operation

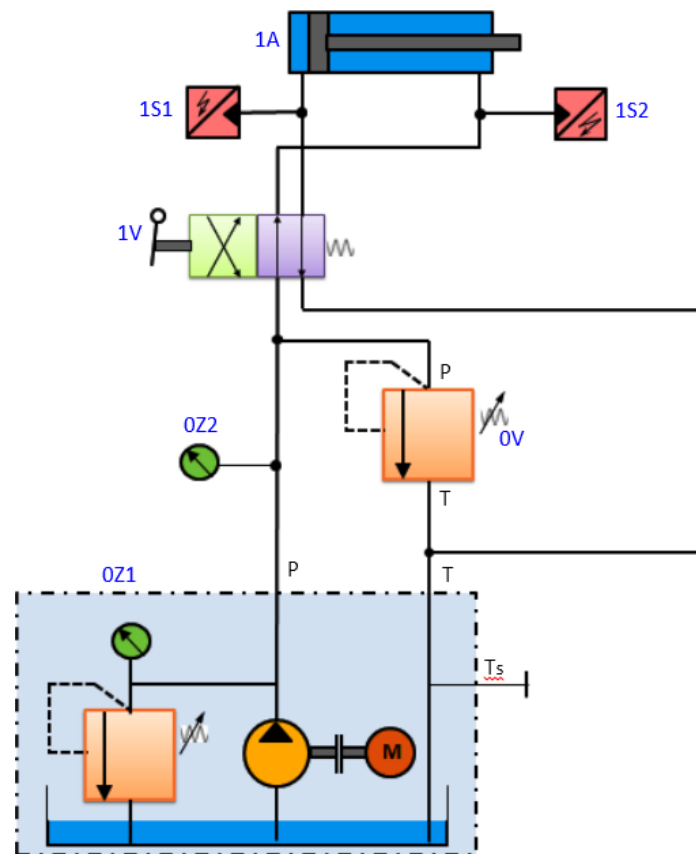


Figure 5.8.4 Hydraulic circuit for furnace door control

Figure 5.8.4 shows the hydraulic circuit for furnace door control. Once the circuit has been assembled and checked, the hydraulic power pack should be switched on and the system pressure set on the pressure relief valve 0V to a pre-set value. By operating the hand lever of valve 1V the opening and closing of the furnace can easily be carried out. When this 4/2-way valve is actuated, the piston rod of the cylinder will advance until the lever is released or the piston rod runs against the stop. When the lever is released, the piston rod will immediately return to its retracted end position. The hand lever can also be remotely operated by using suitable mechanism. Pressure sensors should be used to measure the travel and back pressures.