

ARYAN SCHOOL OF ENGINEERING & TECHNOLOGY

BARAKUDA, PANCHAGAON, BHUBANESWAR, KHORDHA-752050



LECTURE NOTE

SUBJECT NAME- UTILIZATION OF ELECTRICAL ENERGY & TRACTION

BRANCH – ELECTRICAL ENGINEERING

SEMESTER – 5TH SEM

ACADEMIC SESSION - 2022-23

PREPARED BY – SMITASHREE JENA

UNIT 1

Electric Drives

INTRODUCTION

Motor control is required in large number of industrial and domestic applications such as transportation systems, rolling mills, paper machines, textile mills, machine tools, fans, pumps, robots, and washing machines. Systems employed for motion control are called *drives* and may employ any of the prime movers. Drives employing electric motors are known as electric drives.

Nowadays, in electric power stations generating large amounts of electric energy for agriculture, industry, domestic needs, and electrified traction facilities and in driving all kinds of working machines, electric motor is essential, which is the predominant type of drive so the term electric drive being applied to it.

Electric drive becomes more popular because of its simplicity, reliability, cleanliness, easiness, and smooth control. Both AC and DC motors are used as electric drives; however, the AC system is preferred because:

- It is cheaper.
- It can be easily transmitted with low-line losses.
- It can be easy to maintain the voltage at consumer premises within prescribed limits.
- It is possible to increase or decrease the voltage without appreciable loss of power.

In spite of the advantages of AC motor, sometimes DC motor is used because:

- In some processes, such as electrochemical and battery charging, DC is the only type of power that is suitable.
- The speed control of DC motors is easy rather than AC; thus, for variable speed applications such as lift and Ward Leonard system, the DC motors are preferred.
- DC series motor is suited for traction work because of high starting torque.

BLOCK DIAGRAM OF ELECTRIC DRIVE

Source

1- ϕ and 3- ϕ , 50-Hz AC supplies are readily available in most locations. Very low power drives are generally fed from 1- ϕ source; however, the high power drives are powered from 3- ϕ source; some of the drives are powered from a battery

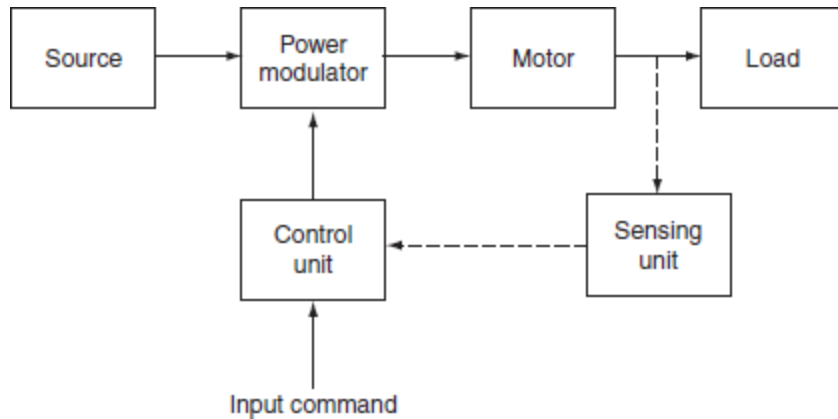

Fig. Block diagram of electric drive

Ex: Fork lifts trucks and milk vans.

Power modulator

Power modulator performs the following functions:

- It modulates flow of power from the source to the motor is impart speed–torque characteristics required by the load.
- It regulates source and motor currents within permissible values, such as starting, braking, and speed reversal conditions.
- Selects the mode of operation of motor, i.e., motoring or braking.
- Converts source energy in the form suitable to the motor.

Electrical motors

Motors commonly used in electric drives are DC motors, induction motors, synchronous motors, brushless DC motors, stepper motors, and switched reluctance motors, etc. In olden days, induction and synchronous motors were employed mainly for constant speed drives but not for variable speed drives, because of poor efficiency and are too expensive. But in nowadays, AC motors employed in variable speed drives due to the development of semiconductors employing SCRs, power transistors, IGBTs, and GTOs.

Load

It is usually a machinery, such as fans, pumps, robots, and washing machines, designed to perform a given task, usually load requirements, can be specified in terms of speed and torque demands.

Control unit

Control unit controls the function of power modulator. The nature of control unit for a particular drive depends on the type of power modulator used. When semiconductor converters are used, the control unit will consist of firing circuits. Microprocessors are also used when sophisticated control is required.

Sensing unit

Sensing unit consists of speed sensor or current sensor. The sensing of speed is required for the implementation of closed loop speed control schemes. Speed is usually sensed using tachometers coupled to the motor shaft. Current sensing is required for the implementation of current limit control.

Advantages of electric drives

There are a number of inherent advantages that the electric drive possesses over the other forms of conventional drives are:

- They have comparatively long life than the mechanical drive.
- It is cleaner, as there are no flue gases, etc.
- It is more economical.
- They have flexible control characteristics.
- There is no need to store fuel or transportation.
- It requires less maintenance.
- Do not pollute environment.
- It is the reliable source of drive.
- The electrical energy can be easily transmitted by using transmission lines over long distances.
- Available in wide range of torque, speed, and power.
- High efficiency.
- Electric braking system is much superior and economical.
- Smooth speed control is easy.
- They can be started instantly and can immediately be fully loaded.
- They can operate in all the quadrants of speed torque plane.
- Being compactness, they require less space.
- They can be controlled remotely.

Disadvantages of electric drives

The two inherent disadvantages of the electric drive system are:

- The non-availability of drive on the failure of electrical power supply.
- It cannot be employed in distant places where electric power supply is not available.

TYPES OF ELECTRIC DRIVES

Depending on the type of equipment used to run the electric motors in industrial purpose, they may be classified into three types. They are:

1. Group drives.
2. Individual drives.
3. Multi-motor drives.

Group drives

Electric drive that is used to drive one or more than two machines from line shaft through belts and pulleys is known as *group drive*. It is also sometimes called the *line shaft drive*. This drive is economical in the consideration of the cost of motor and control gear. A single motor of large capacity cost is less than the total cost of a number of small motors of the same total capacity. In switch over from non-electric drive to electric drive, the simplest way is to replace the engine by means of motor and retaining the rest of power transmission system.

Advantages

- The cost of installation is less. For example, if the power requirement of each machine is 10 HP and there are five machines in the group, then the cost of five motors will be more than one 50-HP motor.
- If it is operated at rated load, the efficiency and power factor of large group drive motor will be high.
- The maintenance cost of single large capacity motor is less than number of small capacity motors.
- It is used for the processes where the stoppage of one operation necessitates the stoppages of sequence of operations as in case of textile mills.
- It has overload capacity.

Disadvantage

Even though group drive has above advantages, it suffers from the following disadvantages.

- If there is any fault in the main motor, all the machines connected to the motor will fail to operate; thereby, paralyzing a part of industry until the fault is removed.
- It is not possible to install any machine at a distant place.
- The possibility of the installation of additional machines in an existing industry is limited.

- The level of noise produced at the work site is quite large.
- The speed control of different machines using belts and pulleys is difficult.
- The flexibility of layout is lost due to line shaft, belts, and pulleys.

Individual drive

In individual drive, a single electric motor is used to drive one individual machine. Such a drive is very common in most of the industries.

Advantages

- It is more clean and safety.
- Machines can be located at convenient places.
- If there is a fault in one motor, the output and operation of the other motors will not be effected.
- The continuity in the production of the industry is ensured to a higher degree.
- Individual drive is preferred for new factories, as it causes some saving in the cost.

Disadvantage

- Initial cost will be high.
- Power loss is high.

Multi-motor drive

In multi-motor drives, several separate motors are provided for operating different parts of the same machine.

Ex: In traveling cranes, three motors are used for hoisting, long travel, and cross-travel motions. Multi-motor drive is used in complicated metal cutting machine tools, rolling mills, paper making machines, etc.

CHOICE OF MOTORS

The selection of the driving motor for a given service depends upon the conditions under which it has to operate. Due to the universal adoption of electric drive, it has become necessary for the manufacturer to manufacture motors of various designs according to the suitability and the use in various designs according to the suitability and the use in various classes of industry. This has resulted into numerous types of motors. For this reason, the selection of motor itself has become an important and tedious process. The conditions under which an electric motor has to operate and the type of load it has to handle, determine its selection.

While selecting a motor, the following factors must be taken into consideration:

1. Cost:

1. initial cost and
2. running cost.

Electric characteristics:

0. starting characteristics,
1. running characteristics,
2. speed control characteristics, and
3. braking characteristics.

Mechanical characteristics:

0. type enclosure and bearings,
1. arrangement for the transmission of power,
2. noise, and
3. cooling.

Size and vetting of motors:

0. requirements for continuous, Intermittent, or variable load cycle and
1. overload capacity.

Type of drive:

0. the drive is for one or more machines and
1. the type of transmission through gears, belts, etc.

Nature of supply.

From the above, it is seen that a large number of factors are to be considered in making the choice of an electric motor for a given drive. The motor selected must fulfill all the necessary load requirements and at the same time, it should not be very costly if it has to be a commercial success. The factors motioned above will be individually discussed in the following sections to bring home to the reader the importance of each. While making the final choice of the motor, a satisfactory compromise may have to be made in some cases on account of the conflicting requirements.

CHARACTERISTICS OF DC MOTOR

The performance and, therefore, suitability of a DC motor are determined from its characteristics. The important characteristics of DC motor are:

1. *Torque vs. armature current characteristics (T vs. I_a):*
This characteristic curve gives relation between torque developed in the armature (*T*) and armature current (*I_a*). This is also known as *electrical characteristic*.
2. *Speed vs. armature current characteristics (N vs. I_a):*
This characteristic curve gives relation between speed (*N*) and armature current (*I_a*). This is also known as *speed characteristics*.
3. *Output (HP) vs. armature current characteristics (HP vs. I_a):*
The horse power of the motor is dependent on the shaft torque, so its characteristics follows *shaft torque characteristic*.
4. *Speed vs. characteristics (N vs. T):*

This characteristic gives relation between speed (*N*) and torque (*T*) developed in the armature. This curve may be derived from the two characteristics mentioned in characteristics (i) and (ii) above.

Characteristics (i), (ii), and (iii) are called *starting characteristics*, and (iv) is known as *running characteristics*.

While discussing motor characteristics, the following relations should always be kept in mind.

$$T \propto \phi I_a \quad \text{and} \quad N \propto \frac{E_b}{\phi},$$

where *T_a* is the torque developed in the armature in N-m, *I_a* is the armature current in ampere, *E_b* is the back emf in volts, and ϕ is the flux in weber.

Characteristics of shunt motor

The field winding connected across the armature terminals called as *shunt motor* as shown in Fig. Rated voltage is applied across the field and armature terminals.

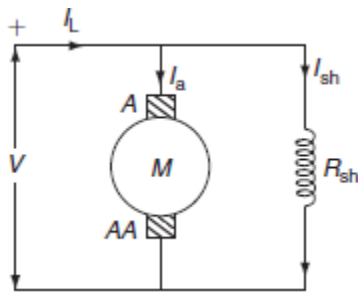

Fig. DC shunt motor

Starting characteristics

The study of starting characteristics of a motor is essential to know the starting torque necessary to accelerate the motor from standstill position is also to require to overcome the static friction and the standstill load or, to provide load torque.

Torque vs. armature current (T Vs I_a)

In the expression for the torque of a DC motor, torque is directly proportional to the product of flux per pole (ϕ) and armature current (I_a):

$$\therefore T \propto \phi I_a$$

Since, in case of a DC shunt motor, the flux per pole (ϕ) is considered to be constant.

$$\therefore T \propto I_a.$$

So, the torque is proportional to armature current and is practically a straight line passing through the origin as shown in [Fig. 1.3](#).

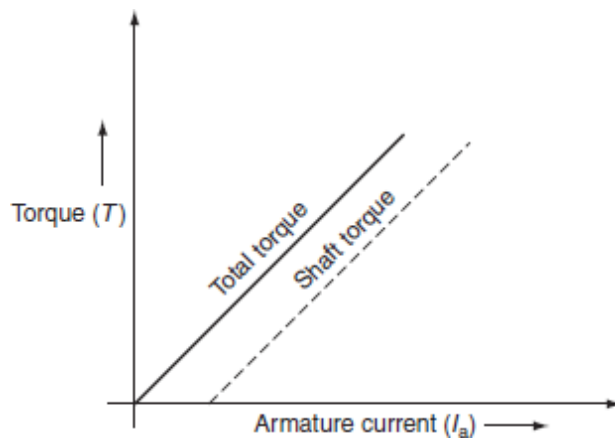

Fig. 1.3 Torque vs. armature current characteristics

To generate high starting torque, this type of motor requires a large value of armature current at starting. This may damage the motor, hence DC shunt motors can develop moderate starting torque and hence suitable for such applications where starting torque requirement is moderate.

Speed vs. armature current (N Vs I_a)

In shunt motor, the applied voltage ‘ V ’ is kept constant, the field current will remain constant, and hence the flux will have maximum value on no load due to the armature reaction; if load on the motor increases, the flux will be slightly decrease. By neglecting the armature reaction, the flux is almost constant.

From the speed equation of DC shunt motor:

$$N \propto \frac{E_b}{\phi},$$

where $E_b = V - I_a R_a$

$$\therefore N \propto \frac{V - I_a R_a}{\phi}.$$

Since, for DC shunt motor, the flux per pole is considered to be constant.

$$\therefore N \propto V - I_a R_a.$$

So, as the load on the motor increases, the armature current increases and hence $I_a R_a$ drop also increases. For constant supply, the voltage ($V - I_a R_a$) decreases and hence the speed reduces.

Hence, as armature current increases, the speed of the DC motor decreases. The variation of speed with armature current is shown in Fig. 1.4.

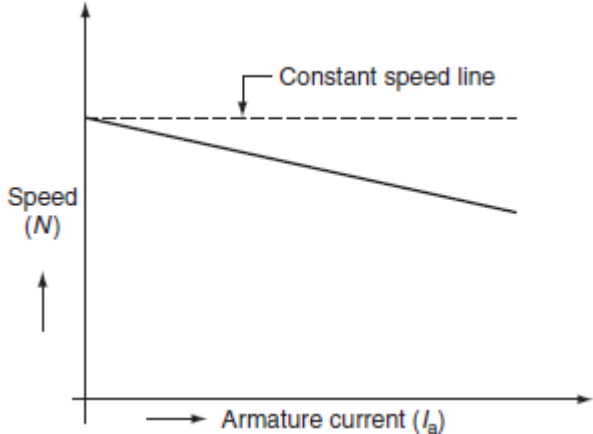

Fig. 1.4 Speed vs. armature current characteristics

Output vs. armature current

The output of the motor is dependent on the shaft torque. If the armature current increases, the output of the motor gradually increases. The variation of output with the armature current is shown in Fig. 1.5.

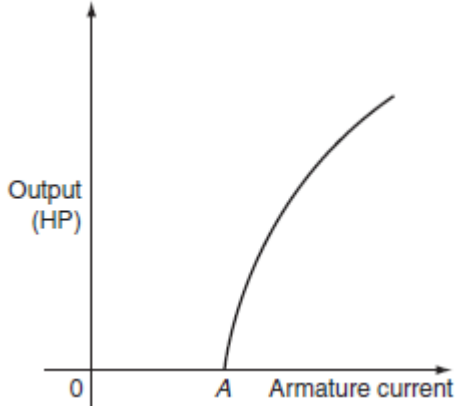

Fig. 1.5 Armature current and HP characteristics

Running characteristics

Speed-torque characteristics (N vs. T)

These characteristics can be derived from its starting characteristics of (i) and (ii). During the steady-state operation of the motor, the voltage equation of the armature circuit is given by:

$$V = E_b + I_a R_a,$$

where V is the applied voltage, E_b is the back emf of motor, I_a is the armature current, and R_a is the armature resistance.

The back emf of motor can be expressed as:

$$E_b \propto \phi N$$

$$\therefore E_b = K \phi N,$$

where K is the constant, $N = \frac{E_b}{K\phi}$.

Substituting E_b from Equation (8.3) in above equation:

$$\text{Speed, } N = \frac{V - I_a R_a}{K\phi}.$$

The torque of the motor is directly proportional to product of flux and armature current.

$$\begin{aligned} \therefore T &\propto \phi I_a \\ &= K \phi I_a \end{aligned}$$

$$I_a = \frac{T}{K\phi}$$

Substitute Equation (8.6) in Equation (8.4), we get:

$$N = \frac{V}{K\phi} - \frac{T}{(K\phi)^2} \times R_a.$$

Since, the shunt motor flux is constant, the speed of the motor is:

$$N = \frac{V}{K_1} - \frac{T}{K_1^2} R_a,$$

where $K_1 = K\phi$.

When V and R_a are kept constant, the speed torque characteristic is a *straight line*.

If the load on the motor increases, thus the torque increases and hence the speed of the motor decreases. The characteristic curve can be drawn from the

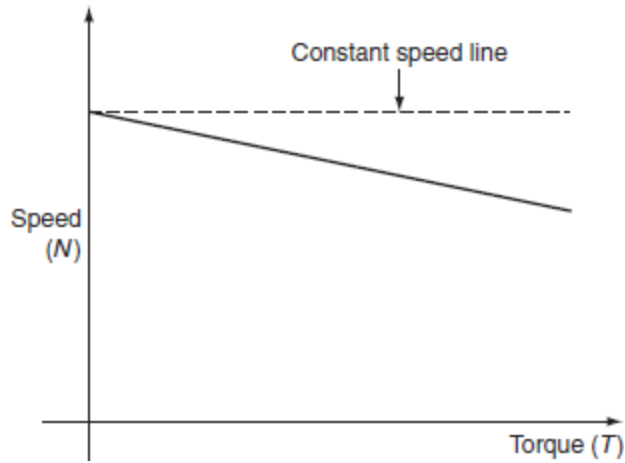

Fig. 1.6 Speed and torque characteristics

Characteristics of DC series motor

In case of series motor, the field windings are connected in series with armature terminals as shown in Fig. 1.7. Since, the field winding is connected in series with the armature winding, the load current (I_L) is equals to the armature current (I_a) or the series field current (I_{se}).

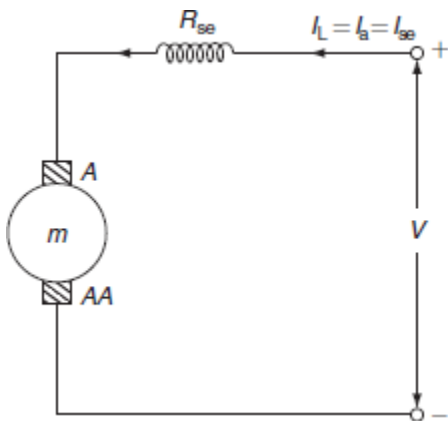

Fig. 1.7 DC series motor

$$\therefore I_L = I_a = I_{se}.$$

Starting characteristics

Torque vs. armature current (T Vs I_a)

In case of DC motors, torque is directly proportional to the product of flux per pole (ϕ) and armature current (I_a).

$$\therefore T \propto \phi I_a.$$

Up to the saturation point, the flux is proportional to the field current and hence the armature current:

$$\therefore \phi \propto I_{se} \propto I_a.$$

Therefore, the torque is proportional to the square of the armature current.

$$\therefore T \propto I_a^2 (\because I_a = I_{se}).$$

Hence, the curve drawn in Fig. 8.8; the torque and the armature currents are parabolas, up to saturation point. After saturation, the flux (ϕ) is almost independent of the excitation current and so the torque is proportional to the armature current, i.e., $T \propto I_a$. Hence the characteristics become a straight line. The variation of torque with the armature current is shown in Fig. 8.8.

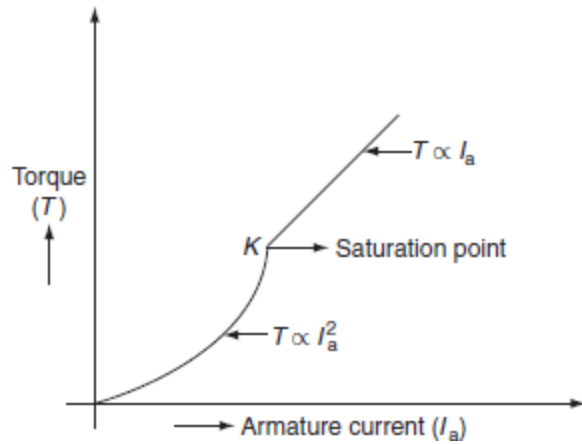

Fig. 1.8 Torque and armature current

Speed vs. armature current

From the speed equation of DC series motor, the speed is directly proportional to the back emf and is inversely proportional to flux:

$$\text{i.e., } N \propto \frac{E_b}{\phi}$$

where $E_b = V - I_a R_{se}$.

When the armature current increases, the voltage drop in the armature resistance and the field resistance increases, but under the normal conditions, the voltage drop is small and it is negligible. Hence, $V = E_b$ and it is constant:

$$\therefore N \propto \frac{1}{\phi} \propto \frac{1}{I_a}$$

$$\therefore N \propto \frac{1}{I}$$

This relation shows the variation of speed with the armature current and it will be *arectangular hyperbola*, which is shown in Fig. 1.9.

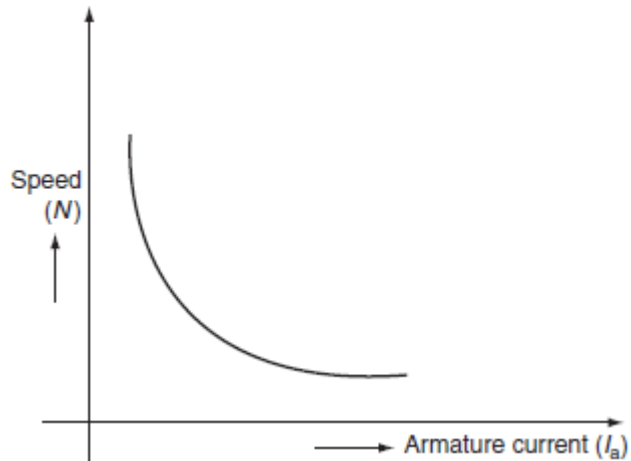

Fig. 1.9 Speed and armature current

Running characteristics

Speed-torque characteristics

These characteristics can be derived its starting characteristics. It is also known as *asmechanical characteristic*.

In case of series motors:

$$T \propto \phi I_a \propto I_a^2$$

and $N \propto \frac{1}{I_a}$.

As the torque of a DC machine is directly proportional to armature current and flux, the speed will be inversely proportional to the square root of the torque, i.e., from the above two relations:

$$N \propto \frac{1}{\sqrt{T}}$$

But at higher loads, the flux becomes saturated and the torque will be proportional to armature current, so the speed can be represented as:

$$N \propto \frac{1}{T}$$

The speed–torque characteristics of a DC series motor is shown in Fig. 1.10.

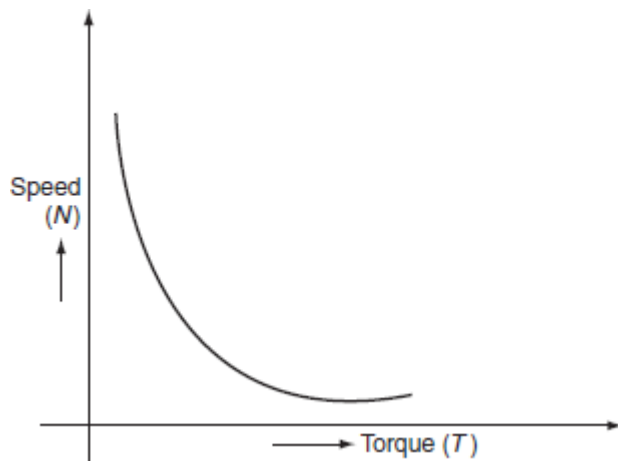

Fig. 1.10 Speed–torque characteristics

Hence, the series motors are best suited for services where the motor is directly coupled to the load such as whose speed falls with the increase in load torque.

Characteristics of DC compound wound motors

Compound motors have both series. If the series field excitation aids with the shunt excitation, then the motor is said to be *cumulatively compounded*. If the series field opposes the shunt field excitation, it is known as *differential compound motor*.

The characteristics of such motors lie in between shunt and series motors.

Cumulative-compound motor

Since, the series field aids with the shunt field winding, the flux is increased, as load is applied to the motor, and due to this reason, the motor speed slightly decreases. Such machines are used where series characteristics are required. Due to the shunt field, the winding speed will not become excessively high, but due to the series field winding, it will be able to take heavy loads.

Compound wound motors have the greatest application with loads that require high starting torques or pulsating load.

Differential-compound motors

In this motor, the series field opposes the shunt field and the flux is decreased, as load is applied to the motor. This results in the motor speed that is almost constant or even increasing with increase in load.

The speed-armature current and the torque-armature current characteristics of both the cumulative and the differential compound motors are shown in [Figs. 1.11](#) and [1.12](#).

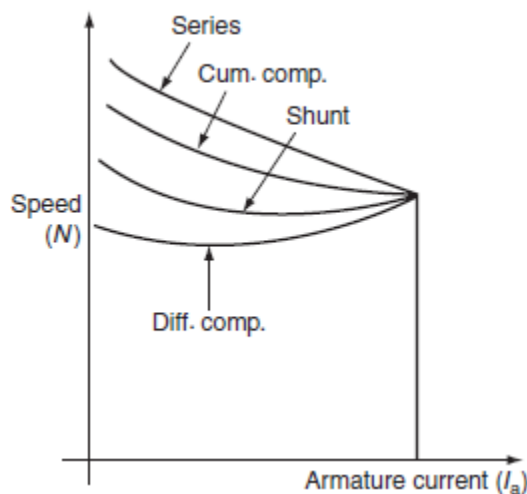

Fig. 1.11 Speed and armature current characteristics

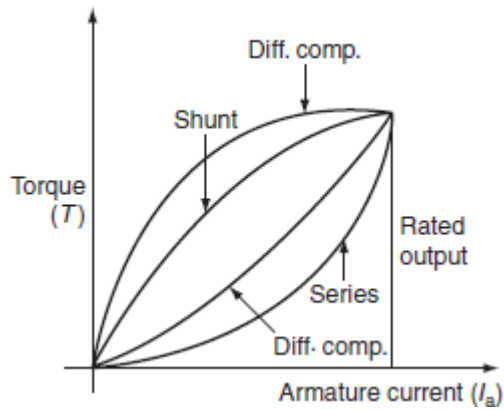

Fig. 1.12 Torque and armature current characteristics

THREE-PHASE INDUCTION MOTOR

Three-phase induction motors are simple in design, rugged in construction with the absence of commutator, and reliable in service. Besides this, they have low initial cost, simple maintenance, easy operation, and simple control gear for starting and speed control.

The speed–torque characteristics of the induction motor are quite important in the selection of the induction motor drive. These characteristics can be effectively determined by means of the equivalent circuit of the induction motor. The simplified equivalent circuit of induction motor is shown in Fig. 1.13.

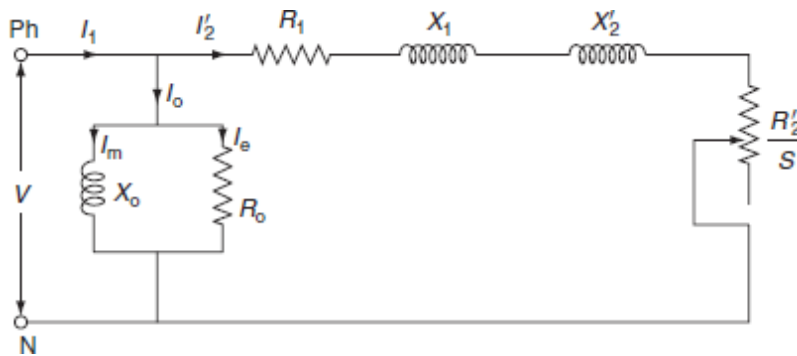

Fig. 1.13 Equivalent circuit of induction motor

In Fig. 1.13, V is the applied voltage per phase, R_1 and X_1 are the stator resistance and leakage reactance per phase, R_2' and X_2' are the rotor resistance and leakage reactance per phase, R_0 and X_0 are the resistance and reactance per phase of the magnetizing branch, and I_2' is the rotor current per phase.

From the equivalent circuit of induction motor, as shown in Fig. 1.13, the rotor current referred to the stator is given by:

$$I_2' = \frac{V}{\sqrt{\left(R_1 + \frac{R_2'}{S}\right)^2 + (X_1 + X_2')^2}}$$

If the induction motor is rotating at slip is then:

Induced emf of rotor = SE_2 .

Rotor resistance = R_2 .

Rotor reactance = SX_2 .

Rotor current /phase, $I_2 = \frac{SE_2}{\sqrt{R_2^2 + (SX_2)^2}}$.

8.6.1 Torque equation

The torque produced in the induction motor is mainly depends on the magnitude of rotor current, the power factor of the rotor circuit, and the part of rotating magnetic field that interacts with the rotor.

$$\therefore T \propto E_2 I_2 \cos \phi_2.$$

Substituting the values of I_2 and $\cos \phi_2$ in Equation (8.13):

$$T \propto E_2 \times \frac{SE_2}{\sqrt{R_2^2 + (SX_2)^2}} \times \frac{R_2}{\sqrt{R_2^2 + (SX_2)^2}}$$

$$\therefore T \propto \frac{SE_2^2 R_2}{R_2^2 + (SX_2)^2}$$

$$T = \frac{KSE_2^2 R_2}{R_2^2 + (SX_2)^2},$$

where 'K' is proportionality constant and is proved to be $\frac{3}{2\pi N_s}$ for the three-phase induction motor.

$$\therefore T = \frac{3}{2\pi N_s} \frac{SE_2^2 R_2}{R_2^2 + (SX_2)^2}, \quad (8)$$

where N_s is synchronous speed in rps at standstill slip $S = 1$; therefore, the expression for starting torque may be obtained by putting $S = 1$

$$\therefore T_{st} = \frac{KE_2^2 R_2}{R_2^2 + X_2^2}.$$

Condition for maximum torque

The torque developed by the motor under running condition mainly depends on slip at which motor is running.

Therefore, the torque will be maximum when:

$$\frac{dT}{dS} = 0; \quad \text{where } T = \frac{KSE_2^2 R_2}{R_2^2 + (SX_2)^2}.$$

By differentiating torque w.r.t. 'S' we get:

$$\frac{dT}{dS} = \frac{(KSE_2^2 R_2) \frac{d}{dS}(R_2^2 + S^2 X_2^2) - (R_2^2 + S^2 X_2^2) \frac{d}{dS}(KSE_2^2 R_2)}{(R_2^2 + S^2 X_2^2)^2}$$

$$\therefore KS_m E_2^2 (2S_m X_2^2) - (R_2^2 + S_m^2 X_2^2) = 0$$

$$2S_m^2 X_2^2 - (R_2^2 + S_m^2 X_2^2) = 0$$

$$R_2 = S_m X_2$$

$$S_m = \frac{R_2}{X_2} \tag{8.17}$$

Equation (8.17) reveals that the slip 'S_m' at which maximum torque will be developed by the induction motor.

From Eq. (8.14), the maximum torque corresponding to slip $S_m = R_2/X_2$ is given by:

$$T_{\max} = \frac{K \times \frac{R_2}{X_2} \times R_2 \times E_2^2}{R_2^2 + \frac{R_2^2}{X_2^2} \times X_2^2}$$

$$= \frac{KE_2^2}{2X_2} \tag{8.18}$$

Torque ratios

The performance of motor is estimated in terms of the ratios of different torques such as full-load, starting, and maximum torques.

Ratio of full-load torque to maximum torque

Let,

S_f = full-load slip of the motor

$$S_m = \text{slip corresponding to maximum torque} = \frac{R_2}{X_2}.$$

According to the torque, the equation of motor is:

$$\text{Full-load torque } T_{fl} \propto \frac{S_f E_2^2 R_2}{R_2^2 + (S_f X_2)^2}.$$

$$\text{Maximum torque } T_m \propto \frac{S_m E_2^2 R_2}{R_2^2 + (S_m X_2)^2}.$$

$$\begin{aligned} \therefore \frac{T_{FL}}{T_m} &= \left[\frac{S_f E_2^2 R_2}{R_2^2 + (S_f X_2)^2} \right] \left(\frac{R_2^2 + (S_m X_2)^2}{S_m E_2^2 R_2} \right) \\ &= \frac{S_f \left[\left(\frac{R_2}{X_2} \right)^2 + S_m^2 \right]}{S_m \left[\left(\frac{R_2}{X_2} \right)^2 + S_f^2 \right]}. \end{aligned}$$

$$\text{We know that } \frac{R_2}{X_2} = S_m$$

$$\begin{aligned} \therefore \frac{T_{FL}}{T_m} &= \frac{S_f \left[\frac{2S_m^2}{S_f^2 + S_m^2} \right]}{S_m \left[\frac{2S_m^2}{S_f^2 + S_m^2} \right]} \\ &= \frac{2S_f S_m}{S_f^2 + S_m^2}. \end{aligned}$$

Ratio of starting torque to maximum torque

From Equations (8.16) and (8.18):

$$\begin{aligned} \frac{T_{st}}{T_m} &= \frac{KE_2^2 R_2}{R_2^2 + X_2^2} \times \frac{2X_2}{KE_2^2} \\ &= \frac{2(R_2/X_2)}{(R_2/X_2)^2 + 1} \\ &= \frac{2S_m}{S_m^2 + 1}. \end{aligned}$$

Torque–speed and torque–slip characteristics

The torque–speed and torque–slip characteristics are shown in Fig. 8.14 (a) and (b). According to the torque equation of motor:

$$T \propto \frac{SE_2^2 R_2}{R_2^2 + (SX_2)^2}$$

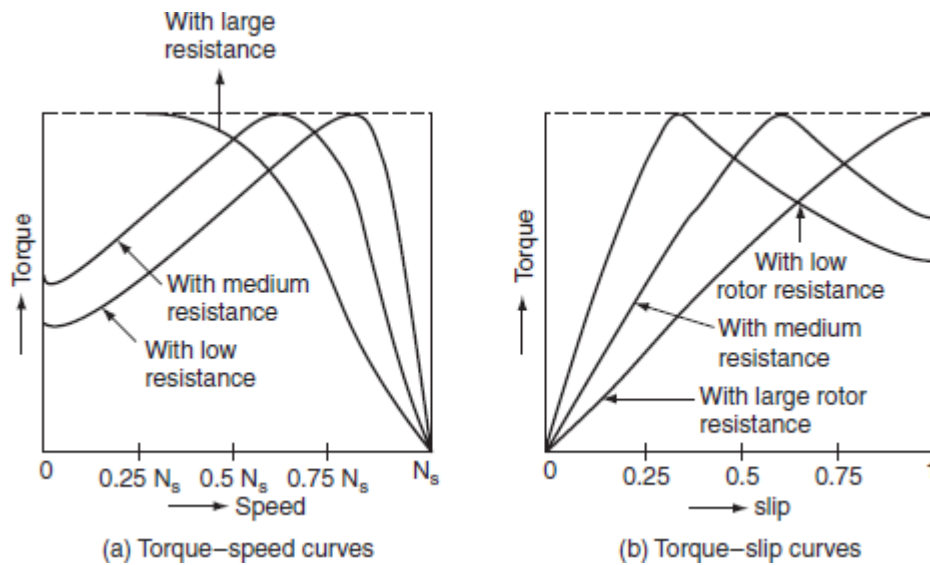

Fig. 8.14 (a) Torque–speed characteristics and (b) torque–slip characteristics

But for constant supply voltage, E_2 is also constant:

$$\text{i.e., } T \propto \frac{SR_2}{R_2^2 + (SX_2)^2}$$

From the above expression, it is evident that, when torque is zero, slip $S = 0$ in low-slip region, slip is very very small, so that (SX_2) is so small compared to R_2 ; hence, it can be neglected.

$$T \propto \frac{SR_2}{R_2^2} \propto S.$$

Therefore, torque T is proportional to slip 'S' if rotor resistance R_2 is constant. That is speeds nearer to synchronous speeds, the torque-speed, and torque-slip curves are approximately straight lines.

In high-slip region, the slip value approaches to unity. Here, it can be assumed that R_2^2 is very very small as compared to $(SX_2)^2$; hence, it can be neglected.

$$T \propto \frac{SR_2}{S^2 X_2^2}.$$

When slip increases, the torque increases to its maximum value when $S = R_2/X_2$. The maximum torque is also known as pullout or breakdown torque. Beyond this, if slip further increases torque is inversely proportional to slip if R_2 and X_2 are constant.

This means that the torque-speed and the torque-slip curves are approximately straight lines. Figure 8.14 (a) and (b) shows the torque speed and the torque-slip curves for the different values of rotor resistance.

Example 1.1: A 3- ϕ induction motor has a ratio of maximum torque to full-load torque as 2:1. Determine the ratio of actual starting torque to full-load torque for $Y - \Delta$ starting. Given $R_2 = 0.2 \Omega$ and $X_2 = 2\Omega$.

Solution:

Given data:

$$\frac{T_m}{T_f} = 2.$$

$$R_2 = 0.2\Omega.$$

$$X_2 = 2\Omega.$$

The slip at maximum torque is $S_m = \frac{R_2}{X_2} = \frac{0.2}{2} = 0.1$.

We know that $\frac{T_f}{T_m} = \frac{2S_f S_m}{S_f^2 + S_m^2}$

$$\frac{1}{2} = \frac{2S_f \times 0.1}{S_f^2 + (0.1)^2}$$

$$S_f^2 + (0.1)^2 = 0.4 S_f$$

$$S_f^2 - 0.4S_f + 0.01 = 0$$

$$S_f = \frac{0.4 \pm \sqrt{(0.4)^2 - 4 \times 1 \times 0.01}}{2 \times 1}$$

$$= \frac{0.4 \pm 0.346}{2}$$

$$= 0.054 \quad (\text{taking small value}).$$

∴ Full-load current per phase:

$$I_f = \frac{S_f E_2}{\sqrt{R_2^2 + (S_f X_2)^2}}$$

Short-circuit rotor current per phase:

$$I_{sc} = \frac{E_2}{\sqrt{R_2^2 + X_2^2}}$$

$$\therefore \frac{I_{sc}}{I_f} = \frac{\sqrt{R_2^2 + (S_f X_2)^2}}{S_f (\sqrt{R_2^2 + X_2^2})}$$

$$= \frac{\sqrt{(0.2)^2 + (0.054 \times 2)^2}}{0.054 \times \sqrt{(0.2)^2 + 2^2}} = \frac{0.227}{0.1085} = 2.091.$$

∴ Starting torque with star–delta starter:

$$T_{st} = \frac{1}{3} T_f \left(\frac{I_{sc}}{I_f} \right)^2 \times S_f$$

$$T_{st} = \frac{1}{3} \times T_f (2.091)^2 \times 0.054$$

$$\frac{T_{st}}{T_f} = 0.078.$$

Example 1.2: The supply voltage to a cage rotor motor is 70% instead of 100%. Determine the reduction in starting torque and starting current.

Solution:

Let ' I_{sc} ' be the starting current with normal voltage.

The starting current with 70% of supply voltage = $0.7 I_{sc}$.

The reduction in the starting current = $\frac{I_{sc} - 0.7I_{sc}}{I_{sc}} \times 100 = 30\%$.

$$\begin{aligned} \text{The starting torque with normal} &= T_f \left(\frac{I_{sc}}{I_f} \right)^2 S_f \\ &= T_f \left(\frac{0.7I_{sc}}{I_f} \right)^2 S_f \\ &= 49 \text{ times the starting torque,} \end{aligned}$$

where T_f , I_f , S_f , and I_{sc} are the full-load torque, full-load current, full-load slip, and short-circuit current, respectively.

$$\begin{aligned} \text{Reduction in starting torque} &= (1 - 49) \times 100 \\ &= 51\%. \end{aligned}$$

Example: Determine the ratio of actual starting torque to full-load torque for star-delta starting. If a 3- ϕ induction motor has a ratio of maximum torque to full-load torque as 3:1 and the resistance and the reactance are 0.4 Ω and 5 Ω , respectively.

Solution:

The ratio of maximum torque to full-load torque:

$$\frac{T_{\max}}{T_f} = \frac{R_2^2 + S_f^2 X_2^2}{2S_f R_2 X_2}$$

$$3 = \frac{(0.4)^2 + (5)^2 S_f^2}{2S_f \times 0.4 \times 5}$$

$$12S_f = 0.16 + 25S_f^2$$

$$25S_f^2 - 12S_f + 0.16 = 0$$

$S_f = 0.013$, neglecting higher values.

$$\text{Full-load rotor current/phase} = \frac{S_f E_2}{\sqrt{R_2^2 + S_f^2 X_2^2}} = I_f.$$

$$\text{Short-circuit rotor current/phase, } I_{sc} = \frac{E_2}{\sqrt{R_2^2 + X_2^2}}$$

$$\frac{I_{sc}}{I_f} = \frac{\sqrt{R_2^2 + S_f^2 X_2^2}}{S_f \sqrt{R_2^2 + X_2^2}}$$

$$= \frac{\sqrt{(0.4)^2 + (0.013)^2 \times (5)^2}}{(0.013) \sqrt{(0.4)^2 + (5)^2}}$$

$$= 6.23.$$

Starting torque with star–delta starter:

$$\begin{aligned}
 T_{st} &= \frac{1}{3} T_f \left(\frac{I_{sc}}{I_f} \right)^2 S_f \\
 &= \frac{1}{3} \times T_f \times (6.23)^2 \times 0.013 \\
 &= 0.168 T_f
 \end{aligned}$$

$$\begin{aligned}
 \frac{T_{st}}{T_f} &= K^2 \left(\frac{I_{sc}}{I_f} \right)^2 \times S_f \\
 &= (0.6124)^2 \left(\frac{266.7}{72.16} \right)^2 \times 0.06 \\
 &= 0.306.
 \end{aligned}$$

Example: Determine the new value of stator current if a 3- ϕ , 440-V and 1,200-rpm slip ring induction motor is operating with 3% slip and taking a stator current of 50-A speed of the motor is reduced at constant torque to 600 rpm using stator voltage control.

Solution:

Slip at the reduced speed:

$$\begin{aligned}
 S^1 &= \frac{N_s - N^1}{N_s} = \frac{1,200 - 600}{1,200} \\
 &= 0.5.
 \end{aligned}$$

Torque developed by the induction motor $T \propto SV^2$ for the constant torque:

$$\begin{aligned}
 V &\propto \sqrt{\frac{1}{S}} \\
 V^1 &= V \sqrt{\frac{S}{S^1}} = 440 \times \sqrt{\frac{0.03}{0.5}} \\
 &= 107.77 \text{ V.}
 \end{aligned}$$

Stator current $I_1 \propto SV$.

The new stator current:

$$\begin{aligned} I_1^1 &= I_1 \times \frac{S^1 V^1}{SV} \\ &= \frac{50 \times 0.5 \times 107.77}{0.03 \times 440} \\ &= 204.1 \text{ A.} \end{aligned}$$

Example: A 9.5-kW, 240-V, three-phase, star-connected, 50-Hz, and four-pole squirrel cage induction has its full-load internal torque at a slip of 0.05. The parameters of the motor are

$$R_1 = 0.4\Omega/\text{phase}, \quad R_2 = 0.3\Omega/\text{phase}$$

$$X_1 = X_2 = 0.5\Omega/\text{phase}, \quad X_m = 16\Omega/\text{phase}.$$

Assume that the shunt branch is connected across the supply terminals. Determine (a) maximum internal torque at rated voltage and frequency, (b) slip at maximum torque, and (c) internal starting torque at rated, voltage, and frequency.

Solution:

$$\text{Phase voltage, } V = \frac{240}{\sqrt{3}} = 138.56 \text{ V.}$$

At maximum torque:

$$\text{Maximum slip } S_{\max} = \frac{R_2}{X_2} = \frac{0.3}{0.5} = 0.6.$$

At maximum slip, the equivalent impedance of the motor is:

$$Z = \left(R_1 + \frac{R_2}{S} \right) + j(X_1 + X_2)$$

$$= \left(0.4 + \frac{0.3}{0.6} \right) + j(0.5 + 0.5)$$

$$= 0.9 + 1j = 1.3456148 \Omega.$$

$$\begin{aligned} \text{Rotor current per phase, } I_2 &= \frac{E_2}{Z} = \frac{138.56}{1.345\angle 48} \\ &= 103 \text{ A.} \end{aligned}$$

$$\begin{aligned} \text{Rotor copper losses} &= 3I_2^2 R_2 \\ &= 3 \times (103)^2 \times 0.3 \\ &= 9,548.1 \text{ W.} \end{aligned}$$

$$\begin{aligned} \text{The power input to rotor } P_2 &= \frac{\text{rotor copper loss}}{S_{\max}} \\ &= \frac{9548.1}{0.6} \\ &= 1,5913.5 \text{ synchronous W.} \end{aligned}$$

$$\text{Synchronous speed } N_s = \frac{120f}{P} = \frac{120 \times 50}{4} = 1,500 \text{ rpm.}$$

$$\begin{aligned} \text{Maximum torque } T &= \frac{9.55 \times P_2}{N_s} = \frac{9.55 \times 15,913.5}{1,500} \\ &= 101.31 \text{ N-m.} \end{aligned}$$

At standstill:

At standstill, the slip $S = 1.0$.

$$\begin{aligned} \text{Equivalent motor impedance, } Z &= (R_1 + R_2) + j(X_1 + X_2) \\ &= (0.3 + 0.4) + j(0.5 + 0.5) \\ &= 0.7 + j1 \\ &= 1.22 \angle 55\Omega. \end{aligned}$$

$$\text{Rotor current } I_2 = \frac{E_2}{Z} = \frac{138.56}{1.22} = 113.57 \text{ A.}$$

Power input to rotor $P_2 =$ total rotor copper losses

$$= 3 \times (113.57)^2 \times (0.3)$$

$$= 11,608.33 \text{ synchronous W.}$$

$$\begin{aligned} \text{Starting torque } T_{st} &= \frac{9.55 \times P_2}{N_s} \\ &= \frac{9.55 \times 11,608.33}{1,500} \\ &= 73.9 \text{ N-m.} \end{aligned}$$

Example: A 30-HP, six-pole, 50-Hz, and three-phase induction motor has stator/rotor phase voltage ratio of 7/5. The stator and rotor impedances per phase are $(0.35 + j0.65) \Omega$ and $(0.15 + j0.65) \Omega$, respectively. Find the starting torque exerted by the motor when an external resistance of 1.5Ω is inserted in each phase; the motor being started directly on the 440-V supply system. Assume Y/Y connection.

Solution:

$$\text{Supply voltage per phase } V = \frac{440}{\sqrt{3}} = 254 \text{ V.}$$

Rotor to stator phase voltage ration $K = 5/7 = 0.714$.

Equivalent resistance of motor as referred to rotor:

$$\begin{aligned} R_{02} &= R_2 + K_1^2 R_1 \\ &= (0.15) + (0.714)^2 (0.35) \\ &= 0.328 \Omega. \end{aligned}$$

Similarly, the equivalent reactance referred to rotor:

$$\begin{aligned}
X_{02} &= X_2 + K^2 X_1 \\
&= 0.65 + (0.714)^2 (0.65) \\
&= 0.98 \Omega.
\end{aligned}$$

When the external resistance is inserted then, the equivalent motor impedance referred to rotor is:

$$\begin{aligned}
Z &= \sqrt{(R_{02} + 1.5)^2 + X_{02}^2} \\
&= \sqrt{(328 + 1.5)^2 + (0.98)^2} \\
&= 2 \Omega.
\end{aligned}$$

At standstill, the induced emf in the rotor:

$$\begin{aligned}
E_2 &= V_1 \times K \\
&= 254.714 \\
&= 181.356 \text{ V}.
\end{aligned}$$

$$\text{Rotor current } R_2 = \frac{E_2}{Z} = \frac{181.356}{2}.$$

$$\begin{aligned}
\text{The rotor copper losses} &= 3I_2^2 R_2 \\
&= 3 \times 90.67^2 \times (0.15) \\
&= 3,699.47 \text{ W}.
\end{aligned}$$

At standstill, rotor power input:

$$P_2 = 3,699.47 \text{ W } (\because \text{ slip } S = 1).$$

$$\text{Synchronous speed } N_s = \frac{120f}{P} = \frac{120 \times 50}{6} = 1,000 \text{ rpm.}$$

$$\begin{aligned} \text{Starting torque } T_{st} &= \frac{9.55 \times 3699.47}{1,000} \\ &= 35.32 \text{ N-m.} \end{aligned}$$

Example: For a three-phase induction motor, maximum torque is thrice the full-load torque and starting torque is 1.9 times the full-load torque. In order to get a full-load slip of 6%, calculate the percentage reduction in rotor circuit resistance neglect stator impedance.

Solution:

The ratio of starting torque to maximum torque is given by:

$$\frac{T_{st}}{T_m} = \frac{2}{\frac{S_m}{1} + \frac{1}{S_m}}$$

$$\frac{1.9T_{fl}}{3T_{fl}} = \frac{2}{\frac{S_{m1}}{1} + \frac{1}{S_{m1}}}$$

$$0.64 = \frac{2}{S_{m1} + \frac{1}{S_{m1}}}$$

$$S_{m1}^2 - 3.125S_{m1} + 1 = 0$$

$$S_{m1} = 0.362 \text{ neglecting higher values.}$$

$$\text{Maximum slip } S_{m1} = \frac{R_2}{X_2}$$

$$\frac{R_2}{X_2} = 0.362$$

$$R_2 = 0.362 X_2.$$

For a full-load slip of 0.06, the ratio of full-load torque to maximum torque is given by:

$$\frac{T_f}{T_m} = \frac{2}{\frac{S_{m2}}{0.06} + \frac{0.06}{S_{m2}}}$$

$$\frac{1}{3} = \frac{2}{\frac{S_{m2}}{0.06} + \frac{0.06}{S_{m2}}}$$

$$S_{m2}^2 - 0.36S_{m2} + 0.0036 = 0$$

$$S_{m2} = 0.35$$

$$= \frac{R_2^1}{X_2}$$

$$0.35 = \frac{R_2^1}{X_2}$$

$$R_2^1 = 0.35X_2.$$

$$\begin{aligned} \therefore \text{The reduction in rotor circuit resistance} &= 0.362X_2 - 0.35X_2 \\ &= 0.012X_2. \end{aligned}$$

$$\begin{aligned} \therefore \text{The percentage reduction in rotor circuit resistance} &= \frac{0.362X_2 - 0.35X_2}{0.362X_2} \times 100 \\ &= \frac{0.012X_2}{0.362X_2} \times 100 \\ &= 3.315\%. \end{aligned}$$

Example: The rotor of a three-phase induction motor has 0.05-Ω resistance per phase and 0.3-standstill reactance per phase. What external resistance is required in the rotor circuit in order to get half of the maximum torque at starting? Neglect stator impedance by what percentage will this external resistance change the current and power factor at starting?

Solution:

The ratio of starting torque to the maximum torque is given by:

$$\frac{T_{st}}{T_m} = \frac{1/2 T_m}{T_m} = \frac{2}{\frac{S_m}{1} + \frac{1}{S_m}}$$

$$S_m^2 - 4S_m + 1 = 0$$

$$S_m = 0.27 \text{ neglecting higher values.}$$

We know that:

$$S_m = \frac{R_2^1}{X_2}$$

$$\begin{aligned} R_2^1 &= 0.27 \times 0.3 \\ &= 0.081 \Omega. \end{aligned}$$

$$\begin{aligned} \text{The external resistance inserted in the rotor circuit} &= R_2^1 - R_2 \\ &= 0.081 - 0.05 \\ &= 0.031 \Omega. \end{aligned}$$

Without external resistance:

$$\begin{aligned} \text{Starting current } I_{st} &= \frac{E_2}{\sqrt{R_2^2 + X_2^2}} \\ &= 3.28 E_2. \end{aligned}$$

$$\begin{aligned} \text{Power factor} &= \frac{R_2}{\sqrt{R_2^2 + X_2^2}} \\ &= \frac{0.05}{\sqrt{(0.05)^2 + (0.3)^2}} \\ &= 0.1643. \end{aligned}$$

With external resistance:

$$\text{Starting current } I_{st} = \frac{E_2}{\sqrt{(0.08)^2 + (.3)^2}}$$

$$= 3.218E_2 \text{ A.}$$

$$\text{Power factor } \cos\phi = \frac{0.081}{\sqrt{(0.081)^2 + (0.3)^2}} = 0.26.$$

Percentage reduction in the starting current:

$$= \frac{3.28E_2 - 3.218E_2}{3.28E_2} \times 100$$

$$= 1.89\%.$$

Percentage improvement in the power factor:

$$= \frac{0.26 - 0.1643}{0.1643} \times 100$$

$$= 58.24\%.$$

SPEED CONTROL OF DC MOTORS

In practical applications, a motor may be required to perform a number of desirable jobs conforming different load conditions and speed requirements. The availability of DC motors to adjustment of their operating speed over wide ranges and by a variety of methods is one of the important reasons for the strong competitive position of DC machinery in the industrial applications.

The natures of speed control required by different industrial drives are:

- Some drives require a continuously variable speed over the range from zero to full speed, such drives are known as *variable-speed drives*.
- Some drives require only two to three fixed speeds over a region, such drives are known as *multi-speed drives*.
- In some cases, speed is needed for adjusting or setting up the work on driven machine only for a few revolutions per minute. Such a speed is known as *creeping speed*.

For example, crane or hoist requires same torque at all speeds, while a fan or centrifugal pump requires a torque proportional to the square of the speed. For most of the drives, however, a control of speed within $\pm 25\%$ of the normal speed is required.

The speed and torque of a DC motor can be expressed by the following relationships.

$$N \propto \left(\frac{V - I_a R_a}{\phi} \right) \quad (8.19)$$

$$T \propto \phi I_a,$$

where V is the terminal voltage in volts, I_a is the armature current in ampere, R_a is the armature resistance in ohm, ϕ is the flux per pole in wb , N is the speed of DC motor in rpm, and T is the torque in N-m.

Therefore, the speed of DC motors can be regulated by varying ϕ , R , or V . The speed of DC motors can be controlled by the following methods:

1. Field control or flux control method.
2. Armature control method.
3. Applied voltage control.

Speed control of DC shunt motors

Speed of DC shunt motor can be controlled by varying the flux, armature resistance, and applied voltage to the armature terminals.

Various methods of controlling the speed of the shunt motor is given as follows.

Field control method

The speed adjustment of the DC shunt motors by field control may be obtained by one of the following methods.

1. Field reostatic control method.
2. Reluctance control method.
3. Field voltage control.

Field-rehostatic control method

In this method, speed control is obtained by controlling the field current or flux by means of a variable resistance inserted in series with the shunt field winding. The external resistance (R_e) connected in series with the field winding is shown as shunt field regulator. The method of regulating the speed by varying the flux or field current in the shunt field winding is known as flux control method. Circuit diagram illustrating the speed control of a shunt motor is shown in Fig. 1.15.

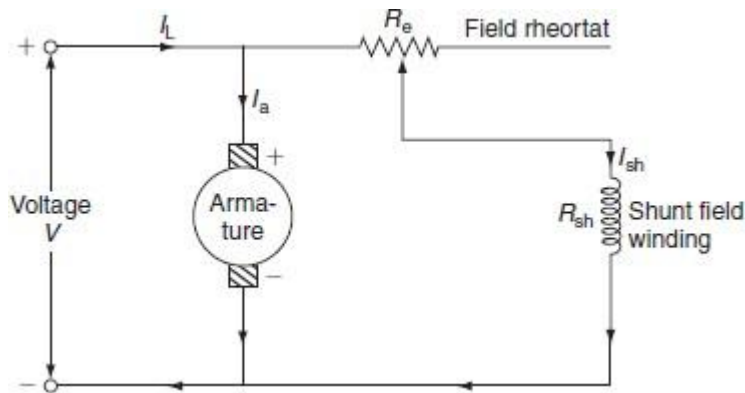

Fig. 1.15 Field-rehostatic control of shunt motor

The variation of external resistance ' R_e ' in the field reduces the field current and hence the flux ' ϕ ' also reduces. The reduction in flux will also result in an increase in the speed. For DC shunt motor, speed is inversely proportional to field flux (ϕ). Since in this method of speed control, flux can be only reduced. Consequently, the motor runs at a speed higher than the normal speed. For this reason, this method of speed control is used to give motor speeds above normal or to correct for a fall in speed due to load.

Reluctance control

In this method of speed control, the motor must be constructed with special mechanical features so that the reluctance of the magnetic circuit can be changed, which makes the motor more expensive. Hence, the variable reluctance type of motor is seldom used.

Field voltage control

This method requires a variable voltage for the field circuit; such a variable supply can be obtained by means of an adjustable electronic rectifier.

Armature control method of DC shunt motor

The speed adjustment of the DC shunt motors by armature control may be obtained by one of the following methods.

1. Armature rheostatic control method.
2. Armature diverter method or potential divider method.

Armature rheostat control method

In armature or rheostatic control method of speed, a variable rheostatic or resistance connected in series with the armature is known as controller resistance. The circuit diagram of the armature control method is shown in [Fig. 8.16](#).

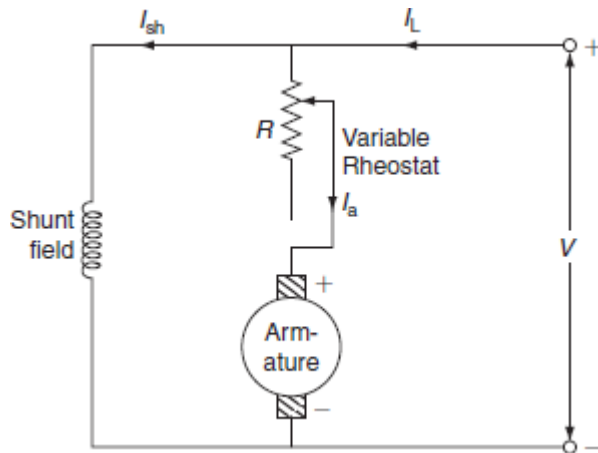

Fig. 1.16 Armature rheostatic control of shunt motor

The speed is directly proportional to the voltage applied across the armature. Voltage across the armature can be controlled by changing resistance connected in series with it. As the controller resistance is increased, the potential difference across the armature is decreased thereby decreasing the armature speed. There is a particular load current at which the speed would be zero is called stalling current. The main disadvantage of this method is speed up to zero is not possible, as it requires large rheostat in series with the armature that is practically impossible.

Armature diverter method or potential divider method

The main disadvantage of the above method can be overcome by connecting a rheostat in a potential divider arrangement as shown in [Fig. 1.17](#).

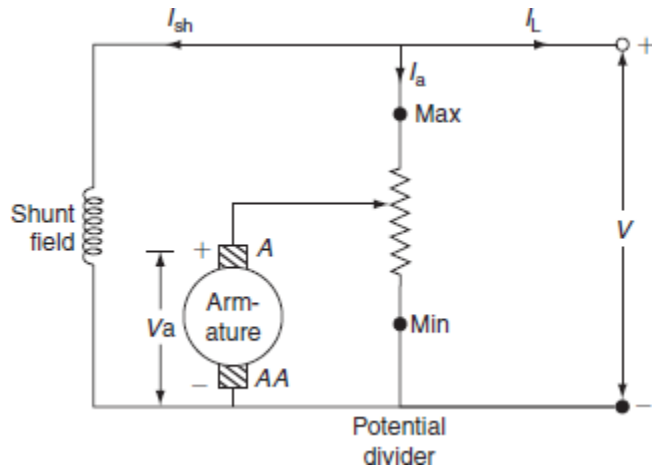

Fig. 1.17 Potential divider method of shunt motor

When the variable rheostat is at minimum position, the voltage across the armature is zero. If the rheostat is moved toward maximum position, the voltage across the armature increases then speed also increases. The variation of speed with the armature voltage is shown in [Fig. 8.18](#).

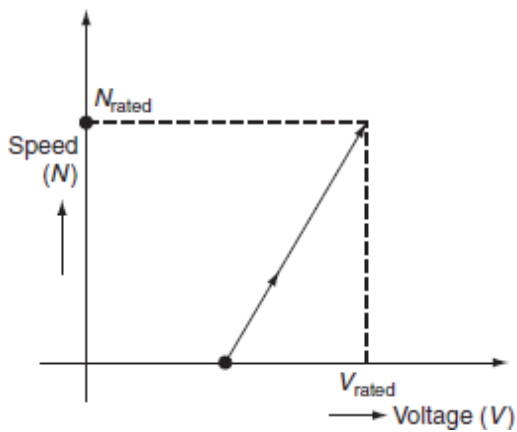

Fig. 1.18 Speed-voltage characteristics

Example: A DC shunt motor rated at 220 V, 15 kW, and 1,500 rpm has a MI-load efficiency of 90%. Its field and armature resistances are 110 Ω and 0.25 Ω , respectively. Determine the value of the resistance to be inserted in series with the armature and the power lost in the armature circuit to reduce the speed to 1,000 rpm when:

1. The load torque is independent of the speed,
2. The load torque is directly proportional to the square of the speed.

Solution:

Given data:

$$V = 220\text{V}$$

$$P = 15,000\text{ W}$$

$$N_1 = 1,500\text{ rpm}$$

$$N_2 = 1,000\text{ rpm}$$

$$R_{\text{sh}} = 110\ \Omega$$

$$R_a = 0.25\ \Omega$$

$$\eta = 0.9.$$

1. Motor output = 10×10^3 W.

$$\text{Motor input} = \frac{\text{Output}}{\eta} = \frac{10 \times 10^3}{0.9} = 11.11\text{ kW.}$$

$$\text{Line current } I_L = \frac{11.11 \times 10^3}{220} = 50.50\text{ A.}$$

From Fig. P.8.1:

$$I_{sh} = \frac{V}{R_{sh}} = \frac{220}{110} = 2\text{A}$$

$$I_L = I_a + I_{sh}$$

$$I_a = I_L - I_{sh} = 50.50 - 2$$

$$= 48.50\text{ A.}$$

$$\text{Back emf, } E_{b1} = V - I_a R_a$$

$$= 220 - 48.50 \times 0.25$$

$$= 207.87\text{ V.}$$

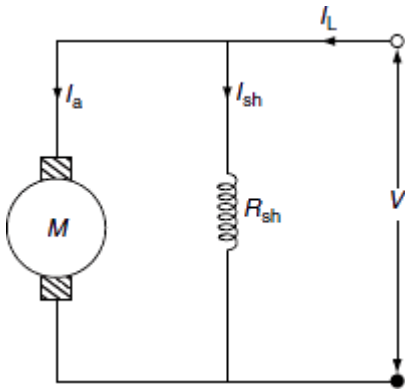

Fig. P.8.1 DC shunt motor

Now, back emf corresponding to 1,000 rpm will be:

$$\frac{E_{b1}}{E_{b2}} = \frac{N_1}{N_2} \quad (\because \text{for shunt motor } E_b \propto N)$$

$$E_{b2} = E_{b1} \times \frac{N_2}{N_1}$$

$$= 207.87 \times \frac{1,000}{1,500}$$

$$= 138.58\text{ V.}$$

$$\text{But, } E_{b2} = V - I_a (R_a + R_{Ext})$$

$$138.58 = 220 - 50.50 (0.25 + R_{Ext})$$

$$0.25 + R_{Ext} = \frac{220 - 138.58}{50.50} = 1.612$$

$$R_{Ext} = 1.612 - 0.25 = 1.362 \Omega.$$

$$\begin{aligned} \therefore \text{The power loss in the armature circuit} &= I_a^2 (R_a + R_{Ext}) \\ &= (50.50)^2 \times 1.612 \\ &= 4.11 \text{ kW.} \end{aligned}$$

2. Given $T \propto N$: (i)

But for shunt motor:

$$T \propto I_a \quad (\phi \text{ is constant}). \quad (\text{ii})$$

From Equations (i) and (ii):

$$I_a \propto N. \quad (\text{iii})$$

I_a corresponding to 15,000 rpm is 50.50 A, then I_a' corresponding to 1,000 rpm is:

$$\begin{aligned} I_a &= I_a' \times \frac{N_2}{N_1} = 50.50 \times \frac{1,000}{1,500} \\ &= 33.66 \text{ A.} \end{aligned}$$

$$\text{Back emf, } E_b = V - I_a' (R_a + R_{Ext})$$

$$138.58 = 220 - 33.66 (0.25 + R_{Ext})$$

$$R_{Ext} = \frac{200 - 138.58}{33.66} - 0.25$$

$$= 2.168 \Omega.$$

$$\begin{aligned} \text{The power loss in the armature} &= I_a'^2 R \\ &= (33.66)^2 \times (0.25 + 2.168) \\ &= 2.739 \text{ kW.} \end{aligned}$$

3. Given $T \propto N^2$:

i.e., for shunt motor, $T \propto I_a \propto N^2$

$$I_a \propto N^2.$$

The armature current corresponding to 1,000 rpm is:

$$I_a^1 = 50.50 \times \left(\frac{1,000}{1,500} \right)^2$$
$$= 22.44 \text{ A.}$$

$$\text{Back emf, } E_b = V - I_a^1 (R_a + R_{\text{Ext}})$$

$$138.58 = 220 - 22.44 (0.25 + R_{\text{Ext}})$$

$$R_{\text{Ext}} = \frac{220 - 138.58}{22.44} - 0.25$$
$$= 3.378 \Omega.$$

$$\begin{aligned} \therefore \text{The power loss in the armature} &= I_a^2 (R_a + R_{\text{Ext}}) \\ &= (22.44)^2 \times (0.25 + 3.378) \\ &= 1.827 \text{ kW.} \end{aligned}$$

Example 8.12: The armature and the field resistances of a 260-V DC shunt motor 0.25 Ω and 160 Ω , respectively. When driving a load of constant torque at 500 rpm, the armature current is 20 A. If it is desired to raise the speed from 500 to 1,000 rpm, what resistance should be inserted in the field circuit? Assume that the magnetic circuit is unsaturated.

Solution:

Given data:

$$V = 200 \text{ V}$$

$$R_a = 0.25 \Omega$$

$$R_{\text{sh}} = 160 \Omega$$

$$I_a = 20 \text{ A}$$

$$N_1 = 500 \text{ rpm}$$

$$N_2 = 1,000 \text{ rpm.}$$

We know that, for shunt motor:

$$E_b \propto N\phi$$

$$E_b \propto N\phi$$

$$\therefore N \propto \frac{E_b}{\phi}$$

$$\text{i.e., } \frac{N_1}{N_2} = \frac{E_{b_1}}{E_{b_2}} \times \frac{\phi_1}{\phi_2} \quad \text{(i)}$$

$$\begin{aligned} \therefore E_{b_1} &= V - I_a R_a \\ &= 200 - 20 \times 0.25 = 195 \text{ V.} \end{aligned}$$

Given that magnetic circuit is unsaturated and torque remains constant:

$$\text{i.e., } \phi \propto I_{sh} \text{ and } T \propto \phi I_a.$$

From the two reaction:

$$\phi_1 I_{a1} = \phi_2 I_{a2}$$

$$\text{and } I_{sh_1} I_{a1} = I_{sh_2} I_{a2}$$

$$\therefore I_{a2} = I_{a1} \times \frac{I_{sh_1}}{I_{sh_2}} \quad \text{(ii)}$$

$$\text{Let } R_{sh_2} = R_{sh_1} + R_{Ext}$$

$$I_{sh_1} = \frac{V}{R_{sh_1}} = \frac{200}{160} = 1.25$$

$$I_{sh_2} = \frac{V}{R_{sh_2}} = \frac{200}{R_{sh_2}}$$

Now, by substituting I_{sh_1} and I_{sh_2} in Equation (ii), we get:

$$\begin{aligned}
 I_{a2} &= 20 \times \frac{1.25}{200 / R_{sh2}} \\
 &= 0.125 \times R_{sh2}. \quad \text{(iii)}
 \end{aligned}$$

But $E_{b2} = V - I_{a2} R_a$

$$\begin{aligned}
 E_{b2} &= 200 - (0.125 \times R_{sh2}) R_a \\
 &= 200 - (0.125 \times 0.25) \times R_{sh2} \\
 &= 200 - 0.03125 R_{sh2}.
 \end{aligned}$$

By substituting E_{b1} and E_{b2} in Equation (i):

We get $\frac{N_1}{N_2} = \frac{E_{b1}}{E_{b2}} \times \frac{\phi_2}{\phi_1}$

$$\frac{N_1}{N_2} = \frac{E_{b1}}{E_{b2}} \times \frac{I_{sh1}}{I_{sh2}} \quad (\because \phi \propto I_{sh})$$

$$\frac{500}{1,000} = \left(\frac{195}{200 - 0.03125 R_{sh2}} \right) \times \frac{(200 / R_{sh2})}{1.25}$$

$$0.5 = \frac{31,200}{R_{sh2}(200 - 0.03125 R_{sh2})}$$

$$200 R_{sh2} - 0.03125 R_{sh2}^2 = 62,400.$$

$$0.03125 R_{sh2}^2 - 200 R_{sh2} + 62,400 = 0.$$

$$\begin{aligned}
 \therefore R_{sh2} &= \frac{200 \pm \sqrt{(200)^2 - 4 \times 0.03125 \times 62,400}}{2 \times 0.03125} \\
 &= \frac{200 \pm 179.44}{0.0625}
 \end{aligned}$$

$$= \frac{20.56}{0.0625} = 328.96 \Omega \quad (\text{neglecting positive sign})$$

$$\therefore R_{sh2} = 328.96 \Omega$$

$$\text{i.e., } R_{sh1} + R_{Ext} = 328.96 \Omega$$

$$\therefore R_{Ext} = 328.96 - 160 = 168.96 \Omega.$$

Example 8.13: A 220-V DC shunt motor, having an armature resistance of 0.5Ω , draws from the main current of 30 A on half-full load. The speed is to be increased to twice half-full-load speed. If the torque of the motor is of constant magnitude, determine the percentage change in flux required.

Solution:

Given data:

$$V = 220\text{V}$$

$$R_a = 0.5 \Omega$$

$$I_{a1} = 30 \text{ A.}$$

Given that speed (N_2) at full load is twice the speed at half-full load

$$\frac{N_2}{N_1} = 2$$

$$\text{back emf, } E_{b1} = V - I_{a1}R_a$$

$$= 220 - 30 \times 0.5$$

$$= 205 \text{ V.}$$

$$E_{b2} = V - I_{a2}R_a = 220 - I_{a2} \times 0.5.$$

We know that, for shunt motor:

$$E \propto N \dot{\phi}$$

$$\text{i.e., } \frac{N_2}{N_1} = \frac{E_{b2}}{E_{b1}} \times \frac{\dot{\phi}_1}{\dot{\phi}_2}$$

$$2 = \frac{220 - 0.5I_{a2}}{200} \times \frac{\dot{\phi}_1}{\dot{\phi}_2}$$

$$\frac{\dot{\phi}_1}{\dot{\phi}_2} = \frac{220 - 0.5I_{a2}}{410}. \quad \text{(i)}$$

Given that the torque remains constant so that:

$$\dot{\phi}_1 I_{a1} = \dot{\phi}_2 I_{a2}$$

$$I_{a2} = \frac{\dot{\phi}_1}{\dot{\phi}_2} \times I_{a1}$$

$$= \frac{\dot{\phi}_1}{\dot{\phi}_2} \times 30. \quad \text{(ii)}$$

Substituting Equation (ii) in Equation (i):

$$\frac{\phi_2}{\phi_1} = \frac{220 - \left(0.5 \times 30 \times \frac{\phi_1}{\phi_2}\right)}{410}$$

Now, let $\frac{\phi_1}{\phi_2} = K$.

$$\therefore K = \frac{220 - \frac{15}{K}}{410}$$

$$410K = 220 - \frac{15}{K}$$

$$410K^2 = 220K - 15$$

$$410K^2 - 220K + 15 = 0$$

$$K = \frac{200 \pm \sqrt{(220)^2 - 4 \times 410 \times 15}}{2 \times 410}$$

$$= \frac{220 \pm 154.272}{820}$$

$$= \frac{220 + 154.272}{820} \quad (\text{neglecting negative sign})$$

$$K = 0.45642$$

i.e., $\frac{\phi_2}{\phi_1} = 0.45642$

$$\therefore \phi_2 = 0.456421$$

$$\begin{aligned} \therefore \text{The percentage change in flux} &= \frac{\phi_1 - \phi_2}{\phi_1} \times 100 \\ &= \frac{\phi_1 - 0.45641}{\phi_1} \times 100 \\ &= 54.35\%. \end{aligned}$$

Example 8.16: A 200-V shunt motor has an armature resistance of 0.5Ω it takes a current of 16 A on full load and runs at 600 rpm. If a resistance of 0.5Ω is placed in the armature circuit, find the ratio of the stalling torque to the full-load torque.

Solution:

Given data:

$$V = 200 \text{ volts.}$$

$$R_a = 0.5 \Omega.$$

$$I_f = I_a = 16 \text{ A.}$$

$$N = 600 \text{ rpm.}$$

$$R_{\text{ext}} = 0.5\Omega.$$

$$\text{Total full-load current} = 16 \text{ A.}$$

$$\text{Total stalling current} = \frac{V}{R_a + R_{\text{ext}}} = \frac{200}{0.5 + 0.5} = 200 \text{ A.}$$

∴ For shunt motor 'ϕ' is constant, so that:

$$T \propto I_a$$

$$\therefore \frac{\text{Stalling torque}}{\text{Full-load torque}} = \frac{\text{stalling current}}{\text{full-load current}} = \frac{200}{16} = 12.5.$$

Example 8.17: A 100-HP and 500-rpm DC shunt motor is driving a grinding mill through gears. The moment of inertia of the mill is 1,265 kg-m². If the current taken by the motor must not to exceed twice full-load current during starting, estimate the minimum time taken to run the mill up to full speed.

Solution:

Given data:

$$\text{Motor rating } (P) = 100 \text{ HP.}$$

$$\begin{aligned} \text{Motor output power} &= 100 \times 735.5 \text{ W} \\ &= 73,550 \text{ W.} \end{aligned}$$

$$\text{The speed of motor } (N) = 500 \text{ rpm.}$$

The moment of inertia (J) = 1,265 kg-m².

$$\text{Motor output } P = \frac{2\pi NT_{\text{FL}}}{60}$$

$$\begin{aligned}\therefore \text{ Full-load torque } T_{\text{FL}} &= \frac{P \times 60}{2\pi N} \\ &= \frac{73,550 \times 60}{2\pi \times 500} = 1,404.70 \text{ N-m} \\ &= \frac{1,404.70}{9.81} = 143.19 \text{ kg-m.}\end{aligned}$$

Given that motor takes twice the [$\therefore 1 \text{ kg} = 9.81\text{N}$] full-load current; hence, it exerts twice the full-load torque.

$$= 2 \times T_{\text{FL}}$$

$$\therefore \text{ Accelerating torque} = 2 \times 143.19$$

$$= 286.38 \text{ kg-m.}$$

$$\text{Angular acceleration } \alpha = \frac{T_{\text{FL}} \times g}{1,265} = 2.223 \text{ rad/sec}^2.$$

We know that:

Angular speed (ω) = angular acceleration \times time

$$\begin{aligned}\omega &= \alpha \times t \\ \therefore t &= \frac{\omega}{\alpha} = \frac{2\pi N}{\alpha \times 60} = \frac{2\pi \times 500}{60 \times 2.23} \\ &= 23.55 \text{ s.}\end{aligned}$$

Speed control of DC series motor

The speed control of DC series motor can be obtained by changing the series field current, flux, or voltage applied across the armature. The methods of the speed control of the series motor are:

1. Field control method.
2. Armature control method.

Field control method

In the series motor, the variation of flux can be brought about by diverting the current flowing through the series field winding by any one of the following methods.

Field diverter's method

In this method, the series field winding is shunted by a variable resistor 'R' known as series field diverter. Any desired amount of current can be passed through the diverter by adjusting its resistance. Hence, the flux can be controlled, i.e., decreased, and consequently the speed of the motor is increased.

The arrangement of field diverter and the speed-armature current characteristics with change in resistance 'R' is shown in Figs. 8.19 (a) and (b).

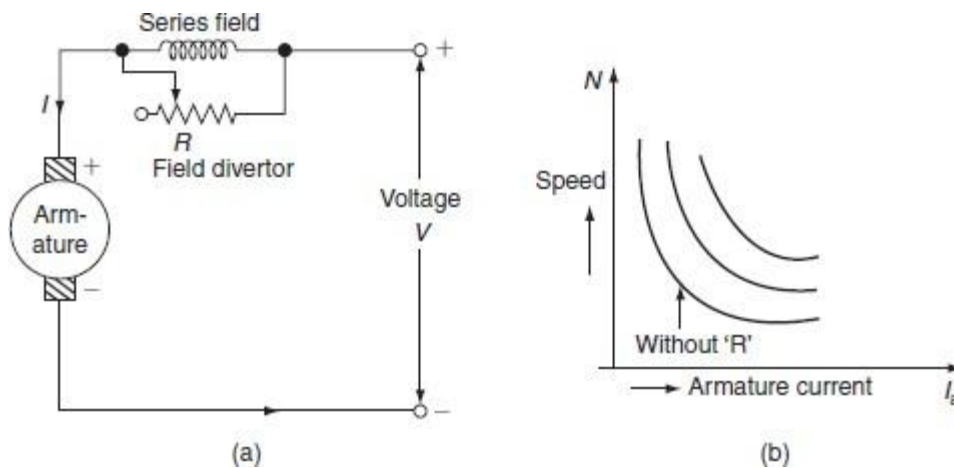

Fig. 8.19 (a) Field diverter method of speed control and (b) Speed-current characteristics

Armature diverter method

In this method, the armature of the motor is shunted with an external variable resistance (R) as shown in [Fig. 8.20](#) is known as armature diverter.

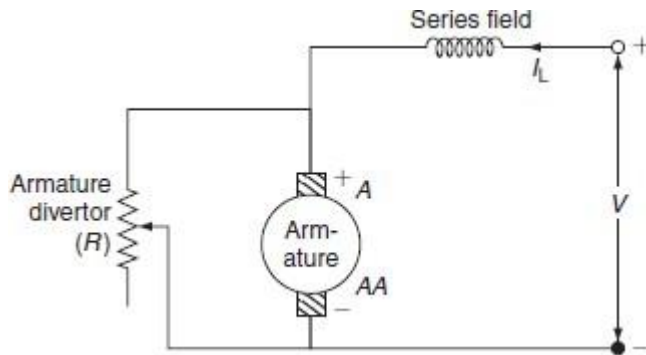

Fig. 8.20 Armature diverter method of speed control

For a given constant load torque, if armature current is reduced due to armature diverter then flux (ϕ) must increase ($\because T \propto I_a$). So that, the motor reacts by drawing more current from the supply. So, the current through field winding increase, so the flux increases and the speed of the motor reduces.

This method of speed control is used to have the speed below the normal value.

Tapped filed method

In this method, the flux change is achieved by providing a number of tapings from the field winding, which are brought out side as shown in [Fig. 8.21](#).

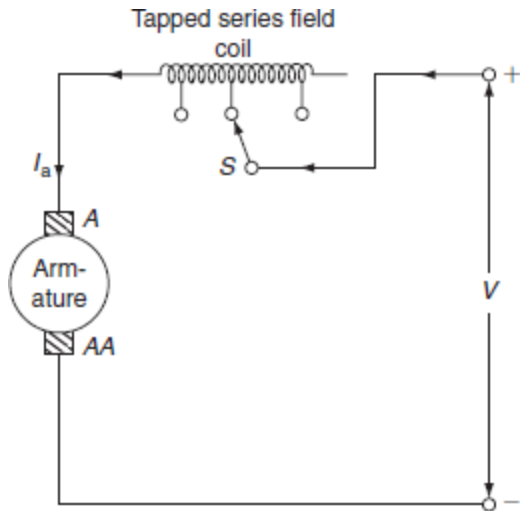

Fig. 8.21 Tapped field speed control

As shown in Fig. 8.21, the selector switch ‘SW’ is provided to select number of turns. So, the net mmf will change. This will cause the change in the speed of DC series motor.

This method is used in electric traction.

Series-parallel connection of field coils

In this method of speed control, several speeds can be obtained by grouping the several field coils as shown in Figs. 8.22 (a) and (b). This method is used generally in case of fan motors.

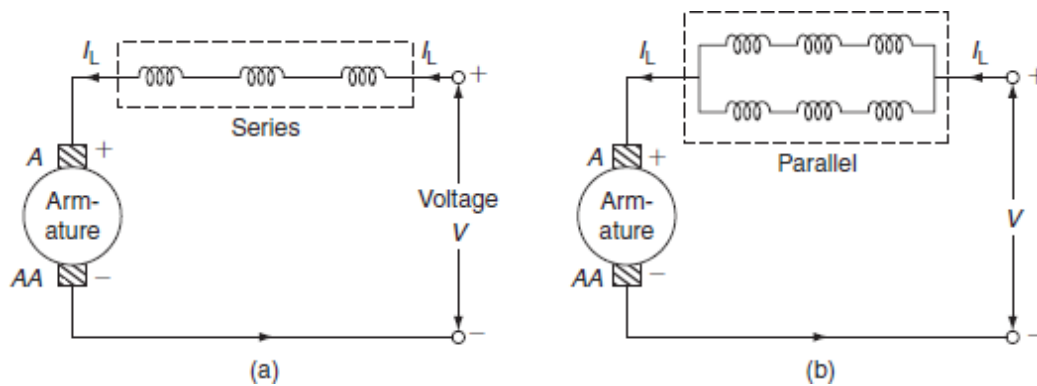

Fig. 8.22 Series-parallel connection of field winding

If the field coils are arranged in series, or parallel, the mmf produced by the coils changes; hence, the flux produced also changes. Hence, the speed is controlled.

Armature control method

Armature resistance control method is the most common method employed for DC series motor. The arrangement and speed-current characteristics of series motor is shown in Figs. 8.23 (a) and (b).

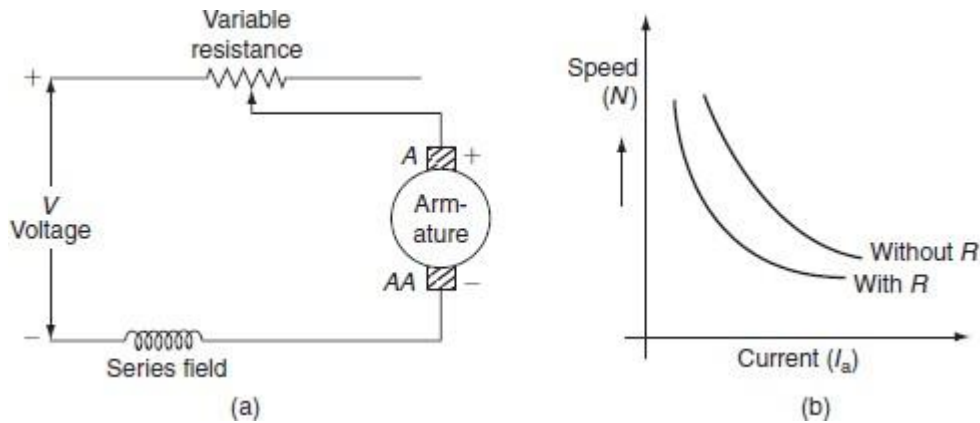

Fig. 8.23 (a) Armature control method and (b) Speed-current characteristics

By increasing the resistance in series with the armature, voltage drop across this resistance occurs. So that, the voltage applied across the armature terminals can be decreased. As the speed is directly proportional to the voltage across the armature, the speed reduces.

Example 8.18: A 400-V series motor has an armature resistance of 0.2Ω and a series field resistance of 0.5Ω . It takes a current of 160 A at a speed of 800 rpm. Find the speed of the motor if a diverter of resistance 0.4Ω is connected across the field, the load torque being kept constant.

Neglect armature reaction and assume that flux is proportional to the current.

Solution:

Given data:

$$V = 400\text{V}$$

$$R_a = 0.2 \Omega$$

$$R_{se} = 0.5 \Omega$$

$$R_{div} = 0.4\Omega$$

$$I_{a1} = 160 \text{ A}$$

$$N_1 = 800 \text{ rpm.}$$

For the series motor $I_{a1} = I_{f1} = I_{se1} = 160 \text{ A}$.

Back emf corresponding to the speed 800 rpm is:

$$\begin{aligned} E_{b1} &= V - I_{a1}(R_a + R_{se1}) \\ &= 400 - 160(0.2 + 0.5) \\ &= 288\text{V.} \end{aligned}$$

Let, when a diverter of resistance 0.4Ω is connected across field winding current flowing through the armature be I_{a2} .

Given that the torque remains constant, then:

$$\varphi_1 I_{a1} = \varphi_2 I_{a2}.$$

But for the series motor $\varphi \propto I_{se}$:

$$\therefore I_{a1}^2 = \varphi I_{a2}$$

Now, from the Fig. P.8.2, the current flowing through the diverter is:

$$I_{se2} = I_{a2} \times \frac{R_{div}}{R_{div} + R_{se}}$$

$$= I_{a2} \times \frac{0.4}{0.4 + 0.5} = 0.44 I_{a2}$$

But $\phi_2 \propto I_{se2}$

$$\therefore I_{a1}^2 = 0.44 I_{a2}^2$$

$$I_{a2}^2 = \frac{I_{a1}^2}{0.44}$$

$$I_{a2} = \frac{I_{a1}}{\sqrt{0.44}} = \frac{160}{\sqrt{0.44}} = 241.20 \text{ A.}$$

$$\text{And } I_{se2} = 0.44 I_{a2} = 0.44 \times 241.20$$

$$= 106.1319 \text{ A.}$$

Now, back emf, $E_{b2} = V - I_{a2}R_a - I_{se2}R_{se}$

$$= 400 - 241.20 \times 0.2 - 106.1319 \times 0.5$$

$$= 400 - 48.24 - 53.06$$

$$= 298.7 \text{ V.}$$

We know that:

$$N \propto \frac{E_b}{\phi}$$

$$\therefore \frac{N_1}{N_2} = \frac{E_{b1}}{E_{b2}} \times \frac{\phi_2}{\phi_1}$$

$$N_2 = N_1 \times \frac{E_{b1}}{E_{b2}} \times \frac{\phi_1}{\phi_2}$$

$$\therefore N_2 = N_1 \times \frac{E_{b1}}{E_{b2}} \times \frac{I_{se1}}{I_{se2}}$$

$$= 800 \times \frac{298.7}{288} \times \frac{160}{106.1319}$$

$$= 1,250.85 \text{ rpm.}$$

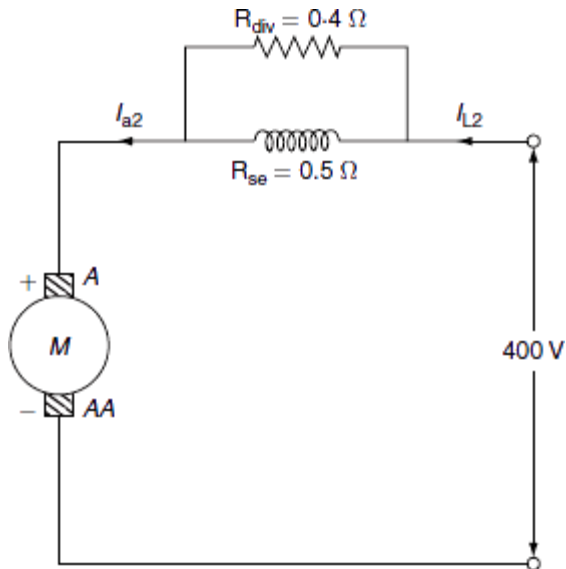

Fig. P.8.2 DC Series motor

Example 8.19: A 220-V and 10-HP (metric) shunt motor has field and armature resistances as of $120\ \Omega$ and $0.25\ \Omega$ respectively. Calculate the resistance to be inserted in the armature circuit to reduce the speed to 700 rpm from 950 rpm, if the full-load efficiency is 80% and the torque varied as the square of the speed.

Solution:

Given data:

$$V = 220\text{V}$$

$$\text{Motor rating} = 10\ \text{HP}$$

$$R_{\text{sh}} = 120\ \Omega$$

$$R_a = 0.25\ \Omega$$

$$N_1 = 950\ \text{rpm}$$

$$N_2 = 700\ \text{rpm}$$

$$\eta = 80\% = 0.8.$$

$$\text{Motor output power} = (P_0) = 10\ \text{HP}$$

$$= 10 \times 735.5 [\because 1\text{HP} = 735.5\ \text{W}]$$

$$= 7,355 \text{ W.}$$

$$\begin{aligned}\text{Motor input power } (P_i) &= \frac{P_0}{\eta} = \frac{7,355}{0.8} \\ &= 9,193.75 \\ &\cong 9.194 \text{ W.}\end{aligned}$$

We know that, motor electric input = $VI = P_i$

$$\therefore 9,194 = 220 \times I$$

$$I = 41.78 \text{ A.}$$

We know that $T \propto \phi I_a$.

For shunt motor ' ϕ ' is constant.

$$\text{Hence, } \frac{T_1}{T_2} = \frac{I_{a1}}{I_{a2}}. \quad (8.19.1)$$

Given that $T \propto N^2$

$$\therefore \frac{T_1}{T_2} = \frac{N_1^2}{N_2^2}. \quad (8.19.2)$$

From Equations (8.19.1) and (8.19.2):

$$\frac{N_1^2}{N_2^2} = \frac{I_{a1}}{I_{a2}}. \quad (8.19.3)$$

From Fig. P.8.3,

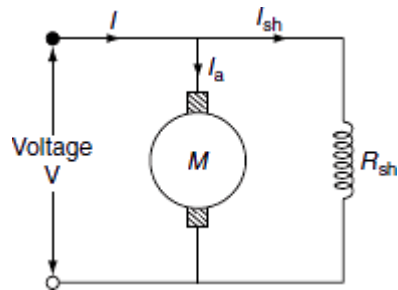

Fig. P.8.3 DC shunt motor

$$\begin{aligned} I_{a1} &= I_{L1} - I_{sh1} \\ &= 41.78 - \frac{V}{R_{sh}} \\ &= 41.78 - \frac{220}{120} \\ &= 39.94 \text{ A.} \end{aligned}$$

From Equation (8.19.3):

$$\begin{aligned} I_{a2} &= \frac{N_1^2}{N_2^2} \times I_{a1} \\ &= \frac{700^2}{950^2} \times 39.94 = 21.68 \text{ A.} \end{aligned}$$

We know that:

$$N \propto \frac{E_b}{\phi}$$

For the shunt motor $N \propto E_b$:

$$\frac{N_1}{N_2} = \frac{E_{b1}}{E_{b2}} \quad (8.19.4)$$

From the data:

$$\begin{aligned} E_{b1} &= V - I_{a1} R_a \quad [\text{for motor, } V = E_b + I_a R_a] \\ &= 220 - 39.94 \times 0.25 \\ &= 210 \text{ V.} \end{aligned}$$

$$\begin{aligned} \text{And } E_{b2} &= V - I_{a2} (R_a + R_{\text{ext}}) \\ &= 220 - 21.68 (0.25 + R_{\text{ext}}). \end{aligned}$$

Substitute E_{b1} and E_{b2} in Equation (8.19.4):

$$\begin{aligned} \therefore \frac{950}{700} &= \frac{210}{220 - 21.68 (0.25 + R_{\text{ext}})} \\ 220 - 21.68(0.25 + R_{\text{ext}}) &= \frac{210 \times 700}{950} = 154.73 \\ 0.25 + R_{\text{ext}} &= \frac{-154.73 + 220}{21.68} = 3.01 \\ R_{\text{ext}} &= 3.01 - 0.25 = 2.76 \Omega \\ \therefore R_{\text{ext}} &= 2.76 \Omega. \end{aligned}$$

Example 8.20: A DC series motor drives a load, the torque of which varies as the square of the speed. The motor takes a current of 30 A, when the speed is 600 rpm. Determine the speed and

current when the field winding is shunted by a diverter; the resistance of which is 1.5 times that of the field winding. The losses may be neglected.

Solution:

Given data (Fig. P.8.4):

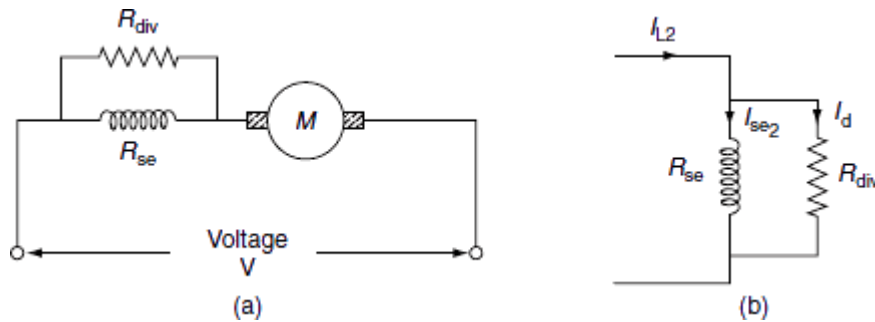

Fig. P.8.4 DC series motor

$$I = I_{a1} = I_{se1} = I_{L1} = 30 \text{ A}$$

$$N_1 = 600 \text{ rpm}$$

$$R_{div} = 1.5 R_{se}.$$

After connecting the diverter:

$$\text{Total resistance} = R_{div} + R_{se}.$$

$$\text{Line current} = I_{L2} = I_{a2}.$$

$$\text{Speed} = N_2$$

$$\begin{aligned}
 I_{se2} &= I_{L2} \times \frac{R_{div}}{R_{se} + R_{div}} \\
 &= I_{L2} \times \frac{1.5 \times R_{sc}}{R_{sc} + 1.5R_{sc}} = 0.6 I_{L2}.
 \end{aligned}$$

We know that:

$$N \propto \frac{E_b}{\phi}, \quad \phi \propto I_{sc}.$$

Since the losses are negligible $E_b = V = \text{constant}$:

$$\begin{aligned}
 \therefore N &\propto \frac{1}{\phi} \\
 \frac{N_2}{N_1} &= \frac{\phi_1}{\phi_2} = \frac{I_{se1}}{I_{se2}} \\
 &= \frac{30}{0.6 I_{L2}} = \frac{50}{I_{L2}}. \tag{i}
 \end{aligned}$$

We know that:

$$\begin{aligned}
 T &\propto \phi I_a, \quad \phi \propto I_{se} \\
 \frac{T_1}{T_2} &= \frac{\phi_1}{\phi_2} \times \frac{I_{a1}}{I_{a2}} = \frac{I_{a1}}{I_{a2}} \times \frac{I_{se1}}{I_{se2}} \\
 &= \frac{30 \times 30}{I_{L2} \times 0.6 I_{L2}} = \frac{1,500}{I_{L2}^2}. \tag{ii}
 \end{aligned}$$

Given that $T \propto N^2$:

$$\frac{N_2}{N_1} = \left(\frac{N_1}{N_2} \right)^2$$

$$\frac{1500}{I_{L2}^2} = \left(\frac{I_{L2}}{50} \right)^2 \quad [\because \text{from Equations (i) and (ii)}]$$

$$I_{L2}^4 = 1,500 \times 50^2$$

$$I_{L2} = 44 \text{ A.}$$

Substitute I_{L2} in Equation (i):

$$\frac{N_2}{N_1} = \frac{50}{I_{L2}}$$

$$N_2 \frac{50}{44} \times 600 = 681.7 \text{ rpm}$$

$$\therefore N_2 = 681.7 \text{ rpm.}$$

Example 8.21: A 500-V DC series motor runs at 500 rpm and takes 60 A; the resistances of the field and the armature are 0.3 and 0.2 Ω , respectively. Calculate the value of the resistance to be shunted with series field winding in order that the speed may be increased to, 600 rpm, if the torque were to remain constant. Saturation may be neglected.

Solution:

Given that:

$$V = 500 \text{ V}$$

$$N_1 = 500 \text{ rpm}$$

$$I_{a1} = 60 \text{ A}$$

$$R_a = 0.2 \Omega$$

$$R_{se} = 0.3 \Omega$$

$$N_2 = 600 \text{ rpm}$$

$$I_{L1} = I_{a1} = I_{se1} = 60 \text{ A.}$$

After connecting resistance across field winding, let I_{a2} be the armature current (Fig. P.8.5).

$$\therefore I_{se2} = I_{a2} \times \frac{R_{ext}}{R_{ext} + 0.3} \quad (i)$$

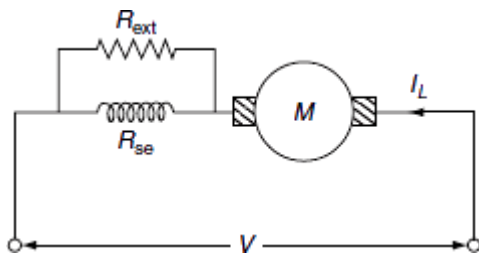

Fig. P.8.5 DC series motor

Given that the load torque is constant:

$$T_1 = T_2.$$

We know that:

$$T \propto \phi I_a \text{ and } N \propto E_b / \phi$$

$$\therefore I_{a1} \phi_1 = I_{a2} \phi_2. \quad (ii)$$

For series motor $\phi \propto I_{se}$:

$$\therefore I_{a1} I_{se1} = I_{a2} I_{se2}$$

$$I_{a1}^2 = I_{a2} \times I_{se2}$$

$$I_{a1}^2 = I_{a2} \times \left[I_{a2} \times \frac{R_{ext}}{R_{ext} + 0.3} \right]$$

$$60^2 = I_{a2}^2 \left[\frac{R_{ext}}{R_{ext} + 0.3} \right] \quad (iii)$$

And from the circuit:

$$N \propto E_b / \phi$$

$$\frac{N_1}{N_2} = \frac{E_{b1}}{E_{b2}} \times \frac{\phi_2}{\phi_1}$$

$$\text{or } \frac{N_2}{N_1} = \frac{E_{b2}}{E_{b1}} \times \frac{\phi_1}{\phi_2}$$

$$\frac{600}{500} = \frac{V - I_{a2} R_{a2}}{V - I_{a1} R_{a1}} \times \frac{\phi_1}{\phi_2}$$

$$\frac{600}{500} = \frac{500 - I_{a2} \left[0.2 + \frac{R_{ext} \times 0.3}{R_{ext} + 0.3} \right]}{500 - 60(0.2 + 0.3)} \times \frac{I_{se1}}{I_{se2}}$$

$$\frac{600 \times 470}{500 \times 60} = \frac{500 - I_{a2} \left(0.2 + \frac{R_{ext} \times 0.3}{R_{ext} + 0.3} \right)}{I_{a2} \times \frac{R_{ext}}{R_{ext} + 0.3}}$$

$$9.4 = \frac{500 - I_{a2} \left(0.2 + \frac{R_{ext} \times 0.3}{R_{ext} + 0.3} \right)}{I_{a2} \left(\frac{R_{ext}}{R_{ext} + 0.3} \right)} \quad (iv)$$

From Equation (iii):

$$\frac{60^2}{I_{a2}} = I_{a2} \left[\frac{R_{ext}}{R_{ext} + 0.3} \right]. \quad (v)$$

Substitute Equation (v) in Equation (iv):

$$9.4 = \frac{500 - 0.2I_{a2} - 0.3 \times \frac{60^2}{I_{a2}}}{\frac{60^2}{I_{a2}}}$$
$$\frac{60^2 \times 9.4}{I_{a2}} = 500 - 0.2I_{a2} - \frac{0.3 \times 60^2}{I_{a2}}$$
$$500I_{a2} - 0.2I_{a2}^2 - 1,080 - 33,840 = 0$$
$$0.2I_{a2}^2 - 500I_{a2} + 34,920 = 0$$
$$I_{a2} = \frac{+500 \pm \sqrt{500^2 - 4 \times 0.2 \times 34,920}}{2 \times 0.2}$$
$$I_{a2} = \frac{500 \pm 471.23}{0.4} = 71.9 \text{ A.}$$

Substitute I_{a2} in Equation (iii):

$$60^2 = I_{a2}^2 \times \frac{R_{ext}}{R_{ext} + 0.3}$$

$$60^2 = 71.9^2 \times \frac{R_{ext}}{R_{ext} + 0.3}$$

$$R_{ext} + 0.3 = 1.436 R_{ext}$$

$$0.436 R_{ext} = 0.3$$

$$R_{ext} = \frac{0.3}{0.436} = 0.6878 \Omega$$

$$\therefore R_{ext} = 0.6878 \Omega.$$

Example 8.22: A 440-V series motor takes a line current of 60 A and runs at a speed of 750 rpm. What resistance should be connected in series with the armature to reduce the speed to 500 rpm. The load torque at this new speed is 75% of its previous value. The resistance of the armature and the series field are 0.05 Ω and 0.015 Ω , respectively. Assume that flux is proportional to load.

Solution:

Given data:

$$V = 440 \text{ V}$$

$$I_L = 60 \text{ A}$$

$$N_1 = 750 \text{ rpm}$$

$$N_2 = 500 \text{ rpm}$$

$$\text{Torque at 500 rpm} = T_1$$

$$\text{Torque at 750 rpm} = T_2 = 0.75T_1$$

$$R_a = 0.05 \Omega$$

$$R_{se} = 0.015 \Omega.$$

We know that:

$$T \propto \phi I_a \quad \text{and} \quad \phi \propto I_{se}$$

$$T_1 \propto \phi_1 I_{a1} \propto I_{a1}^2$$

$$T_2 \propto \phi_2 I_{a2} \propto I_{a2}^2$$

$$\therefore \frac{T_1}{T_2} = \frac{I_{a1}^2}{I_{a2}^2}$$

$$I_{a2}^2 = I_{a1}^2 \times \frac{T_2}{T_1}$$

$$= (60)^2 \times \frac{0.75 T_1}{T_1}$$

$$= 2,700$$

$$\therefore I_{a2} = 51.96 \text{ A}$$

$$\begin{aligned} \therefore E_{b1} &= V - I_{a1} (R_a + R_{se}) \\ &= 440 - 60 (0.05 + 0.015) \\ &= 436.1 \text{ V.} \end{aligned}$$

$$\begin{aligned} E_{b2} &= V - I_{a2} (R_a + R_{se} + R_{ext}) \\ &= 440 - 51.96 (0.05 + 0.015 + R_{ext}) \\ &= 440 - 51.96 (0.065 + R_{ext}). \end{aligned} \tag{i}$$

But $E_b \propto N \phi$

$$\frac{E_{b1}}{E_{b2}} = \frac{N_1}{N_2} \times \frac{\phi_1}{\phi_2}$$

$$\frac{E_{b1}}{E_{b2}} = \frac{N_1}{N_2} \times \frac{I_{a1}}{I_{a2}}$$

$$E_{b2} = \frac{N_2}{N_1} \times \frac{I_{a2}}{I_{a1}} \times E_{b1}$$

$$= \frac{1}{500} \times \frac{1}{51.96} \times 436.1$$

(ii)

$$= 251.77 \text{ V.}$$

From Equations (i) and (ii):

$$\therefore 251.77 = 440 - 51.96 (0.065 + R_{\text{ext}})$$

$$0.065 + R_{\text{ext}} = 3.622$$

$$R_{\text{ext}} = 3.55 \Omega.$$

Example 8.23: A series motor with series field and armature resistance of 0.06Ω and 0.02Ω , respectively, is connected across 440-V mains. The armature takes 60 A and its speed is 850 rpm. Determine its speed when it takes 85 A from this very and the excitation is increased by 20%.

Solution:

Given data (Fig. P.8.6):

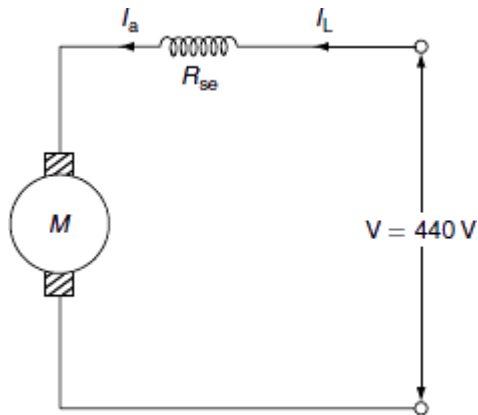

Fig. P.8.6 DC series motor

$$V = 440 \text{ V}$$

$$N_1 = 850 \text{ rpm}$$

$$I_{a1} = 60 \text{ A}$$

$$I_{a2} = 85 \text{ A}$$

$$R_a = 0.02 \ \Omega$$

$$R_{se} = 0.06 \ \Omega$$

$$\phi_2 = 1.15 \phi_1.$$

From the speed equation:

$$\frac{E_{b2}}{E_{b1}} = \frac{N_2}{N_1} \times \frac{\phi_1}{\phi_2}$$

$$\begin{aligned} E_{b1} &= 440 - 60 \times (0.02 + 0.06) \\ &= 435.2 \text{ V} \end{aligned}$$

$$\begin{aligned} E_{b2} &= 440 - 85 (0.8) \\ &= 372 \text{ V} \end{aligned}$$

$$\therefore \frac{N_2}{N_1} = \frac{E_{b2}}{E_{b1}} \times \frac{\phi_2}{\phi_1}$$

$$\begin{aligned} &= \frac{372}{435.2} \times \frac{1.15\phi_1}{\phi_1} \\ &= 0.98 \end{aligned}$$

$$\therefore N_2 = 0.98 \times 850 = 833 \text{ rpm.}$$

Ward–Leonard method of speed control

The speed control of DC motor accomplished by means of an adjustable voltage generator is called the Ward–Leonard system. If it is desired to have wide and very sensitive speed control, then this system is more generally used. The system is as shown in [Fig. 8.24](#).

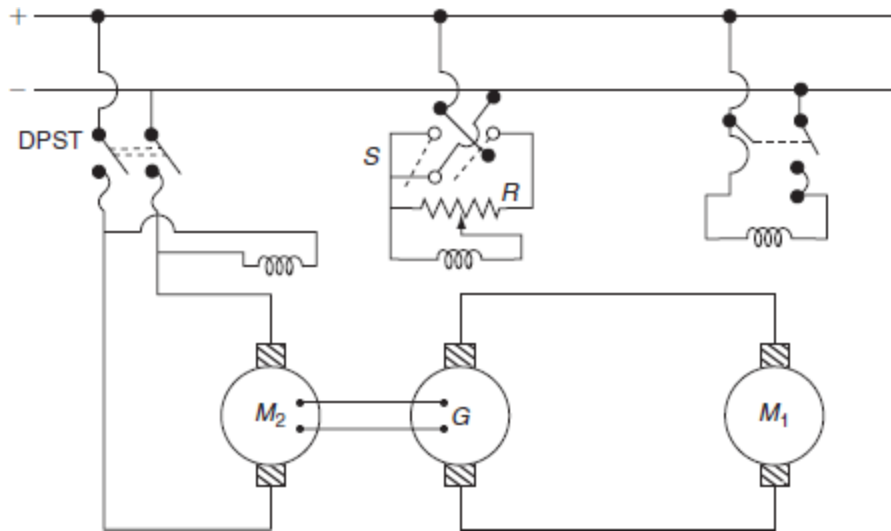

Fig. 8.24 Ward–Leonard speed control system

In Fig. 8.24, R is the potential divider, M_1 is the main motor whose speed is to be controlled, G is the separately excited generator that feeds the armature of the motor M_1 , M_2 is the driving motor that drive generator and main motor, and S is a double-throw switch.

As shown in Fig. 8.24, M_1 is the main motor whose speed control is required. The field winding of this motor is permanently connected to DC supply and armature is fed from variable voltage so that the motor can run at any desired speed. To provide this variable, the voltage motor generator set is used, in which the generator is directly coupled to a constant speed motor. The field circuit of this generator is separately excited from the available DC supply through a reversing switch and a potential divider ‘ R ’ so that its excitation can be varied from zero to maximum in both the directions. Thus, the generator output voltage can be varied from zero to maximum value. The polarity of generating voltage will be reversed with the help of reversing switch; thus, the change of the direction of the motor M_1 can be achieved.

This system is commonly employed for elevators, hoists, and main drive in steel mills, as this method can give unlimited speed control in either direction. Since the generator voltage can be varied gradually from zero, no extra starting equipment is required to start up the main motor smoothly. The important feature of the Ward–Leonard system is its regenerative action. The modified Ward–Leonard is called Ward–Leonard–Ilgner system in which a flywheel is used in addition to motor-generator set, whose function is to reduce fluctuations in the power demand from the supply circuit. When the main motor M_1 becomes suddenly overloaded, the driving motor M_2 slows down, thus allowing the inertia of the flywheel to supply a part of the overload. However, when the load is suddenly thrown off the main motor M_1 , then M_2 speeds up thereby again stores energy in the flywheel.

Advantages of Ward–Leonard system

- A wide range of speed from standstill to high speed in either direction.
- Starting without any extra starting equipment.
- Extremely good speed regulation at any speed.

Disadvantages

- High capital cost due to the motor generator set.
- The efficiency of this method is not so high.

SPEED CONTROL OF INDUCTION MOTORS

A three-phase induction motor is practically a constant-speed motor as the DC shunt motor. The speed control of DC shunt motor can be achieved easily, but it is difficult to achieve the smooth speed control of the induction motor because the performance of the induction motor in terms of its power factor, efficiency, etc. gets adversely effected.

We know that for the induction motor:

The speed of motor $N = N_s (1-S)$. **(8.20)**

$$\text{And, the torque } T \propto \frac{SE_2^2 R_2}{R_2^2 + (SX_2)^2} \quad \text{(8.21)}$$

From the above two relations:

The speed of the induction motor can be changed either by changing its synchronous speed (N_s) or by changing the slip and also the parameters R_2 and E_2 are changed then to keep torque constant for constant load condition, slip will change, then its speed gets effected.

Thus, the following methods are used for controlling the speed of the three-phase induction motors.

From stator side

1. Supply frequency control.
2. Supply voltage control.

3. Controlling the number of stator poles.

From rotor side

1. Adding external resistance in the rotor circuit.
2. Cascade control.

Stator side control

Thus, following any one method is used for controlling the speed of the three-phase induction motors on stator side.

Speed control by varying the supply frequency

This method is impractical for most applications because the frequency of the supply system must remain fixed. The synchronous speed is given by:

$$N_s = \frac{120f}{P}. \quad (8.22)$$

Thus, by controlling the supply frequency, the synchronous speed can be controlled over a wide range that gives the smooth speed control of the induction motor. Hence, in this method, variable voltage and frequency is achieved by using converter and inverter circuit as shown in Fig. 8.25.

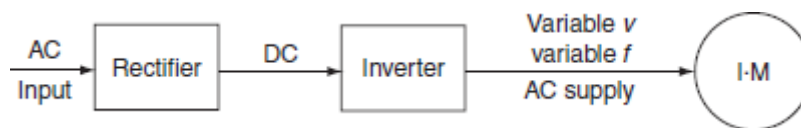

Fig. 8.25 Electronic circuit for variable frequency

Rectifier converts normal AC supply to constant DC voltage. This DC supply is then given to inverter that converts constant DC to variable AC voltage and frequency.

Supply voltage control

This is a slip-control method with constant frequency variable supply voltage. In this method, the voltage applied to the stator is varied.

We know that:

$$T \propto \frac{SE_2^2 R_2}{R_2^2 + (SX_2)^2}.$$

But, at standstill, rotor-induced emf depends on the supply voltage.

$$\text{i.e., } E_2 \propto V.$$

In the operating region of an induction motor or for low-slip region $(SX_2) \ll R_2$.

$$\text{So that } T = \frac{SE_2^2}{R_2}.$$

Rotor resistance is constant; therefore:

$$T \propto SE_2^2 \propto SV^2. \quad (8.23)$$

From the above relation, if the supply voltage 'V' is reduced below the rated value torque developed by the induction motor reduce. But, so as to maintain the torque constant for constant load, it is necessary to increase the slip thereby decreasing the speed of induction motor.

This method of speed control is simple, low initial cost, and has low maintenance cost, but it has limited use because, the operation at voltage is restricted by magnetic saturation and also large change in voltage is required for relatively for small change in speed.

Speed control by changing the number of poles

In this method, it is possible to have one or two speeds, one double of the other which is generally obtained by changing the number of poles. It is also called as pole-changing method. Changing the number of poles is simply affected by changing the connections of stator winding with the help of simple switches. Due to this number of stator poles gets changed, in the ratio 2:1. Hence, either of the two speeds can be selected.

Consider the single phase of a certain three-phase winding when the supply is across the two terminals and the third is kept open, as shown in Fig. 8.26

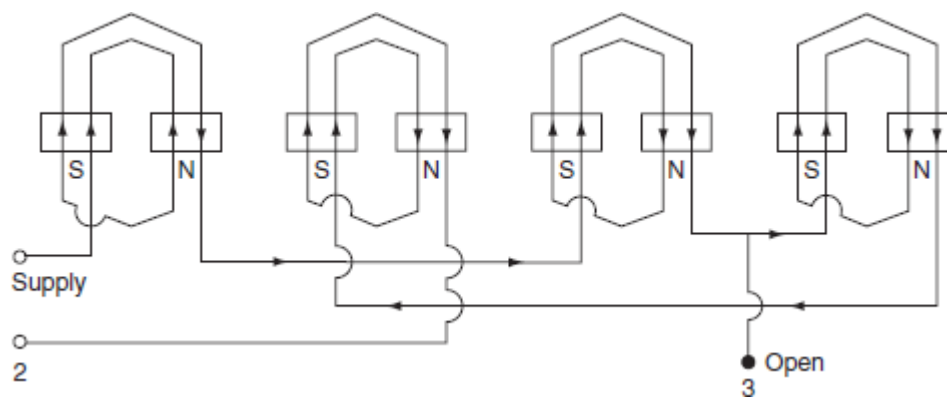

Fig. 8.26 Eight-pole winding

Let the conductors which are carrying current in upward direction from South Pole, while the conductors which carry current in downward direction from north polarity. The distribution of current is as shown in Fig. 8.26 due to these eight poles get formed.

Now, the two terminals 1 and 2 which the supply was given earlier are joined together and supply is given to the common point of the first two terminals and the third terminal, on observing the direction of current, it will be found that total eight poles are changed to four poles only as shown in Fig. 8.27; so that, the speed now will be double of the previous value.

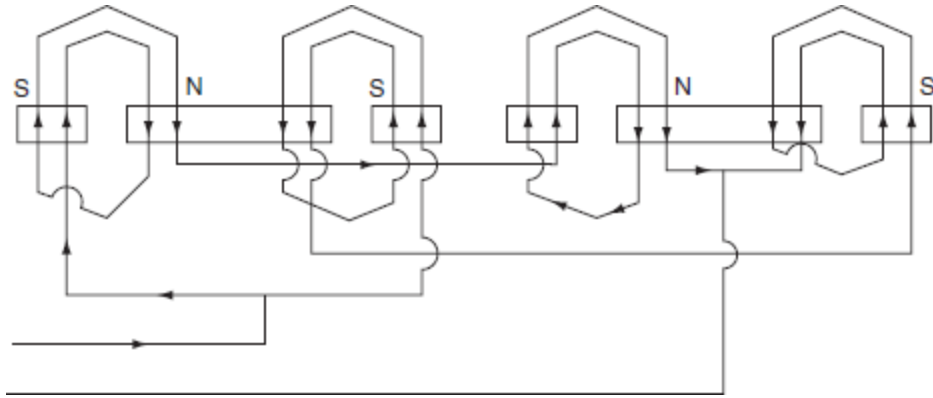

Fig. 8.27 Four-pole winding

8.8.4 Control on rotor side

The following method is used for controlling the speed of three-phase induction motors on rotor side.

Cascade control

Multiple speeds are derived and motors are sometimes operated in tandem or cascade. If two motors are to be mechanically coupled together, one of the machines must be phase-wound motor while the other can be a squirrel-cage motor. The first is connected to the mains in the usual way, while that of the second stator is fed from the rotor winding of the first, as shown in Fig. 8.28.

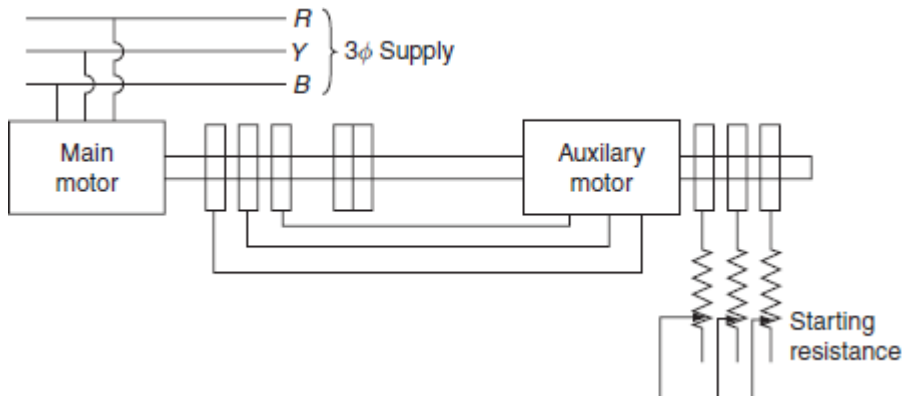

Fig. 8.28 Cascade control of induction motor

When two motors are operated in tandem, they may be running in the same direction, or the phase rotation of one motor may be reversed, thus tending to make it in reverse direction. In both the cases, the set will run after it is started, but in the later case, no starting torque is developed so that this connection is rarely used.

If P_1 and P_2 be the number poles of both the machines, then the synchronous speed of the set is depending on total number of poles $P_1 + P_2$ in the first case and $P_1 - P_2$ in the second. If the number of poles of the two motors is not equal; four speeds possible: two for tandem operation and one for each motor separately.

Let ' P_1 ' be the poles of main motor and ' P_2 ' be the poles of the auxiliary motor.

If ' S ' is the slip, the actual rotating speed of the motor is:

$$N_1 = (1 - S) N_s$$

$$= (1 - S) \left(\frac{120f}{P_1} \right) = \frac{120}{P_1} (f - S \times f). \quad (8.24)$$

But, for the induction motor, the frequency of the rotor current is ' S ' times of supply frequency.

Frequency $f_r = Sf$. **(8.25)**

Let, f_{r1} be the frequency of the rotor current of the main motor and the frequency of the rotor current of the auxiliary motor is f_{r2} then:

The speed of the main motor $N_1 = N_1 = \frac{120}{P_1} (f - f_{r1}). \quad (8.26)$

The speed of the auxiliary motor $N_2 = N_2 = \frac{120}{P_2} (f_{r1} - f_{r2})$.

As f_{r1} is so small, so f_{r2} will be very small; so that, it can be neglected.

$$\therefore N_2 = \frac{120}{P_2}(f_{r1}). \quad (8.27)$$

Since, the two motors are coupled together:

$$\begin{aligned} N_1 &= N_2 \\ \frac{120}{P_1}(f - f_{r1}) &= \frac{120}{P_2} f_{r1} \\ (f - f_{r1})P_2 &= P_1 f_{r1} \\ fP_2 &= f_{r1}(P_1 + P_2) \\ \therefore f_{r1} &= \frac{fP_2}{P_1 + P_2}. \end{aligned}$$

Substituting f_{r1} from above equation in Equation (8.27), we get:

$$\begin{aligned} N_2 &= \frac{120}{P_2} \times \frac{fP_2}{P_1 + P_2} \\ &= \frac{120f}{P_1 + P_2}. \end{aligned} \quad (8.28)$$

Equation (8.28) relation shows that the speed of the set is that of a single machine having the number of poles equal to the sum of the numbers of poles of the two machines. Hence, the set can give four different speeds. If it is required to have the speeds above the normal, the torque of the second motor is reversed by simply changing two of the leads of the second. This is known as differential cascading.

Example 8.25: A six-pole and 50-Hz slip ring induction motor with a rotor resistance per phase of 0.2Ω and a stand-still reactance of 1.0Ω per phase runs at 960 rpm at full load. Calculate the resistance to be inserted in the rotor circuit to reduce the speed to 800 rpm, if the torque remains unaltered.

Solution:

Given data:

$$P = 6$$

$$F = 50 \text{ Hz}$$

$$R/\text{ph} = 0.2 \ \Omega$$

$$N_1 = 960 \text{ rpm}$$

$$N_2 = 800 \text{ rpm.}$$

$$\text{Synchronous speed } N_s = \frac{120f}{P} = \frac{120 \times 50}{6} = 1,000 \text{ rpm.}$$

The slip of the motor when N running at 960 rpm is:

$$S = \frac{N_s - N_r}{N_s} = \frac{1,000 - 960}{1,000} = 0.04.$$

Let the motor input = P .

Full-load current = I_2 .

$$\therefore \text{Rotor copper loss} = I_2^2 R = I_2^2 \times 0.4.$$

For the induction motor:

Rotor copper loss = $S \times$ Rotor input.

$$I_2^2 \times 0.4 = 0.04 \times P. \quad (i)$$

Slip at $N_2 = 800$ rpm is:

$$= \frac{1,000 - 800}{1,000} = 0.2.$$

Let new rotor resistance be R^1 in rotor circuit:

$$\text{New copper loss} = I_2^2 R^1$$

$$\frac{I_2^2 R^1}{P} = 0.2 \quad (\text{ii})$$

$$\frac{I_2^2 R^1 \times 0.04}{I_2^2 \times 0.4} = 0.2$$

$$R^1 = \frac{0.2 \times 0.4}{0.04} = 2\Omega.$$

The external resistance to be added in the rotor circuit is:

$$R_{\text{ext}} = R^1 - R$$

$$= 2 - 0.4 = 1.6 \Omega.$$

Example 8.26: The rotor resistance and the reactance at stand-still condition of a 3- ϕ , six-pole, and 440-V induction motor are 0.2 Ω and 1.0 Ω , respectively, per phase. Calculate the starting current, and when the speed is 960 rpm, the frequency of the supply is 50 Hz.

Solution:

Rotor resistance per phase = 0.2 Ω .

Rotor reactance per phase = 1.0 Ω .

$$\text{Synchronous speed } N_s = \frac{120f}{P} = \frac{120 \times 50}{6} = 1,000 \text{ rpm.}$$

The slip of the induction motor
$$S = \frac{N_s - N_r}{N_s} = \frac{1,000 - 960}{1,000} = 0.04.$$

At the time of starting $S = 1$.

$$\begin{aligned} \therefore \text{Rotor current per phase } (I_2) &= \frac{V_{\text{ph}}}{R_2^2 + X_2^2} \\ &= \frac{440/\sqrt{3}}{\sqrt{(0.2)^2 + 1^2}} = 249.05 \text{ A.} \end{aligned}$$

At a speed of 960 rpm, the rotor resistance per phase is:

$$\begin{aligned} R_2^1 &= \frac{R_2}{S} = \frac{0.2}{0.04} = 5 \Omega. \\ \therefore \text{The rotor current per phase, } I_2^1 &= \frac{440/\sqrt{3}}{\sqrt{5^2 + 1^2}} \\ &= \frac{254.034}{\sqrt{26}} = 49.82 \text{ A.} \end{aligned}$$

Example 8.28: The open circuit voltage across the slip rings of a 100-HP induction motor is 280 volts at standstill. What resistance in rotor circuit will reduce its full-load speed by 20%. The full-load slip is 3% with no additional rotor resistance. Assume rotor to be star-connected. And full-load slip $S_1 = 0.03$.

Solution:

The mechanical power developed by the rotor:

$$\begin{aligned} P_{\text{mech}} &= 100 \times 735.5 \\ &= 73,550 \text{ W.} \end{aligned}$$

The standstill induced emf per phase in rotor:

$$E_2 = \frac{280}{\sqrt{3}}$$

$$= 161.65 \text{ V.}$$

The rotor current per phase $I_2 = \frac{S_1 E_2}{R_2}$ (X_2 is neglected)

$$= \frac{0.03 \times 161.65}{R_2}$$

$$= \frac{4.85}{R_2}.$$

The mechanical power developed by the rotor is:

$$= \frac{\text{Total rotor copper loss}}{S} \times (1 - S)$$

$$73,550 = \frac{3I_2^2 R_2}{0.03} \times (1 - 0.03)$$

$$= 97 I_2^2 R_2.$$

Substituting $I_2 = \frac{4.05}{R_2}$ value in the above expression.

$$= 97 \left(\frac{4.05}{R_2} \right)^2 R_2$$

$$73,550 = \frac{2,281.68}{R_2}$$

$$R_2 = 0.03 \Omega.$$

The new speed $N_2 = N_s (1 - 0.03) (1 - 0.2)$

$$N_2 = 0.776 N_s.$$

$$\text{Slip } S_2 = \frac{N_s - N_2}{N_s} = \frac{N_s - 0.776N_s}{N_s}$$

$$S_2 = 0.224.$$

The load torque is assumed to be constant.

$S \propto$ rotor resistance

$$\frac{S_2}{S_1} = \frac{R_2 + R}{R_2}$$

$$\frac{.224}{0.03} = \frac{0.03 + R}{0.03}$$

$$R = 0.193 \Omega.$$

Example 8.29: A eight-pole, 50-Hz, and 3- ϕ induction motor is running at 4% slip when delivering full-load torque. It has a standstill rotor resistance of 0.3 Ω and a reactance of 0.8 Ω per phase. Calculate the speed of the motor if an additional resistance of 0.3 Ω per phase is inserted in the rotor circuit. The full-load torque remains constant.

Solution:

$$\begin{aligned} \text{The synchronous speed of the motor } N_s &= \frac{120f}{P} \\ &= \frac{120 \times 50}{8} \\ &= 750 \text{ rpm.} \end{aligned}$$

Full-load slip $S_1 = 0.04$.

The motor torque $T = \frac{KSR_2E_2^2}{R_2^2 + S^2X_2^2}$.

At full load, the new slip is S_1 then:

$$\begin{aligned}T_1 &= \frac{KS_1R_2E_2^2}{R_2^2 + S_1^2X_2^2} \\&= \frac{K \times 0.04 \times 0.3 \times E_2^2}{(0.3)^2 + (0.04 \times 0.8)^2} \\&= KE_2^2(0.1318).\end{aligned}$$

$$\begin{aligned}T_2 &= \frac{KS_2(R_2 + R)E_2^2}{(R_2 + R)^2 + (S_2X_2)^2} \\&= \frac{KS_2(0.3 + 0.3)E_2^2}{(0.3 + 0.3)^2 + (0.8S_2)^2} \\&= \frac{0.6KS_2E_2^2}{0.36 + 0.64S_2^2}.\end{aligned}$$

The two torques are remains same i.e., $T_1 = T_2$:

$$0.1318 = \frac{0.6S_2}{0.36 + 0.64S_2^2}$$

$$0.0474 + 0.084S_2^2 = 0.6S_2$$

$$0.084S_2^2 - 0.6S_2 + 0.0474 = 0$$

$S_2 = 0.079$ neglecting higher values.

$$\begin{aligned}\therefore \text{The speed of motor } N_2 &= N_s (1 - S) \\ &= 750 (1 - 0.079) \\ &= 690.75 \text{ rpm.}\end{aligned}$$

Example 8.31: The rotor of a six-pole, 50-Hz, and 3- ϕ induction motor has a resistance of 0.3 Ω per phase and runs at 960 rpm. If the load torque remains unchanged, calculate the additional rotor resistance that will reduce the speed by 20%.

Solution:

$$\begin{aligned}\text{The synchronous speed of the motor, } N_s &= \frac{120f}{P} \\ &= \frac{120 \times 50}{6} \\ &= 1,000 \text{ rpm.}\end{aligned}$$

Full-load speed = 960 rpm.

$$\begin{aligned}\text{Full-load slip } S_1 &= \frac{N_s - N_1}{N_s} = \frac{1,000 - 960}{1,000} \\ &= 0.04.\end{aligned}$$

$$\begin{aligned}\text{New speed } N_2 &= N_1 (1 - 0.2) \\ &= 960 \times 0.8 \\ &= 768 \text{ rpm.}\end{aligned}$$

$$\begin{aligned}\text{New slip } S_2 &= \frac{N_s - N_2}{N_s} \\ &= \frac{1,000 - 768}{1,000} \\ &= 0.232.\end{aligned}$$

For the constant load torque:

$$S \propto R_2$$

$$\frac{S_2}{S_1} = \frac{R_2 + R}{R_2}$$

$$\frac{0.232}{0.04} = \frac{0.3 + R}{0.3}$$

$$R = 1.44 \Omega.$$

Example 8.32: A cascade it consists of two motors A and B with four and six poles, respectively. The motor is connected to a 50-Hz supply. Find (i) the speed of the set and (ii) the electric power transferred to motor B when the input to motor A is 30-kW neglect losses.

Solution:

$$\begin{aligned} \text{The synchronous speed of the test, } N &= \frac{120 \times f}{P_A + P_B} = \frac{120 \times 50}{4 + 6} \\ &= 600 \text{ rpm.} \end{aligned}$$

$$\begin{aligned} \text{The power output of motor } B &= P \times \frac{P_B}{P_A + P_B} \\ &= 30 \times \frac{6}{4 + 6} \\ &= 18 \text{ kW.} \end{aligned}$$

\therefore The outputs of the two motors are proportional to the number of their poles.

RATING OF MOTOR

The selection of motor for particular drive application based on the size of motor depends upon the following two factors:

1. Maximum temperature raise for a given load.
2. Maximum torque required.

The size of motor and its rating are mainly dependent upon the raise in temperature. The temperature raise in turn depends upon the type of insulation used.

Temperature raise of motor

The various losses takes place in any motor will be converted into heat. The heat thus produced will increase the temperature of various parts of the motor. The increase in temperature is mainly dependent on the following two factors:

1. Amount of heat developed internally at uniform rate.
2. The amount of heat dissipated from the surface of the motor.

In fact, the continuous rating of a machine is that rating for which the final temperature raise is equal to or just below the permissible value of the temperature raise for the insulating material used in protection of motor windings. When the machine is overloaded for such a long time that its final temperature raise exceeds the permissible limit, it is likely to be damaged. Sometimes, it will results immediate breakdown of insulating material which will cause a sudden short circuit in the motor, which may also lead to a fire. Since temperature raise is one of the chief features in fixing the size of motor. The temperature raise will be high in the beginning and will decrease gradually with the passage of time and finally the temperature of the motor attains a steady-state value. At this point, the heat produced and dissipated will be equal.

The above circumstances make the heating calculations very complex and practically impossible unless certain assumptions are made as:

1. Heat developed, i.e., losses remains constant during temperature raise.
2. The heat dissipation is directly proportional to the difference in the temperature of motor and cooling medium, i.e., Newton's law of cooling hold's good.
3. The temperature of cooling medium remains unchanged.
4. The motor is assumed to be a homogeneous mass having the same and uniform temperature in all parts. It implies high thermal conductivity.
5. For the determination of an expression for the temperature raise of an electrical machine after time ' t ' seconds from the instance of switching it on.

Let P is the electrical power converted into heat (W or J/sec), M is the mass of active parts of motor (kg), S is the specific heat of material (J/kg/°C), O is the temperature raise above the

cooling medium or ambient temperature ($^{\circ}\text{C}$), A is the surface area of cooling, (m^2), θ_f is the final temperature raise with constant load ($^{\circ}\text{C}$), and λ is the coefficient of cooling or the rate of heat dissipation ($\text{W}/\text{m}^2/^{\circ}\text{C}$ raise).

Now, let us assume that the machine attains a temperature raise of $\theta^{\circ}\text{C}$ above ambient temperature after ' t ' seconds of switching on the machine and further raise of temperature by $d\theta$ in very small time ' dt ' seconds.

The rate at which the loss takes place or the heat is absorbed by the motor $= MS \frac{d\theta}{dt}$ J/sec.

The rate at which heat is dissipated $= A\theta\lambda$ J/sec.

But, the rate at which the electrical power converted into heat = the rate at which the heat is absorbed + the rate at which the heat dissipated by the motor.

$$P = MS \frac{d\theta}{dt} + A\lambda\theta \quad (8.29)$$

$$P - A\theta\lambda = MS \frac{d\theta}{dt}$$

$$dt = \frac{MSd\theta}{P - A\theta\lambda} \quad (8.30)$$

Integrating the Equation (8.30):

$$\int dt = \int \frac{MS}{P - A\theta\lambda} d\theta$$

$$t = MS \log_e (P - A\theta\lambda) \times \left(\frac{-1}{A\lambda} \right) + K, \quad (8.31)$$

where K is the integration constant.

Initially, at time $t = 0$ sec, temperature raise $\theta = 0^{\circ}\text{C}$.

By substituting $t = 0$ and $\theta = 0$ in Equation (8.31), we get the integration constant (K):

$$\text{i.e., } 0 = \frac{-MS}{A\lambda} \log_e(P-0) + K$$

$$\text{or } K = \frac{MS}{A\lambda} \log_e P.$$

Substituting the value of 'K' in Equation (8.31), we get:

$$t = \frac{-MS}{A\lambda} \log_e(P - A\lambda\theta) + \frac{MS}{A\lambda} \log_e P \quad (8.32)$$

$$= \frac{-MS}{A\lambda} [\log_e(P - A\lambda\theta) - \log_e P]$$

$$= \frac{-MS}{A\lambda} \log_e \left[\frac{P - A\lambda\theta}{P} \right]$$

$$\therefore \frac{-A\lambda t}{MS} = \log_e \left[\frac{P - A\lambda\theta}{P} \right].$$

By applying exponential on both side, we get:

$$e^{\frac{-A\lambda t}{MS}} = 1 - \frac{A\lambda\theta}{P} \quad [\because \log_e e = 1]$$

$$\frac{A\lambda\theta}{P} = 1 - e^{\frac{-A\lambda t}{MS}}$$

$$\theta = \frac{P}{A\lambda} \left(1 - e^{\frac{-A\lambda t}{MS}} \right). \quad (8.33)$$

When 't' is infinity, 'θ' approaches to its final steady-state temperature 'θ_f'. So, by substituting $t = \infty$ and $\theta = \theta_f$ in Equation (8.33), we get:

$$\begin{aligned}\theta_f &= \frac{P}{A\lambda} [1 - e^{-\infty}] \\ &= \theta_f \left[1 - e^{-\frac{t}{T_h}} \right],\end{aligned}\tag{8.35}$$

Substituting $\theta_f = \frac{P}{A\lambda}$ in Equation (8.33), we get:

$$\begin{aligned}\theta &= \theta_f \left[1 - e^{-\frac{A\lambda}{MS} t} \right] \\ &= \theta_f \left[1 - e^{-\frac{t}{T_h}} \right],\end{aligned}\tag{8.35}$$

where ' T_h ' = $\frac{MS}{A\lambda}$ is known as heating time constant of motor.

The above relation is the equation of temperature rise with time. The temperature raise time curve or heating curve is exponential in nature as shown in Fig. 8.29.

From the equation of temperature raise:

$$\theta = \theta_f \left[1 - e^{-\frac{t}{T_h}} \right].$$

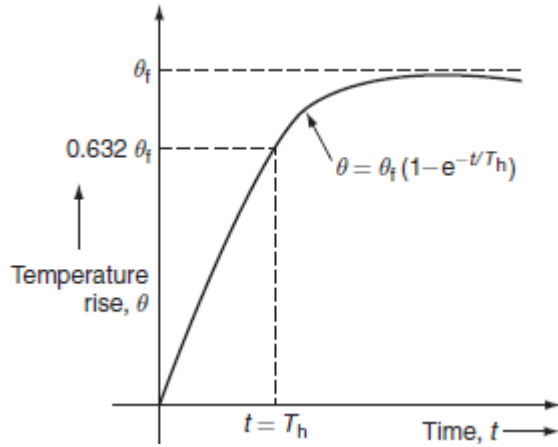

Fig. 8.29 Heating curve

$$\text{At } t = T_h, \theta = \theta_f [1 - e^{-1}]$$

$$\therefore \theta = 0.632 \theta_f.$$

Thus, *heating time constant* can be defined as follows:

The heating time constant is the time taken by the machine to attain 63.2% of its final steady temperature raise (θ_f).

The heating time constant of the conventional electrical machines is usually within the range of 0.5–3 for 4 h.

Cooling of motor

Let us assume, if the supply to the motor is switched off, after attaining the final steady temperature raise of ' θ_f ', the motor starts cooling. When the machine is switched off, no heat is produced, therefore:

$$\text{Heat absorbed} + \text{heat dissipated} = 0$$

$$\therefore MS \frac{d\theta}{dt} + A\lambda' \theta = 0, \quad (8.36)$$

where λ = heat dissipation during cooling of motor.

$$MS d\theta + A\lambda' \theta \cdot dt = 0$$

$$dt = -\frac{MS}{A\lambda'} d\theta. \quad (8.37)$$

Integrating the Equation (8.37):

$$\int dt = \frac{-MS}{A\lambda'} \int d\theta$$

$$t = \frac{-MS}{A\lambda'} \log_e \theta + K^1, \quad (8.38)$$

where K^1 is the integration constant.

The value of K_1 is obtained by using the initial conditions, when $t = 0$ and $\theta = \theta_i$, we get:

$$0 = \frac{-MS}{A\lambda'} \log_e \theta_i + K^1$$

$$K^1 = \frac{MS}{A\lambda'} \log_e \theta_i. \quad (8.39)$$

Substituting Equation (8.39) in Equation (8.38):

$$\begin{aligned}
t &= \frac{-MS}{A\lambda^1} \log_e \theta + \frac{MS}{A\lambda^1} \log_e \theta_f \\
&= \frac{-MS}{A\lambda^1} [\log_e \theta - \log_e \theta_f] \\
&= \frac{-MS}{A\lambda^1} \log_e \left(\frac{\theta}{\theta_f} \right) \\
\therefore \frac{-A\lambda^1 t}{MS} &= \log_e \left(\frac{\theta}{\theta_f} \right).
\end{aligned}$$

Applying exponentials on both side λ :

$$\begin{aligned}
e^{\frac{-A\lambda^1 t}{MS}} &= \log_e e^{\left(\frac{\theta}{\theta_f} \right)} \quad [\because \log_e e^x = x] \\
\frac{\theta}{\theta_f} &= e^{\frac{-A\lambda^1 t}{MS}} \\
&= \theta_f e^{\frac{-A\lambda^1 t}{MS}} \\
&= \theta_f e^{\frac{-t}{T_c}}, \tag{8.40}
\end{aligned}$$

where $T_c = \frac{MS}{A\lambda^1}$ is know as cooling time constant.

The above relation is the equation of cooling of motor. The cooling curve is exponentially decaying in nature as shown in Fig. 8.30.

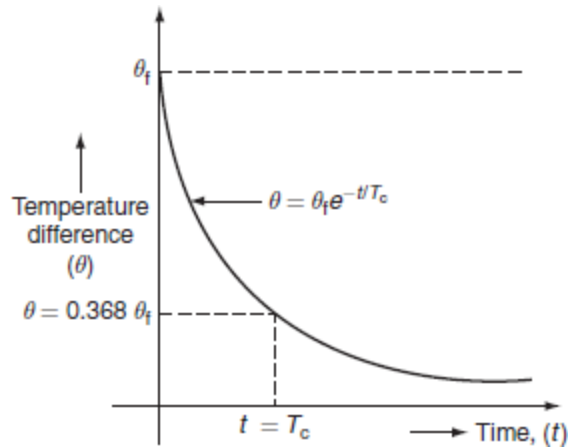

Fig. 8.30 Cooling curve

From the cooling equation, at time $t = T_c$:

We have $\theta = \theta_i (e^{-1})$

$$\therefore \theta = 0.368\theta_i.$$

Thus, we can define the *cooling time constant* as:

The cooling time constant is defined as the time required cooling the machine down to 36.8% of the initial temperature raise above the ambient temperature.

The heating and cooling curves follows an exponential law. Heating time constant and cooling time constant may be different for the same machine and also the cooling time constant of rotating machine is larger than its heating time constant, due to poorer ventilation conditions when the machine cools.

Figure 8.31 (a) and (b) shows the heating and cooling curves of a motor for short-time and intermittent loads.

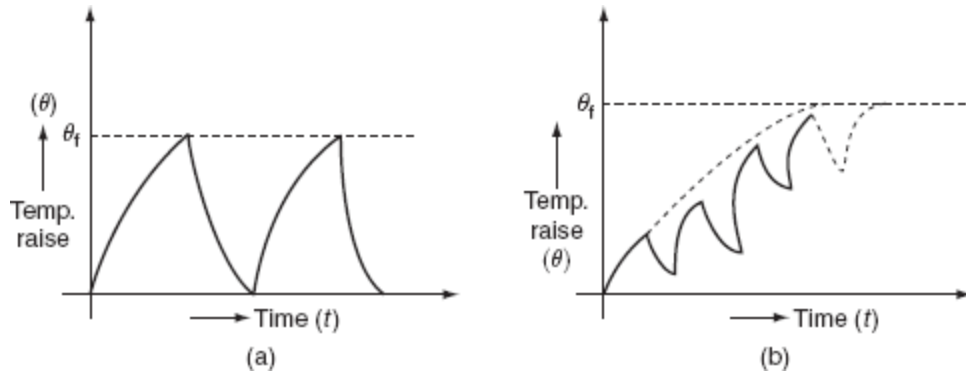

Fig. 8.31 (a) Short-time load motor (b) intermittent-time load motor

Example 8.33: An induction motor has a final steady-state temperature raise of 50°C when running at its rated output. Calculate its half-hour rating for the same temperature raise if the copper losses at the rated output are 1.5 times its constant losses. The heating time constant is 60 min.

Solution:

Given data:

Final steady temperature $(\theta_f) = 50^{\circ}\text{C}$.

Time constant $(\tau_h) = 60$ min.

$$\text{Rating}(t) = \frac{1}{2} \text{ hour} = 30 \text{ min.}$$

And, the copper loss = $1.5 \times$ constant loss

$$\text{i.e., } W_{\text{cu}} = 1.5 \times W_i$$

let ' P ' be the rated output,

$$\text{Total loss at full load} = W_{\text{cu}} + W_i.$$

But, the temperature raise is proportional to the losses.

$$\therefore \theta \propto W_{\text{loss}}.$$

Let, θ_f be the temperature raise at full load.

θ_f^1 be the temperature raise with short-time rating.

$$\begin{aligned}
\therefore \frac{\theta_f}{\theta_f^1} &= \frac{W_{cu} + W_i}{x^2 W_{cu} + W_i} \\
&= \frac{1.5 \times 1 + 1}{(1.5)x^2 + 1} \quad [\because W_{cu} = 1.5 W_i] \\
&= \frac{2.5}{1.5x^2 + 1} \quad \text{(i)}
\end{aligned}$$

The temperature raise after 30 min of operation should not exceed $\theta_f = 50^\circ\text{C}$.

Now, from the equation of temperature raise of motor:

$$\begin{aligned}
\theta_f &= \theta_f^1 (1 - e^{-t/\tau_m}) \\
50 &= \theta_f^1 (1 - e^{-30/60}) = \theta_f^1 (1 - 0.606) \\
&= \theta_f^1 \times 0.393. \\
\therefore \theta_f^1 &= 128.07^\circ\text{C}.
\end{aligned}$$

Substitute ' θ_f^1 ' in Equation (i):

$$\begin{aligned}
\frac{\theta_f}{\theta_f^1} &= \frac{2.5}{1.5x^2 + 1} \\
\theta_f^1 &= \theta_f \times \left(\frac{1.5x^2 + 1}{2.5} \right)
\end{aligned}$$

$$1.5x^2 = 6.3537$$

$$x^2 = 4.235$$

$$\therefore x = 2.058.$$

∴ Hence, the half-hour rating of machine is 2.058 times its continuous rating.

Example 8.34: A 10-kW motor has a heating time constant and cooling time constant of 45 and 70 min, respectively. The final temperature attained is 60°C. Find the temperature of motor after 45 min full-load run and then switched off for 30 min.

Solution:

Given data:

$$\tau_h = 45 \text{ min}$$

$$\tau_c = 70 \text{ min}$$

$$\theta_f = 60^\circ\text{C}$$

$$t = 45 \text{ min.}$$

We know that:

$$\begin{aligned}\theta &= \theta_f (1 - e^{-t/\tau_h}) \\ &= 60 (1 - e^{-45/45}) \\ &= 60 \times 0.632 = 37.927^\circ\text{C}.\end{aligned}$$

When the motor is switched off for 30 min, the temperature is:

$$\begin{aligned}\theta &= \theta_f e^{-t/\tau_c} \\ &= 37.927 e^{-30/70} \\ &= 37.927 \times 0.6514 = 24.707 \cong 25^\circ\text{C}.\end{aligned}$$

Example 8.35: The heating time constant of a 80-kW motor is 60 min. The temperature raise is 65°C when runs continuously on full load. Find the half-hour rating of motor for the same

temperature raise. Assume that the losses are proportional to the square of the load and the motor cools to ambient temperature between each load cycle.

Solution:

Let 'x' be the half-hour rating in kW.

$$\text{Losses at half-hour rating} = \left(\frac{x}{80}\right)^2 \times \text{losses at 80 kW.}$$

Let θ is the temperature raise at x kW and θ_f is the temperature raise at 80 kW. We know that the losses \propto load² and temperature raise \propto losses

$$\frac{\theta}{\theta_f} = \left(\frac{x}{80}\right)^2$$

$$\therefore \theta = \theta_f \times \left(\frac{x}{80}\right)^2$$

$$\therefore \theta = 65 \times \left(\frac{x}{80}\right)^2.$$

$$\begin{aligned} \text{Now, } 65 &= \theta(1 - e^{-t/\tau_h}) \\ &= 65 \left(\frac{x^2}{80}\right) (1 - e^{-30/60}). \end{aligned}$$

$$0 = \frac{x^2}{80} (1 - e^{-1/2})$$

$$6,400 = x^2 (1 - e^{-0.5}) = x^2 (0.393)$$

$$\begin{aligned} x &= \sqrt{\frac{6400}{0.393}} \\ &= 127.5 \text{ kW.} \end{aligned}$$

Example 8.36: The heating time constant and final steady temperature of a motor on continuous running is 60 min and 40°C. Find out the temperature (i) after 25 min at this load, (ii)

after 45 min at this load, (iii) if the temperature raise at half-hour rating is 40°C, find the maximum steady temperature, (iv) what will be the time required to increase the temperature from 25°C to 40°C at one-and-half-hour rating.

Solution:

Given data:

$$\theta_f = 40^\circ\text{C}$$

$$t = 25 \text{ min}$$

$$\tau_h = 60 \text{ min.}$$

1. We know that:

$$\begin{aligned}\theta &= \theta_f (1 - e^{-t/\tau_h}) \\ &= 60 (1 - e^{-25/60}) \\ &= 60 \times 0.340 = 20.44^\circ\text{C}.\end{aligned}$$

2. For 45 min at the same load:

$$\begin{aligned}\theta &= \theta_f (1 - e^{-t/\tau_h}) \\ &= 60 (1 - e^{-45/60}) \\ &= 31.658^\circ\text{C}.\end{aligned}$$

3. If the temperature raise is 40°C after half an hour, the maximum temperature:

$$\begin{aligned}\therefore \theta_f &= \frac{\theta}{(1 - e^{-t/\tau_h})} = \frac{40}{1 - e^{-30/60}} \\ &= \frac{40}{1 - e^{-1/2}} = 101.65^\circ\text{C}.\end{aligned}$$

4. Given, time taken to attain temperature raise of 40°C is one-and-half hour. Then, the maximum temperature θ_f is 101.65°C.

Let 't' be the taken in min needed to raise the temperature from 25°C to 40°C.

$$\theta = \theta_f (1 - e^{-t/\tau_h})$$

$$25 = 40(1 - e^{-t/60})$$

$$0.625 = (1 - e^{-t/60})$$

$$e^{-t/60} = 0.375$$

$$-t/60 = \ln(0.375) = -0.98$$

$$\therefore t = 60 \times 0.98 = 58.84^\circ\text{C}.$$

Thus, the temperature will increase from 25°C to 40°C in time, $t^1 = 90 - 58.84 = 31.15$ min.

Example 8.37: The heating time constant of a motor is 90 min with 1-hr rating as 200 W. The maximum efficiency of motor occurs at 80% of full load. Determine the continuous rating of the motor.

Solution:

Given that, the maximum efficiency occurs at 80% of full load. Therefore, at 80% of full load, the copper loss is equal to the iron loss.

Let iron loss = copper loss = W_c W.

Copper loss at 80% of full load = W_c .

$$\text{Copper loss at full load} = \left(\frac{1}{0.8}\right)^2 \times W_c.$$

$$\begin{aligned} \text{Losses at full load} &= W_c + \left(\frac{1}{0.8}\right)^2 \times W_c \\ &= W_c \left(1 + \left(\frac{1}{0.8}\right)^2\right) \\ &= 2.5625 W_c. \end{aligned}$$

$$\text{Losses at load of 200 W} = W_c + \left[\frac{200}{0.8 + \text{full load}} \right]^2 \times W_c.$$

θ_f = Total loss on full load.

θ_f^1 = Total loss on 30 min rating.

$$\frac{\theta_f^1}{\theta_f} = \frac{1}{1 - e^{-t/\tau_h}} = \frac{\text{total loss on 30 min rating}}{\text{total loss on full load}}$$

$$\frac{1}{1 - e^{-60/90}} = \frac{W_c + \left[\frac{200}{0.8 \times \text{full load}} \right]^2 \times W_c}{2.5625 W_c}$$

$$2.055 = \frac{1 + \left(\frac{250}{\text{full load}} \right)^2}{2.5625}$$

$$5.265 = 1 + \left(\frac{250}{\text{full load}} \right)^2$$

$$\frac{250}{\text{full load}} = 4.265$$

$$\therefore \text{Full load} = \frac{250}{2.065} = 121.04 \text{ W.}$$

TYPES OF LOADS

While selecting a motor, in addition to the information of load–speed–torque characteristics, the variation of load torque, losses, and temperature raise with time is also needed. In case the load and torque verses time variation is periodic and repetitive, such one cycle of variation of load with time is known as load or *duty cycle*. The various types of loads that occur in industrial practice can be classified depending upon their variation with time and duty cycle, which can be specified by the load diagram.

Figure 8.32 shows the typical duty cycle or load cycle which will give the variation of load with time and also the type of load.

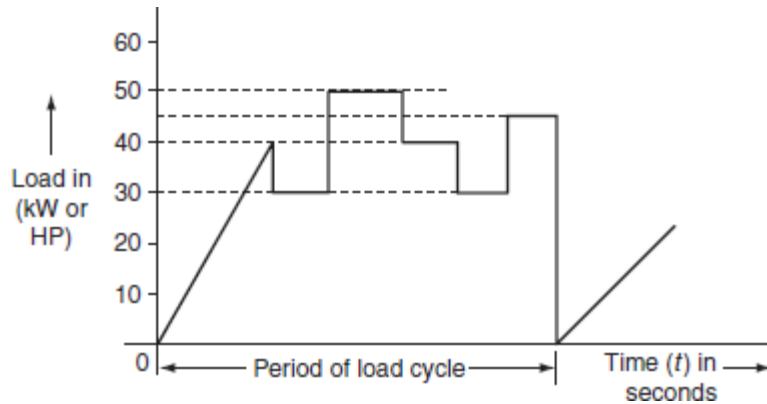

Fig. 8.32 Duty cycle or load cycle

Classification of loads with respect to time

The loads are classified with respect to time as follows.

Continuous and constant loads

The loads on the motor operate for a long time under the same conditions.

Ex: fan, compressors, conveyors, centrifugal pumps, etc.

Continuous and variable loads

The load on the motor operates repetitively for a longer duration but varies continuously over a period.

Ex: metal cutting lathes, hoist winches, conveyors, etc.

Pulsating loads

The load on the motor which can be viewed as constant torque superimposed by pulsations.

Ex: tile looms, reciprocating pumps, certain type of loads with crankshaft, frame saws, etc.

Impact loads

The load on the motor having regular and repetitive load peaks or pulses, i.e., load increases to a maximum level suddenly.

Ex: rolling mills, shearing machines, etc.

Short-time intermittent loads

The load on the motor occurs periodically in identically duty cycle, each duty cycle having a period of application of load and rest.

Ex: Roller trains, cranes, hoisting mechanisms, etc.

Short-time loads

The load on the motor occurs periodically remains constant for short time and then remains idle or off for longer time.

Ex: servomotors, motor-generator sets, used for charging batteries, drilling machines, etc.

8.10.2 Classification of loads with respect to duty cycle

There are three basic classifications of duties of an electric motor. They are:

1. Continuous duty cycle.
2. Short-time duty cycle.
3. Intermittent duty cycle.

Continuous duty cycle

Continuous duty is the duty when the on-period is so long that the motor attains a steady-state temperature raise. The motor so selected should be able to withstand momentary overload capacity. This type of motors will have high efficiency because they will be operating almost at its full load and also have good power factor.

There are mainly two types of continuous duty cycle. They are:

1. Continuous duty at constant load cycle.
2. Continuous duty at variable load cycle.

In continuous duty with constant load cycle, the load torque remains constant for a sufficiently longer period. The variation of torque against time for continuous duty is shown in [Fig. 8.33](#).

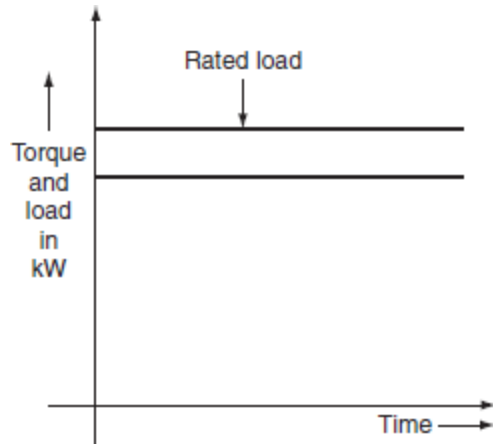

Fig. 8.33 Continuous duty with constant load

Ex: Conveyors, compressors, fan, etc. in which continuous duty at constant load occurs.

In continuous duty with variable load cycle, the load on the motor is not constant, but it has several phases in one cycle. The variation of load against time for variable load cycle is shown in Fig. 8.34. The selection of motor for this type of duty involves thermal calculation, which is a difficult task. The motors operating for such type of duties will have poor efficiency and also poor power factor.

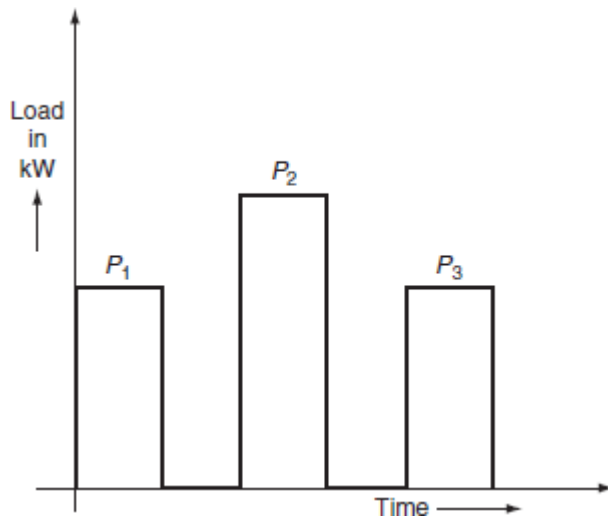

Fig. 8.34 Continuous duty with variable load

The selection of motor for this type of duty may be based on average power or average current method.

Short-time duty

In this type of duty, the load occurs on the motor during a small interval and the remains idle for long time to re-establish the equality of temperature with the cooling medium. The variation of the load against time for short-time duty is shown in Fig. 8.35.

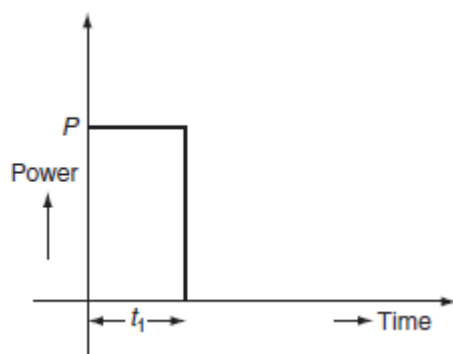

Fig. 8.35 Load cycle for short time duty

Usually, such type of short-time duty occurs in bridges, lock gates, and some other household appliances such as mixies.

Intermittent duty

The duty in which load on the motor varies periodically in a sequence of identical cycles shown in Fig. 8.36, in which motor is loaded for sometimes ' t_{on} ' and shut off for a period of ' t_{off} '.

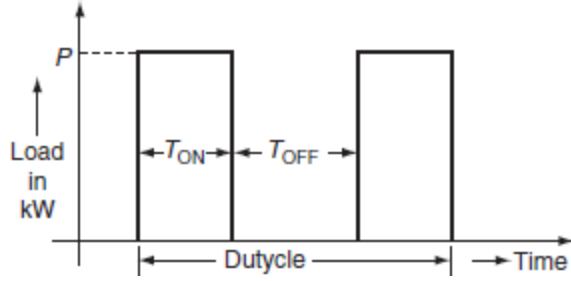

Fig. 8.36 Load cycle for intermittent duty

Motor heats during 'on' period ' t_{on} ' and cools down during 'off' period ' t_{off} '. The ratio of ' t_{on} ' to $(t_{on} + t_{off})$ is known as *duty ratio*.

$$\text{Duty ratio} = \frac{t_{on}}{(t_{on} + t_{off})}$$

Maximum temperature attained with intermittent loading can be obtained by using the temperature raise and cooling equations of motor, and is given as follows.

Let $\theta_h, \theta_n^1, \theta_n^2, \dots, \theta_n^{n-1}$ be the temperature raise and $\theta_c, \theta_c^1, \theta_c^2, \dots, \theta_c^{n-1}$ be the fall in temperature for ' n ' times intermittency.

Let t_1 be the duration of heating in second, t_2 be the duration of cooling in second, τ_n be the heating time constant in second, τ_c be the cooling time constant in second, and θ_f be the maximum permissible temperature raise of motor.

$$\begin{aligned} \text{During on time: } \theta_h &= \theta_f (1 - e^{(-t_1/\tau_n)}) \\ \theta_h &= \theta_f (1 - e^x), \end{aligned}$$

$$\text{where } x = \frac{-t_1}{\tau_n} \quad (8.41)$$

During off time $\theta_c = \theta_h e^{-t_2/\tau_c} = \theta_h e^y$, (8.42)

where $y = \frac{-t_2}{\tau_c}$

Substituting Equation (8.41) in Equation (8.42):

We get $\theta_c = \theta_f (1 - e^x)e_y$. (8.43)

Similarly, for the next intermittent loading:

During time: $\theta_h^1 = \theta_f - \{(\theta_f - \theta_c)e^x\}$
 $= \theta_f(1 - e^x) + \theta_c e^x$
 $= \theta_f(1 - e^x) + \{\theta_f(1 - e^x) \cdot e^y\} \cdot e^x$ [\because from Equation (8.41)]
 $\therefore \theta_h^1 = \theta_f(1 - e^x)[1 + e^x \cdot e^y]$. (8.44)

During 'off' time: $\theta_c^1 = \theta_h^1 \cdot e^y$

$\theta_c^1 = \{\theta_f(1 - e^x)(1 + e^x \cdot e^y)\} \cdot e^y$. (8.45)

Similarly, for the next 'on' and 'off' periods:

During 'on' time: $\theta_h^2 = \theta_f - \{(\theta_f - \theta_c^1)e^x\}$

$$\begin{aligned}
&= \theta_f(1 - e^x) + \theta_c^1 e^x \\
&= \theta_f(1 - e^x) + \{\theta_f(1 - e^x)(1 + e^x \cdot e^y)\} e^y \cdot e^x \\
&\quad [\because \text{form equation (7.47)}] \\
&= \theta_f(1 - e^x)[1 + (e^x \cdot e^y + e^{2x} \cdot e^{2y})] \\
&= \theta_f(1 - e^x)[1 + (e^x \cdot e^y + e^{2x} \cdot e^{2y})] \quad (8.46)
\end{aligned}$$

During 'off' time: $\theta_c^2 = \theta_h^2 e^y$

$$\begin{aligned}
&= \theta_f \cdot (1 - e^x) (1 + e^x \cdot e^y + e^{2x} \cdot e^{2y}) \cdot e^y. \quad (8.47)
\end{aligned}$$

Similarly, for 'n' times intermittency:

$$\begin{aligned}
\theta_h^{n-1} &= \theta_f(1 - e^x) [1 + e^x e^y + e^{2x} \cdot e^{2y} + \dots + e^{(n-1)x} \cdot e^{(n-1)y}] \\
&= \theta_f(1 - e^x) \left[\frac{1 - e^{nx} \cdot e^{ny}}{1 - e^x \cdot e^y} \right]. \quad (8.48)
\end{aligned}$$

As $n \rightarrow \infty$ both e_{nx} and e_{ny} will be zero, as x and y are negative. If ' θ_m ' be the maximum temperature with intermittent loading then:

$$\begin{aligned}
\theta_m &= \theta_f(1 - e^x) \left[\frac{1 - 0}{1 - e^x \cdot e^y} \right] \\
&= \theta_f \left[\frac{1 - 0}{1 - e^x \cdot e^y} \right].
\end{aligned}$$

By substituting x and y values in the above equations:

$$\therefore \theta_m = \theta_f \left[\frac{1 - e^{-t_1/\tau_s}}{1 - e^{[-t_1/\tau_s + t_2/\tau_c]}} \right]. \quad (8.49)$$

RATING OF MOTOR

In cases, where the load fluctuates over a given cycle, as in rolling mills, etc., the rating of motor is determined accurately by finding the heating and cooling curves of motor, when working on given cycle. The various methods for determining the rating of motor for continuous duty and variable load are:

1. Equivalent current method.
2. Equivalent torque method.
3. Equivalent power method.

Equivalent current method

In this method, the actual current may be replaced by an equivalent current method (I_{eq}), which produces the same losses in the motor as the actual current.

$$I_{eq} = \sqrt{\frac{I_1^2 t_1 + I_2^2 t_2 + I_3^2 t_3 + \dots + I_n^2 t_n}{t_1 + t_2 + \dots + t_n}},$$

where $I_1, I_2, I_3, \dots, I_n$ be the load currents within short intervals of t_1, t_2, \dots, t_n over a period of time 'T' seconds (Fig. 8.37).

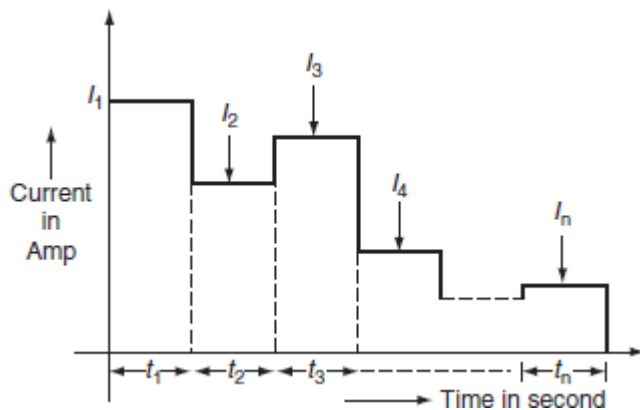

Fig. 8.37 Load cycle for equivalent current method

Equivalent power method

In this method, if the load cycle is given in HP or kW verses time, then the motor rating can be directly found as follows (Fig. 8.38).

$$\text{Motor rating} = \sqrt{\frac{P_1^2 t_1 + P_2^2 t_2 + \dots + P_n^2 t_n}{t_1 + t_2 + \dots + t_n}}$$

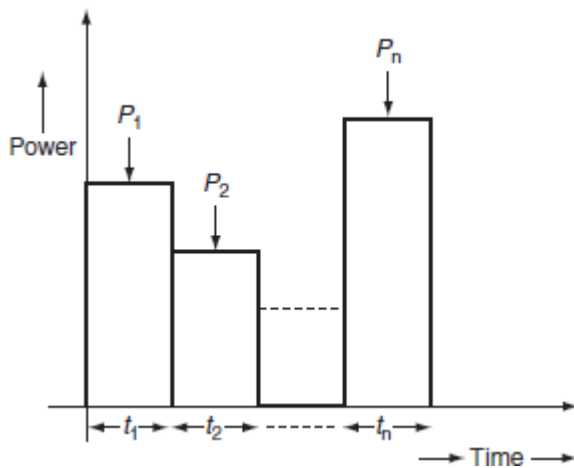

Fig. 8.38 Load cycle for equivalent power method

Load changes uniformly; load cycle varies as shown in Fig. 8.39. The motor rating is given by:

$$\text{Motor rating} = \sqrt{\frac{1/3 P_1^2 t_1 + P_2^2 t_2 + P_0^2 t_3 + P_2^2 t_4 + 1/3 P_5^2 t_5}{t_1 + t_2 + t_3 + t_4 + t_5}}$$

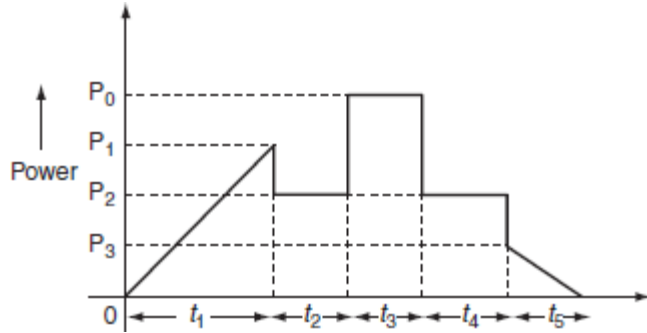

Fig. 8.39 Load cycle for uniform load variation

Note: If the power, load, or torque changes uniformly, then $\int P^2 dt$ has to be taken for that period.

If the load curve consisting of negative power, i.e., power returned to the source, as shown in Fig. 8.40, the motor rating can be directly determined as follows.

$$\text{Motor rating} = \sqrt{\frac{\int_0^{t_1} \left[P_1 + \frac{(P_2 - P_1)}{t_1} t \right]^2 dt + P_1^2 t_2 + P_3^2 t_3 + \int_0^{t_4} \left(\frac{P_4}{t_4} \times t \right)^2 dt}{t_1 + t_2 + t_3 + t_4}}$$

(or)

$$= \sqrt{\frac{\int_0^{t_1} \left[P_1^2 + \frac{(P_2 - P_1)^2}{t_1^2} \times t^2 + \frac{2P_1(P_2 - P_1)}{t_1} \times t \right] dt + P_1^2 t_2 + P_3^2 t_3 + \frac{P_4^2}{t_4^2} \times \frac{t^3}{3} \Big|_0^{t_4}}{t_1 + t_2 + t_3 + t_4}}$$

$$= \sqrt{\frac{\left[P_1^2 t_1 + \frac{(P_2 - P_1)^2}{t_1^2} \frac{t_1^3}{3} + \frac{2P_1(P_2 - P_1)}{t_1} \cdot \frac{t_1^2}{2} \right] + P_1^2 t_2 + P_3^2 t_3 + \frac{P_4^2}{t_4^2} \times \frac{t_4^3}{3}}{t_1 + t_2 + t_3 + t_4}}$$

$$= \sqrt{\frac{\left[P_1^2 t_1 + (P_2 - P_1)^2 \frac{t_1}{3} + (P_1 P_2 - P_1^2) \cdot t_1 \right] + P_1^2 t_2 + P_3^2 t_3 + \frac{P_4^2}{3} t_4}{t_1 + t_2 + t_3 + t_4}}$$

$$= \sqrt{\frac{\left[P_1^2 t_1 + (P_2 - P_1)^2 \frac{t_1}{3} + (P_1 P_2 \cdot t_1 - P_1^2 t_1) \right] + P_1^2 t_2 + P_3^2 t_3 + \frac{P_4^2}{3} t_4}{t_1 + t_2 + t_3 + t_4}}$$

$$\begin{aligned}
&= \sqrt{\frac{\left(P_1^2 + P_2^2 - P_1P_2\right)\frac{t_1}{3} + P_1P_2t_1 + P_1^2t_2 + P_3^2t_3 + \frac{P_4^2}{3}t_4}{t_1 + t_2 + t_3 + t_4}} \\
&= \sqrt{\frac{\left(P_1^2 + P_2^2\right)\frac{t_1}{3} + P_1P_2(1 - 2/3)t_1 + P_1^2t_2 + P_3^2t_3 + \frac{P_4^2}{3}t_4}{t_1 + t_2 + t_3 + t_4}} \\
&= \sqrt{\frac{\left(P_1^2 + P_2^2\right)^2\frac{t_1}{3} + P_1P_2(t_1/3) + P_1^2t_2 + P_3^2t_3 + \frac{P_4^2}{3}t_4}{t_1 + t_2 + t_3 + t_4}} \\
&= \sqrt{\frac{\left(\left(P_1^2 + P_2^2\right)^2 + P_1P_2\right)\frac{t_1}{3} + P_1^2t_2 + P_3^2t_3 + \frac{P_4^2}{3}t_4}{t_1 + t_2 + t_3 + t_4}} \\
&= \sqrt{\frac{\left(P_1^2 + P_1P_2 + P_2^2\right)\frac{t_1}{3} + P_1^2t_2 + P_3^2t_3 + \frac{P_4^2}{3}t_4}{t_1 + t_2 + t_3 + t_4}}.
\end{aligned}$$

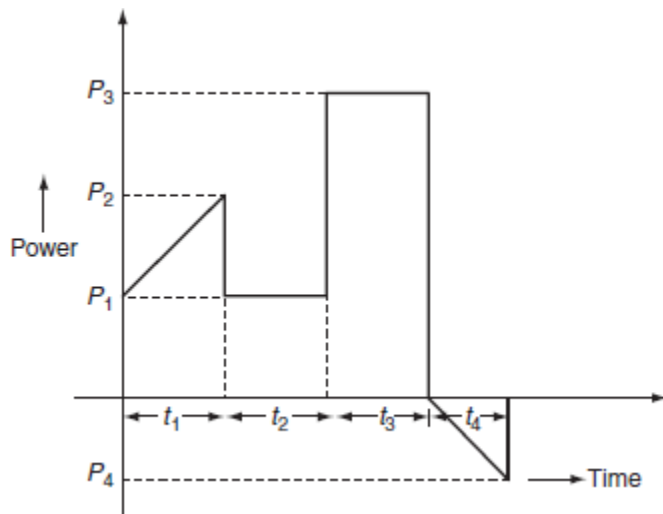

Fig. 8.40 Load cycle for negative power

Equivalent torque method

This method is used to compute the motor heating rating effect, for short time and intermittent loads where the torque is varying as shown in [Fig. 8.41](#).

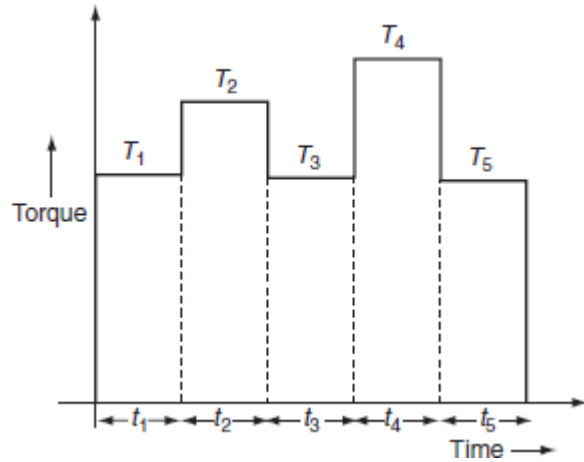

Fig. 8.41 Load cycle for equivalent torque method

In Fig. 8.41, T_1 , T_2 , T_3 , T_4 , and T_5 be the load torques develop during the periods t_1 , t_2 , t_3 , t_4 , and t_5 seconds now the equivalent torque can be calculated by considering time for one complete cycle and RMS value of load torques at different times.

$$\therefore \text{Equivalent torque } (T) = \sqrt{\frac{T_1 t_1^2 + T_2 t_2^2 + T_3 t_3^2 + T_4 t_4^2 + T_5 t_5^2}{t_1 + t_2 + t_3 + t_4 + t_5}}$$

Example 8.38: A motor operates continuously on the following load cycle.

20 kW for 10 sec,

10 kW for 15 sec,

30 kW for 5 sec,

50 kW for 20 sec,

40 kW for 10 sec,

and idle for 5 sec.

Draw the load diagram and find the size of the motor required.

Solution:

The rating of the motor = RMS value of the load (Fig. P.8.8).

$$= \sqrt{\frac{\sum (\text{kW}^2 \times \text{time})}{\text{time for one cycle}}}$$
$$= \sqrt{\frac{20^2 \times 10 + 10^2 \times 15 + 30^2 \times 5 + 50^2 \times 20 + 40^2 \times 10 + 0^2 \times 5}{10 + 15 + 5 + 20 + 10 + 5}} = 34.19 \text{ kW.}$$

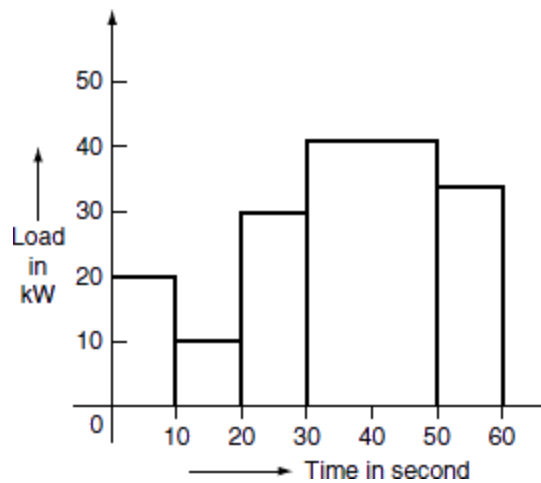

Fig. P.8.8 Load cycle

Example 8.39: The load cycle of a motor in driving some equipment is as follows.

0–3 min 40 kW

3–7 min No-load

7–12 min 30 kW

12–15 min 20 kW

15–18 min 50 kW.

The load repeated indefinitely. Draw the load cycle and suggest suitable continuous rating of the motor.

Solution:

From Fig. P.8.9,

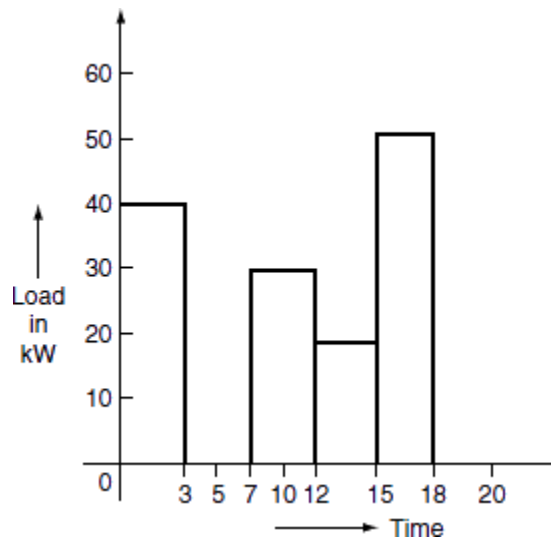

Fig. P.8.9 Load cycle

$$\begin{aligned} \text{Motor rating} &= \sqrt{\frac{(40)^2 \times 3 + 0^2 \times 4 + 30^2 \times 5 + 20^2 \times 3 + 50^2 \times 3}{3 + 4 + 5 + 3 + 3}} \\ &= 31.622 \text{ kW} \cong 32 \text{ kW}. \end{aligned}$$

Example 8.40: A motor has to perform the following load cycle:

Load raising uniformly from 0 to 100 kW in 10 s.

Constant load 300 kW for 5 sec.

Constant load 200 kW for 15 sec.

Regenerative braking power returned falling uniform from 50 to 0 kW in 5 s. Decking period 4 s, motor stationary. Draw the load cycle and suggest a suitable continuous rated motor.

Solution:

From Fig. P.8.10,

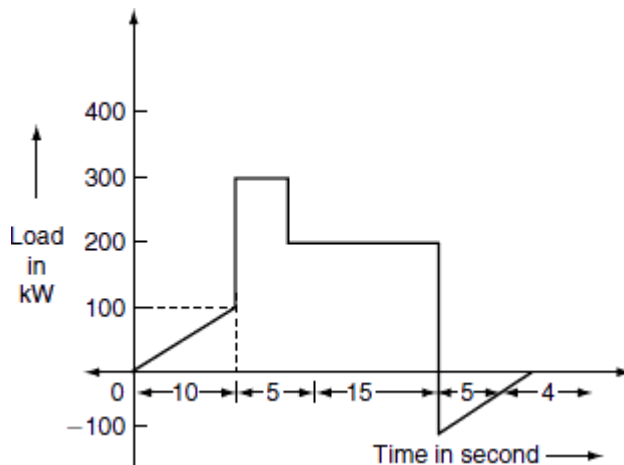

Fig. P.8.10 Load cycle

$$\begin{aligned} \text{Motor rating} &= \sqrt{\frac{1/3 \times 100^2 \times 10 + 300^2 \times 5 + 200^2 \times 15 + \frac{1}{3} \times (-50)^2 \times 5 + 0^2 \times 4}{10 + 5 + 15 + 5 + 4}} \\ &= \sqrt{\frac{1,087,500}{34}} = 178.84 \text{ kW} \cong 179 \text{ kW}. \end{aligned}$$

Example 8.41: A motor has the following load cycle.

Load raising uniformly from 100 to 200 kW in 5 s.

Continuous load 50 kW for 10 s regenerative braking kW returned to the supply 50 kW to 0 kW for 3 s and idle for 2 s.

Draw the load diagram neatly for one cycle. Find the size of continuously rated motor for the above duty. The load cycle is repeated indefinitely.

Solution:

$$(\text{Motor rating})^2 = \frac{\int_0^{t_1} \left[P_1 + \frac{(P_2 - P_1)}{t_1} \cdot t \right]^2 dt + P_3^2 t_2 + \frac{1}{3} P_4^2 t_3 + P_5^2 \times t_4}{T}$$

From the load curve (Fig. P.8.11),

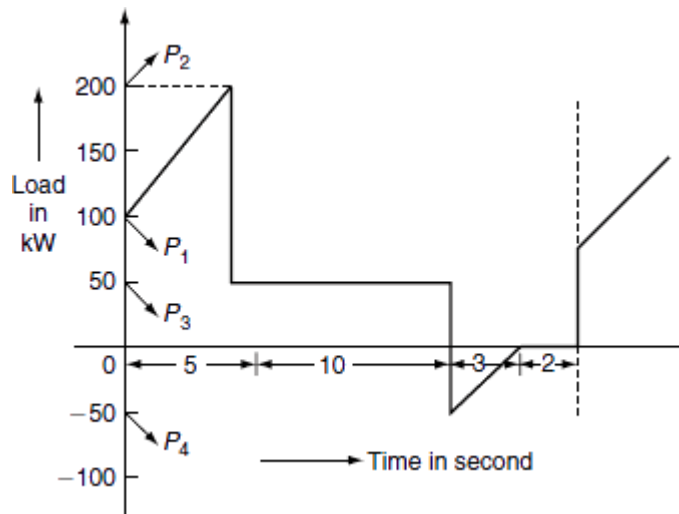

Fig. P.8.11 Load cycle

$$P_1 = 100 \text{ kW,}$$

$$t_1 = 5 \text{ s}$$

$$P_2 = 200 \text{ kW,}$$

$$t_2 = 10 \text{ s}$$

$$P_3 = 50 \text{ kW,}$$

$$t_3 = 3 \text{ s}$$

$$P_4 = -50 \text{ kW,}$$

$$t_4 = 2 \text{ s}$$

$$P_5 = 0 \text{ kW.}$$

$$\begin{aligned}
 (\text{Motor rating})^2 &= \frac{\int_0^5 \left(100 + \frac{(200-100)}{5}t\right)^2 dt + 50^2 \times 10 + \frac{1}{3}(-50)^2 \times 3 + 0^2 \times 2}{5 + 10 + 3 + 2 + 0} \\
 &= \frac{\int_0^5 (100 + 20t)dt + 25,000 + 2,500}{20} \\
 &= \frac{\int_0^5 (100)^2 + 400t^2 + 4,000t dt + 25,000 + 2,500}{20}
 \end{aligned}$$

$$\begin{aligned}
 (\text{Motor rating})^2 &= \frac{1/3(P_1^2 + P_1P_2 + P_2^2)t_1 + P_3^2t_2 + \frac{1}{3}P_4^2t_3}{T} \\
 &= \frac{1/3(100^2 + 100 \times 200 + 200^2) \times 5 + 50^2 \times 10 + 1/3 \times (-50)^2 \times 3}{20} \\
 &= 5,541.66.
 \end{aligned}$$

$$\therefore \text{Motor rating} = \sqrt{5541.66} = 74 \text{ kW.}$$

Alternative method:

$$\begin{aligned}
 &= \frac{\left[100^2t + \frac{400t^3}{3} + 4,000\frac{t^2}{2}\right]_0^5 + 27,500}{20} \\
 &= \frac{100^2 \times 5 + 400 \times \frac{5^3}{3} + 4,000 \times \frac{5^2}{2} + 27,500}{20} \\
 &= \frac{5 \times 10^4 + 16666.67 + 50,000 + 27500}{20} \\
 &= 7,208.3.
 \end{aligned}$$

$$\therefore \text{Motor rating} = \sqrt{7208.33} = 84.90 \text{ kW} \cong 85 \text{ kW.}$$

LOAD EQUALIZATION

The load fluctuations take place in many of the industrial drives such as rolling mills, planning machines presses, and reciprocating pumps, where the load on the motor varies widely within a span of few seconds. The sudden and peak load requires very large current from the supply results high voltage drop in the system or alternately would require very large size of cables. It is very essential to smooth out fluctuating load is known as '*load equalization*'. The load equalization involves the storage of energy during the off-peak period and gives out during the peak load period.

Load equalization process is commonly achieved by means of a flywheel. A flywheel is nothing but a big wheel that is mounted on the same shaft of motor, if the speed of the motor is not to be reversed or a heavy rotating body that acts as a reservoir for absorbing and redistributing stored energy is also known as flywheel.

Function of flywheel

To operate the flywheel efficiently, the driving motor should have drooping speed characteristics. The various models of flywheel are shown in [Fig. 8.42 \(a\) and \(b\)](#). During the lightload, the acceleration of the flywheel is increased and it stores the kinetic energy and at the time of peak load, the flywheel slows down and the stored kinetic energy is given out to the load; so that, the demand of the load from the motor or supply is reduced.

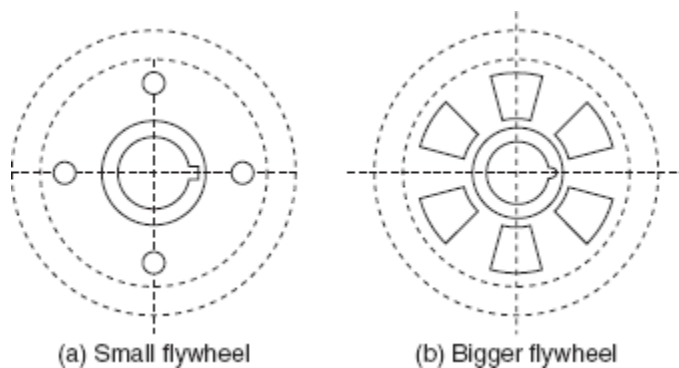

Fig. 8.42 Flywheel

It is necessary that the motor used for load equalization should have drooping characteristics. The flywheel is not used with motors having constant speed for example synchronous motor. The torque developed by the motor and the load torque required as well as the speed variations with time are shown in [Fig. 8.43](#).

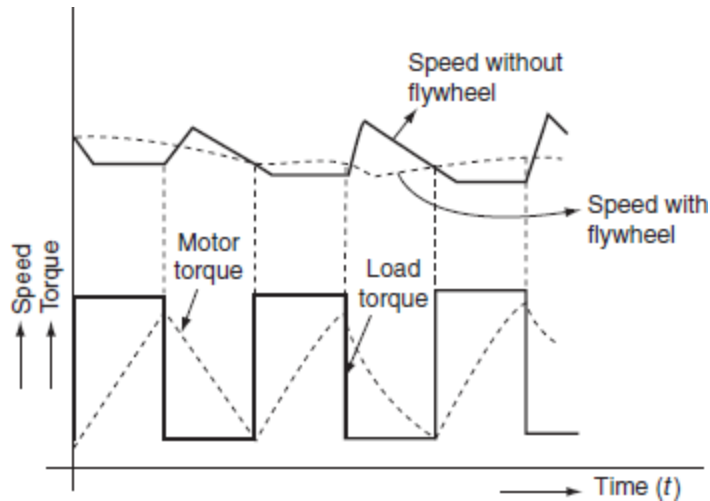

Fig. 8.43 Motor torque, load torque, and speed variations against time

Flywheel calculations

Let us consider a flywheel is attached to a variable speed motor to achieve load equalization.

Let T_L be the load torque (assumed constant during particular interval) in N-m. T_M is the motor torque in N-m, T_F is the flywheel torque in N-m, T_0 is the no-load torque in N-m, ω_0 is the motor speed on no-load in rad/sec, ω is the motor speed at any instant in rad/sec, and J is the moment of inertia of flywheel in kg-m^2 .

$$S = (\omega_0 - \omega) = \text{motor slip.}$$

Case (i): Let us consider that the load on the motor is increasing; during this period, the flywheel will decelerate and impart its stored kinetic energy to the load. The torque required to be supplied by the motor:

$$T_M = T_L - T_F. \quad (8.50)$$

The kinetic energy given by the flywheel when its speed reduced from ω_0 to ω is:

$$\begin{aligned}
\text{KE} &= \frac{1}{2}J(\omega_0^2 - \omega^2) \\
&= \frac{1}{2}J(\omega_0 + \omega)(\omega_0 - \omega) \\
&= J\left(\frac{\omega_0 + \omega}{2}\right)(\omega_0 - \omega). \tag{8.51}
\end{aligned}$$

$$\text{Let } \left(\frac{\omega_0 + \omega}{2}\right) = \omega \quad (\text{mean speed})$$

$$\omega_0 - \omega = S \quad (\text{Slip}).$$

Then, Equation (8.51) becomes:

$$\text{KE} = J\omega S. \tag{8.52}$$

The power given out by the flywheel = the rate of change of the energy given up by the flywheel.

$$\begin{aligned}
&= \frac{d}{dt}(J\omega S) \\
&= J\omega \frac{dS}{dt}. \tag{8.53}
\end{aligned}$$

$$\begin{aligned}
\text{The flywheel torque } (T_f) &= \frac{\text{power given out by flywheel}}{\omega} \\
&= \frac{J\omega \left(\frac{dS}{dt}\right)}{\omega} \\
&= J \frac{dS}{dt}. \tag{8.54}
\end{aligned}$$

By substituting Equation (8.54) in Equation (8.50), we get:

$$\begin{aligned}
 T_M &= T_L - T_F \\
 &= T_L - J \frac{dS}{dt}.
 \end{aligned}
 \tag{8.55}$$

If the slip, i.e., drop in speed limited to 10%, then the slip is proportional to the motor torque:

$$., S \propto T_M$$

$$S = KT_M.$$

$$\text{Then, } T_M = T_L - J \frac{d(KT_M)}{dt}$$

$$\begin{aligned}
 T_M &= T_L - JK \frac{dT_M}{dt} \\
 T_L - T_M &= JK \frac{dT_M}{dt} \\
 \frac{dT_M}{T_L - T_M} &= \frac{dt}{JK}.
 \end{aligned}
 \tag{8.56}$$

Integrating the Equation (8.56):

$$\begin{aligned}
 \int \frac{dT_M}{T_L - T_M} &= \int \frac{dt}{JK} \\
 -\log_e (T_L - T_M) &= \frac{t}{JK} + C,
 \end{aligned}
 \tag{8.57}$$

where C is proportionality constant.

At time $t = 0$, the motor torque will be equals to the no-load torque:

$$\text{i.e., at } t = 0, T_M = T_0. \quad (8.58)$$

The value of ' C ' can be determined by using the initial conditions. Substituting Equation (8.58) in Equation (8.57):

$$-\text{Log}_e(T_L - T_0) = \frac{0}{JK} + C \quad (8.59)$$

$$\therefore C = -\log_e(T_L - T_0).$$

Substituting ' C ' value in Equation (8.57):

$$\therefore -\text{Log}_e(T_L - T_M) = \frac{t}{JK} - \text{Log}_e(T_L - T_0)$$

$$-\text{Log}_e(T_L - T_0) + \log_e(T_L - T_M) = \frac{-t}{JK}$$

$$\text{Log}_e \left[\frac{T_L - T_M}{T_L - T_0} \right] = \frac{-t}{JK}.$$

Applying exponentials on both sides:

$$\left[\frac{T_L - T_M}{T_L - T_0} \right] = e^{-t/JK}$$

$$T_L - T_M = (T_L - T_0)e^{-t/JK}. \quad (8.60)$$

Case (ii): Now consider that the load is totally removed or decreasing, the motor starts accelerating and so the KE is stored by the flywheel.

Hence, the flywheel regains its normal speed; therefore, the slip decreases, i.e., $\frac{dS}{dt}$ is negative.

Now, motor torque will be:

$$T_M = T_0 + T_F \quad (8.61)$$

But,

$$T_F = -J \frac{dS}{dt} \quad (8.62)$$

Substitute Equation (8.62) in Equation (8.61):

$$\therefore T_M = T_0 - J \frac{dS}{dt} \quad (8.63)$$

We know that $S \propto T_M$:

$$\begin{aligned} S &= KT_M \\ \therefore T_M &= T_0 - JK \frac{dT_M}{dt} \\ -JK \frac{dT_M}{dt} &= T_M - T_0 \\ \frac{dT_M}{T_M - T_0} &= -\frac{dt}{JK} \end{aligned}$$

Integrating on both sides:

$$\int \frac{dT_M}{T_M - T_0} = - \int \frac{dt}{JK}$$
$$\text{Log}_e(T_M - T_0) = \frac{-t}{JK} + C_2, \quad (8.64)$$

where 'C₂' is integration constant.

The value of constant can be obtained by substituting the initial conditions in Equation (8.64).

At $t = 0$; $T_M = T_M^1$ (motor torque when load is decreased)

$$\therefore \text{Log}_e(T_M^1 - T_0) = \frac{0}{JK} + C_2$$

$$\therefore C_2 = \text{Log}_e(T_M^1 - T_0).$$

By substituting 'C₂' in Equation (8.64), we get:

$$\text{Log}_e(T_M - T_0) = \frac{-t}{JK} + \text{Log}_e(T_M^1 - T_0)$$

$$\text{Log}_e(T_M - T_0) - \text{Log}_e(T_M^1 - T_0) = \frac{-t}{JK}$$

$$\text{Log}_e \left(\frac{T_M - T_0}{T_M^1 - T_0} \right) = \frac{-t}{JK}.$$

Applying exponentials on both sides:

$$\frac{T_M - T_0}{T_M^1 - T_0} = e^{-t/JK}$$

$$\therefore T_M - T_0 = (T_M^1 - T_0)(e^{-t/JK})$$

$$\therefore T_M = T_0 + (T_M^1 - T_0)e^{-t/JK}. \quad (8.65)$$

Example 8.42: A 15-HP, three-phase, eight-pole, and 50-Hz induction motor provided with a flywheel has to supply a load torque of 600 N-m for 10 s followed by a no-load during which the flywheel regains the full speed. The full-load slip of the motor is 4% and the torque–speed curve may be assumed linear over the working range. Find the moment of inertia of the flywheel if the motor torque is not to exceed twice the full-load torque.

Solution:

Given data:

$$P_0 = 15 \text{ HP}$$

$$= 15 \times 735.5 = 11.03 \text{ kW.}$$

$$\text{No. of poles } P = 8$$

$$f = 50 \text{ Hz}$$

$$S_f = 0.04$$

$$t = 10 \text{ sec}$$

$$T_L = 600 \text{ N-m}$$

$$T_M = 2 \cdot T_{FL}$$

$$T_0 = 0.$$

$$\begin{aligned} \text{Now, synchronous speed } N_s &= \frac{120f}{P} \\ &= \frac{120 \times 50}{8} = 750 \text{ rpm.} \end{aligned}$$

$$\text{Full-load torque } T_{FL} = \frac{60 \times P_0}{2\pi N_{FL}}$$

$$\begin{aligned} N_{FL} &= N_s (1 - S_f) = 750 (1 - 0.04) \\ &= 720 \text{ rpm.} \end{aligned}$$

$$T_{FL} = \frac{60 \times 11.03 \times 10^3}{2\pi \times 720} = 146.39 \text{ N-m.}$$

$$\therefore T_M = 2T_{FL} = 2 \times 146.39 = 292.78 \text{ N-m.}$$

$$\begin{aligned} \text{Slip speed} &= S_f \times N_s = 0.04 \times 750 \\ &= 30 \text{ rpm} \\ &= \frac{30 \times 2\pi}{60} = 3.14 \text{ rad/s.} \end{aligned}$$

$$\text{And, } K = \frac{S}{T_{FL}} = \frac{3.14}{146.39} = 0.0214$$

$$\therefore T_M = T_L - (T_L - T_0)e^{-t/JK}$$

$$-t/JK = \ln\left(\frac{T_L - T_M}{T_L - T_0}\right)$$

$$-t/JK = \ln\left[\frac{600 - 292.78}{600}\right] = 0.669$$

$$J = \frac{t}{0.669 \times K} = \frac{10}{0.669 \times 0.0214} = 698.49 \text{ kg-m}^2.$$

$$T_M = T_L - (T_L - T_0)e^{-t/KJ}$$

$$e^{-t/KJ} = \frac{T_L - T_M}{T_L - T_0}$$

$$e^{-t/KJ} = \frac{800 - 600}{800 - 0} = 0.25$$

$$-t/KJ = \ln(0.25) = \frac{5}{1.386 \times 0.01134}$$

$$J = 318.12 \text{ kg-m}^2.$$

UNIT 2

Electric Heating

INTRODUCTION

Heat plays a major role in everyday life. All heating requirements in domestic purposes such as cooking, room heater, immersion water heaters, and electric toasters and also in industrial purposes such as welding, melting of metals, tempering, hardening, and drying can be met easily by electric heating, over the other forms of conventional heating. Heat and electricity are interchangeable. Heat also can be produced by passing the current through material to be heated. This is called electric heating; there are various methods of heating a material but electric heating is considered far superior compared to the heat produced by coal, oil, and natural gas.

ADVANTAGES OF ELECTRIC HEATING

The various advantages of electric heating over other the types of heating are:

(i) Economical

Electric heating equipment is cheaper; they do not require much skilled persons; therefore, maintenance cost is less.

(ii) Cleanliness

Since dust and ash are completely eliminated in the electric heating, it keeps surroundings cleanly.

(iii) Pollution free

As there are no flue gases in the electric heating, atmosphere around is pollution free; no need of providing space for their exit.

(iv) Ease of control

In this heating, temperature can be controlled and regulated accurately either manually or automatically.

(v) Uniform heating

With electric heating, the substance can be heated uniformly, throughout whether it may be conducting or non-conducting material.

(vi) High efficiency

In non-electric heating, only 40–60% of heat is utilized but in electric heating 75–100% of heat can be successfully utilized. So, overall efficiency of electric heating is very high.

(vii) Automatic protection

Protection against over current and over heating can be provided by using fast control devices.

(viii) Heating of non-conducting materials

The heat developed in the non-conducting materials such as wood and porcelain is possible only through the electric heating.

(ix) Better working conditions

No irritating noise is produced with electric heating and also radiating losses are low.

(x) Less floor area

Due to the compactness of electric furnace, floor area required is less.

(xi) High temperature

High temperature can be obtained by the electric heating except the ability of the material to withstand the heat.

(xii) Safety

The electric heating is quite safe.

MODES OF TRANSFER OF HEAT

The transmission of the heat energy from one body to another because of the temperature gradient takes place by any of the following methods:

1. conduction,
2. convection, or
3. radiation.

Conduction

In this mode, the heat transfers from one part of substance to another part without the movement in the molecules of substance. The rate of the conduction of heat along the substance depends upon the temperature gradient.

The amount of heat passed through a cubic body with two parallel faces with thickness ' t ' meters, having the cross-sectional area of ' A ' square meters and the temperature of its two faces $T_1^\circ\text{C}$ and $T_2^\circ\text{C}$, during ' T ' hours is given by:

$$Q = \frac{k A}{t} (T_1 - T_2) T \text{ MJ},$$

where k is the coefficient of the thermal conductivity for the material and it is measured in $\text{MJ/m}^3/\text{C/hr}$.

Ex: Refractory heating, the heating of insulating materials, etc.

Convection

In this mode, the heat transfer takes place from one part to another part of substance or fluid due to the actual motion of the molecules. The rate of conduction of heat depends mainly on the difference in the fluid density at different temperatures.

Ex: Immersion water heater.

The amount of heat absorbed by the water from heater through convection depends mainly upon the temperature of heating element and also depends partly on the position of the heater.

Heat dissipation is given by the following expression.

$$H = a (T_1 - T_2)^b \text{ W/m}^2,$$

where ' a ' and ' b ' are the constants whose values are depend upon the heating surface and T_1 and T_2 are the temperatures of heating element and fluid in $^\circ\text{C}$, respectively.

Radiation

In this mode, the heat transfers from source to the substance to be heated without heating the medium in between. It is dependent on surface.

Ex: Solar heaters.

The rate of heat dissipation through radiation is given by Stefan's Law.

$$\text{Heat dissipation, } H = 5.72 \times 10^4 k e \left[\left(\frac{T_1}{1,000} \right)^4 - \left(\frac{T_2}{1,000} \right)^4 \right] \text{ W/m}^2, \quad (4.1)$$

where T_1 is the temperature of the source in kelvin, T_2 is the temperature of the substance to be heated in kelvin, and k is the radiant efficiency:

= 1, for single element

= 0.5–0.8, for several elements

e = emissivity = 1, for black body

= 0.9, for resistance heating element.

From Equation (4.1), the radiant heat is proportional to the difference of fourth power of the temperature, so it is very efficient heating at high temperature.

ESSENTIAL REQUIREMENTS OF GOOD HEATING ELEMENT

The materials used for heating element should have the following properties:

- **High-specific resistance**
Material should have high-specific resistance so that small length of wire may be required to provide given amount of heat.
- **High-melting point**
It should have high-melting point so that it can withstand for high temperature, a small increase in temperature will not destroy the element.
- **Low temperature coefficient of resistance**
From Equation (4.1), the radiant heat is proportional to fourth powers of the temperatures, it is very efficient heating at high temperature.
For accurate temperature control, the variation of resistance with the operating temperature should be very low. This can be obtained only if the material has low temperature coefficient of resistance
- **Free from oxidation**

The element material should not be oxidized when it is subjected to high temperatures; otherwise the formation of oxidized layers will shorten its life.

- **High-mechanical strength**
The material should have high-mechanical strength and should withstand for mechanical vibrations.
- **Non-corrosive**
The element should not corrode when exposed to atmosphere or any other chemical fumes.
- **Economical**

The cost of material should not be so high.

MATERIAL FOR HEATING ELEMENTS

The selection of a material for heating element is depending upon the service conditions such as maximum operating temperature and the amount of charge to be heated, but no single element will not satisfy all the requirements of the heating elements. The materials normally used as heating elements are either alloys of nickel–chromium, nickel–chromium–iron, nickel–chromium–aluminum, or nickel–copper.

Nickel–chromium–iron alloy is cheaper when compared to simple nickel–chromium alloy. The use of iron in the alloy reduces the cost of final product but, reduces the life of the alloy, as it gets oxidized soon. We have different types of alloys for heating elements. Table 4.1 gives the relevant properties of some of the commercial heating elements.

Table : Properties of some heating elements

S. No.	Type of alloy	Composition	Commercial name	Max. operating temperature	Resistivity at 20°C	Specific gravity
1	Nickel chromium (Ni–Cr)	80% Ni 20% Cr	Nichrome	1,150°C	1.03 $\mu\Omega\text{-m}$	8.35
2	Nickel chromium iron (Ni–Cr–Fe)	60% Ni 16% Cr 24% Fe	—	950°C	1.06 $\mu\Omega\text{-m}$	8.27
3	Nickel Copper (Ni–Cu)	45% Ni 55% Cu	Eureka or constantan	400°C	0.49 $\mu\Omega\text{-m}$	8.88
4	Iron chromium aluminum (Fe–Cr–Al)	70% Fe 25% Cr 5% Al	Kanthal	1,200°C	1.4 $\mu\Omega\text{-m}$	7.20

The properties of some commercial heating element materials commonly employed for low and medium temperatures up to 1,200°C are Ni–Cr and an alloy of Ni–Cr–Fe composition of these alloys are given in Table 4.1. For operating temperatures above 1,200°C, the heating elements are made up of silicon carbide, molybdenum, tungsten, and graphite. (Ni–Cu alloy is frequently used for heating elements operating at low temperatures. Its most important property is that it has virtually zero resistance and temperature coefficient.)

CAUSES OF FAILURE OF HEATING ELEMENTS

Heating element may fail due to any one of the following reasons.

1. Formation of hot spots.
2. Oxidation of the element and intermittency of operation.
3. Embrittlement caused by grain growth.
4. Contamination and corrosion.

Formation of hotspots

Hotspots are the points on the heating element generally at a higher temperature than the main body. The main reasons of the formation of hotspot in the heating element are the high rate of the local oxidation causing reduction in the area of cross-section of the element leading to the increase in the resistance at that spot. It gives rise to the damage of heating element due to the generation of more heat at spot. Another reason is the shielding of element by supports, etc., which reduces the local heat loss by radiation and hence the temperature of the shielded portion of the element will increase. So that the minimum number of supports should be used without producing the distortion of the element. The sagging and warping of the material arise due to the insufficient support for the element (or) selection of wrong fuse material may lead to the uneven spacing of sections thereby developing the hotspots on the element.

Oxidation and intermittency of operation

A continuous oxide layer is formed on the surface of the element at very high temperatures such layer is so strong that it prevents further oxidation of the inner metal of the element. If the element is used quite often, the oxide layer is subjected to thermal stresses; thus, the layer cracks and flakes off, thereby exposing fresh metal to oxidation. Thus, the local oxidation of the metal increases producing the hotspots.

Embrittlement causing grain growth

In general, most of the alloys containing iron tend to form large brittle grains at high temperatures. When cold, the elements are very brittle and liable to rupture easily on the slightest handling and jerks.

contamination and corrosion

The heating elements may be subjected to dry corrosion produced by their contamination with the gases of the controlled atmosphere prevailing in annealing furnaces.

DESIGN OF HEATING ELEMENTS

By knowing the voltage and electrical energy input, the design of the heating element for an electric furnace is required to determine the size and length of the heating element. The wire employed may be circular or rectangular like a ribbon. The ribbon-type heating element permits the use of higher wattage per unit area compared to the circular-type element.

Circular-type heating element

Initially when the heating element is connected to the supply, the temperature goes on increasing and finally reaches high temperature.

Let V be the supply voltage of the system and R be the resistance of the element, then electric power input, $P = \frac{V^2}{R}$ W.

If ρ is the resistivity of the element, l is the length, ' a ' is the area, and d is the diameter of the element, then:

$$R = \rho \frac{l}{a} = \frac{\rho l}{\frac{\pi d^2}{4}}$$

Therefore, power input,

$$P = \frac{V^2 \pi d^2}{4 \rho l} \quad (4.2)$$

By rearranging the above equation, we get:

$$\frac{l}{d^2} = \frac{\pi V^2}{4P \rho}, \quad (4.3)$$

where P is the electrical power input per phase (watt), V is the operating voltage per phase (volts), R is the resistance of the element (Ω), l is the length of the element (m), a is the area of cross-section (m^2), d is the diameter of the element (m), and ρ is the specific resistance ($\Omega\text{-m}$)

According to Stefan's law, heat dissipated per unit area is

$$H = 5.72 \times 10^4 k e \left[\left(\frac{T_1}{1,000} \right)^4 - \left(\frac{T_2}{1,000} \right)^4 \right] \text{W/m}^2, \quad (4.4)$$

where T_1 is the absolute temperature of the element (K), T_2 is the absolute temperature of the charge (K), e is the emissivity, and k is the radiant efficiency.

The surface area of the circular heating element:

$$S = \pi dl.$$

\therefore Total heat dissipated = surface area $\times H$

$$= H\pi dl.$$

Under thermal equilibrium,

Power input = heat dissipated

$$P = H \times \pi dl.$$

Substituting P from Equation (4.2) in above equation:

$$\frac{V^2 \left(\frac{\pi d^2}{4} \right)}{\rho l} = H \times \pi dl$$

$$\therefore \frac{d}{l^2} = \frac{4 \rho H}{V^2}. \quad (4.5)$$

By solving Equations (4.3) and (4.4), the length and diameter of the wire can be determined.

Ribbon-type element

Let 'w' be the width and 't' be the thickness of the ribbon-type heating element.

$$\text{Electrical power input } P = \frac{V^2}{R}. \quad (4.6)$$

We know that, $R = \frac{\rho l}{a} = \frac{\rho l}{w \times t}$ (for ribbon or rectangular element, $a = w \times t$)

$$\therefore P = \frac{V^2}{\left(\frac{\rho l}{w \times t} \right)}$$

$$\therefore \frac{l}{w} = \frac{V^2 t}{P \rho}. \quad (4.7)$$

The surface area of the rectangular element (S) = $2 l \times w$.

\therefore Total heat dissipated = $H \times S$

$$= H \times 2 lw.$$

\therefore Under the thermal equilibrium,

Electrical power input = heat dissipated

$$P = H \times 2 lw$$

$$lw = \frac{P}{2H}. \quad (4.8)$$

By solving Equations (4.7) and (4.8), the length and width of the heating element can be determined.

Example 4.1: A 4.5-kW, 200-V, and 1- ϕ resistance oven is to have nichrome wire heating elements. If the wire temperature is to be 1,000°C and that of the charge 500°C. Estimate the diameter and length of the wire. The resistivity of the nichrome alloy is 42.5 $\mu\Omega$ -m. Assume the radiating efficiency and the emissivity of the element as 1.0 and 0.9, respectively.

Solution:

Given data

Power input (P) = 4.5 kW

Supply voltage (V) = 200 V

Temperature of the source (T_1) = 1,000 + 273

$$= 1,273 \text{ K.}$$

Temperature of the charge $T_2 = 500 + 273$

$$= 773 \text{ K.}$$

According to the Stefan's law,

$$\begin{aligned} \text{The amount of heat dissipation } (H) &= 5.72 \times 10^4 \times k e \left[\left(\frac{T_1}{1,000} \right)^4 - \left(\frac{T_2}{1,000} \right)^4 \right] \text{ W/m}^2 \\ H &= 5.72 \times 10^4 \times 0.1 \times 0.9 \left[\left(\frac{1,273}{1,000} \right)^4 - \left(\frac{773}{1,000} \right)^4 \right] \\ &= 11.68 \times 10^3 \text{ W/m}^2. \end{aligned}$$

$$\begin{aligned}
\text{Power, } P &= \frac{V^2}{R} \\
&= \frac{V^2}{\frac{\rho l}{A}} \quad \left(R = \frac{\rho l}{A} \right) \\
&= \frac{V^2 A}{\rho l} \\
&= \frac{V^2 \pi d^2}{4 \rho l} \quad \left[\because \text{The area of circular type element} = \frac{\pi}{4} d^2 \right] \\
\frac{d^2}{l} &= \frac{4 P \rho}{V^2 \pi} \\
&= \frac{4 \times 42.5 \times 10^{-6} \times 4.5 \times 10^3}{(200)^2 \times 3.14} \\
&= 6.09 \times 10^{-9}. \tag{1}
\end{aligned}$$

The heat dissipation is given by:

$$\begin{aligned}
P &= H \times S \quad (S = \text{circular full-face area}) \\
&= H \times \pi dl \\
dl &= \frac{P}{H \pi} = \frac{4.5 \times 10^3}{3.14 \times 11.68 \times 10^3} \\
l &= 0.1226. \tag{2}
\end{aligned}$$

By solving Equations (1) and (2):

$$d^3 = 0.7466$$

$$d = 0.907 \text{ mm.}$$

Substitute the value of 'd' in Equation (2):

$$l = 135.14 \text{ m.}$$

Example 4.2: A 20-kW, 230-V, and single-phase resistance oven employs nickel—chrome strip 25-mm thick is used, for its heating elements. If the wire temperature is not to exceed 1,200°C and the temperature of the charge is to be 700°C. Calculate the width and length of the wire. Assume the radiating efficiency as 0.6 and emissivity as 0.9. Determine also the temperature of the wire when the charge is cold.

Solution:

Power supplied, $P = 20 \times 10^3 \text{ W}$.

Let 'w' be the width in meters, t be the thickness in meters, and ' l ' be the length also in meters. Then:

$$\begin{aligned}
 P &= \frac{V^2}{R} \\
 &= \frac{V^2}{\frac{\rho l}{A}} \\
 &= \frac{V^2 \times wt}{\rho l} \quad (\text{since } A = w \times t) \\
 \frac{w}{l} &= \frac{P \rho}{V^2 t} \\
 &= \frac{20 \times 10^3 \times 1.016 \times 10^{-6}}{(230)^2 \times 0.25 \times 10^{-3}} \\
 &= 1.536 \times 10^{-3}. \tag{1}
 \end{aligned}$$

According to the Stefan's law of heat radiation:

$$H = 5.72 \times 10^4 \times ke \left[\left(\frac{T_1}{1,000} \right)^4 - \left(\frac{T_2}{1,000} \right)^4 \right] \text{W/m}^2$$

$$H = 5.72 \times 10^4 \times 0.6 \times 0.9 \left[\left(\frac{1,200 + 273}{1,000} \right)^4 - \left(\frac{700 + 273}{1,000} \right)^4 \right]$$

$$(\because T_1 = 1,200 + 273 = 1,473 \text{ K}, \quad T_2 = 700 + 273 = 973 \text{ K})$$

$$H = 117.714 \text{ kW/m}^2.$$

The total amount of the heat dissipation \times the surface area of strip = power supplied

$$P = H \times S$$

$$= H \times 2 lw \quad (S = \text{surface area of strip} = 2lw)$$

$$lw = \frac{P}{2H}$$

$$= \frac{20 \times 10^3}{2 \times 117.714 \times 10^3}$$

$$= 0.0849.$$

(2)

From Equations (1) and (2):

$$\frac{w}{l} \times lw = 1.536 \times 10^{-3} \times 0.0849$$

$$w^2 = 1.304 \times 10^{-4}$$

$$w = 11.42 \text{ mm.}$$

Substitute the value of 'w' in Equation (2) then:

$$l = 7.435 \text{ m.}$$

When the charge is cold, it would be at normal temperature, say 25°C.

$$117.714 \times 10^3 = 5.72 \times 10^4 \times 0.6 \times 0.9 \left[\left(\frac{T_1}{1,000} \right)^4 - \left(\frac{273+25}{1,000} \right)^4 \right]$$

$$\left(\frac{T_1}{1,000} \right)^4 - 0.00788 = 3.8109$$

$$\left(\frac{T_1}{1,000} \right)^4 = 3.818$$

$$T_1 = 1,397.9169 \text{ K absolute}$$

$$\text{Or, } T_1 = 1,124.9^\circ\text{C.}$$

Example 4.3 Determine the diameter and length of the wire, if a 17-kW, 220-V, and 1- ϕ resistance oven employs nickel-chrome wire for its heating elements. The temperature is not exceeding to 1,100°C and the temperature of the charge is to be 500°C. Assume the radiating efficiency as 0.5 and the emissivity as 0.9, respectively.

Solution:

For a circular element:

$$P = \frac{V^2}{R}$$

$$= \frac{V^2}{\frac{\rho l}{A}}$$

$$= \frac{V^2 A}{\rho l}$$

$$= \frac{V^2 \pi d^2}{\rho l 4} \quad \left[\because \text{The area of circular element } A = \frac{\pi d^2}{4} \right]$$

$$\frac{d^2}{l} = \frac{4 P \rho}{V^2 \pi}$$

$$= \frac{4 \times 17 \times 10^3 \times 1.016 \times 10^{-6}}{(220)^2 \times 3.14}$$

$$= 4.545 \times 10^{-7}.$$

(1)

According to Stefan's law of heat dissipation:

$$H = 5.72 \times 10^4 \text{ ke} \left[\left(\frac{T_1}{1,000} \right)^4 - \left(\frac{T_2}{1,000} \right)^4 \right] \text{ W/m}^2$$

$$\begin{aligned} H &= 5.72 \times 10^4 \times 0.5 \times 0.9 \left[\left(\frac{1,100 + 273}{1,000} \right)^4 - \left(\frac{500 + 273}{1,000} \right)^4 \right] \\ &= 82.28 \text{ kW/m}^2. \end{aligned}$$

At steady temperature, crucial power input = heat output:

$$P = H \times \pi dl$$

$$\begin{aligned} dl &= \frac{P}{H \times \pi} \\ &= \frac{7 \times 10^3}{3.14 \times 62.28 \times 10^3} \\ &= 0.0658. \end{aligned}$$

Solving Equations (1) and (2), we get:

$$\begin{aligned} \frac{d^2}{l} \times dl &= 4.545 \times 10^{-7} \times 0.0658 \\ d^3 &= 2.99 \times 10^{-8} \\ d &= 3.1 \text{ mm}. \end{aligned}$$

Substitute the value of 'd' in Equation (2) gives:

$$l = 21.198 \text{ m}.$$

METHODS OF ELECTRIC HEATING

Heat can be generated by passing the current through a resistance or induced currents. The initiation of an arc between two electrodes also develops heat. The bombardment by some heat energy particles such as α , γ , β , and x-rays or accelerating ion can produce heat on a surface.

Electric heating can be broadly classified as follows.

(i) Direct resistance heating

In this method, the electric current is made to pass through the charge (or) substance to be heated. This principle of heating is employed in electrode boiler.

(ii) Indirect resistance heating

In this method, the electric current is made to pass through a wire or high-resistance heating element, the heat so developed is transferred to charge from the heating element by convection or radiation. This method of heating is employed in immersion water heaters.

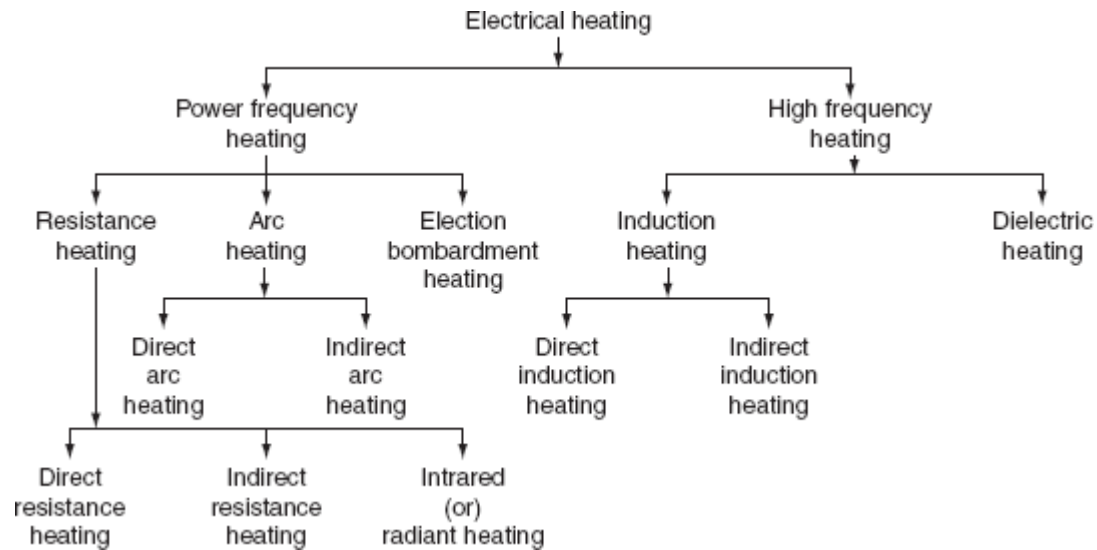

Fig. Classification of electrical heating

Infrared (or) radiant heating

In this method of heating, the heat energy is transferred from source (incandescent lamp) and focused upon the body to be heated up in the form of electromagnetic radiations. Normally, this method is used for drying clothes in the textile industry and to dry the wet paints on an object.

Direct arc heating

In this method, by striking the arc between the charge and the electrode or electrodes, the heat so developed is directly conducted and taken by the charge. The furnace operating on this principle is known as direct arc furnaces. The main application of this type of heating is production of steel.

Indirect arc heating

In this method, arc is established between the two electrodes, the heat so developed is transferred to the charge (or) substance by radiation. The furnaces operating on this principle are known as indirect arc furnaces. This method is generally used in the melting of non-ferrous metals.

Direct induction heating

In this method of heating, the currents are induced by electromagnetic action in the charge to be heated. These induced currents are used to melt the charge in induction furnace.

Indirect induction heating

In this method, eddy currents are induced in the heating element by electromagnetic action. Thus, the developed heat in the heating element is transferred to the body (or) charge to be heated by radiation (or) convection. This principle of heating is employed in induction furnaces used for the heat treatment of metals.

Dielectric heating

In this method of electric heating, the heat developed in a non-metallic material due to inter-atomic friction, known as dielectric loss. This principle of heating usually employed for preheating of plastic performs, baking foundry cores, etc.

RESISTANCE HEATING

When the electric current is made to pass through a high-resistive body (or) substance, a power loss takes place in it, which results in the form of heat energy, i.e., resistance heating is passed upon the I^2R effect. This method of heating has wide applications such as drying, baking of potteries, commercial and domestic cooking, and the heat treatment of metals such as annealing and hardening. In oven where wire resistances are employed for heating, temperature up to about 1,000°C can be obtained.

The resistance heating is further classified as:

1. direct resistance heating,
2. indirect resistance heating, and

3. infrared (or) radiant heating.

Direct resistance heating

In this method, electrodes are immersed in a material or charge to be heated. The charge may be in the form of powder, pieces, or liquid. The electrodes are connected to AC or DC supply as shown in Fig. 4.1(a). In case of DC or 1- ϕ AC, two electrodes are immersed and three electrodes are immersed in the charge and connected to supply in case of availability of 3- ϕ supply. When metal pieces are to be heated, the powder of lightly resistive is sprinkled over the surface of the charge (or) pieces to avoid direct short circuit. The current flows through the charge and heat is produced in the charge itself. So, this method has high efficiency. As the current in this case is not variable, so that automatic temperature control is not possible. This method of heating is employed in salt bath furnace and electrode boiler for heating water.

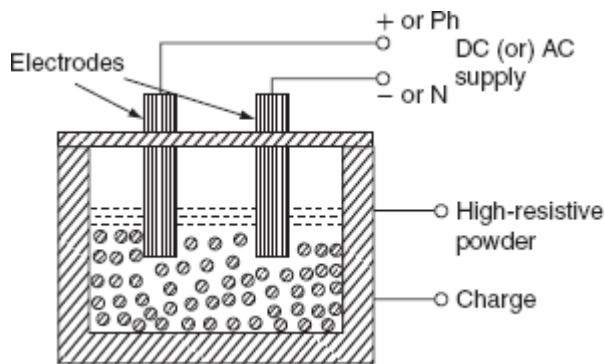

Fig. (a) Direct resistance heating

(i) Salt bath furnace

This type of furnace consists of a bath and containing some salt such as molten sodium chloride and two electrodes immersed in it.

Such salt have a fusing point of about 1,000–1,500°C depending upon the type of salt used. When the current is passed between the electrodes immersed in the salt, heat is developed and the temperature of the salt bath may be increased. Such an arrangement is known as a salt bath furnace.

In this bath, the material or job to be heated is dipped. The electrodes should be carefully immersed in the bath in such a way that the current flows through the salt and not through the job being heated. As DC will cause electrolysis so, low-voltage AC up to 20 V and current up to 3,000 A is adopted depending upon the type of furnaces.

The resistance of the salt decreases with increase in the temperature of the salt, therefore, in order to maintain the constant power input, the voltage can be controlled by providing a tap changing transformer. The control of power input is also affected by varying the depth of immersion and the distance between the electrodes.

(ii) *Electrode boiler*

It is used to heat the water by immersing three electrodes in a tank as shown in Fig. 4.2. This is based on the principle that when the electric current passed through the water produces heat due to the resistance offered by it. For DC supply, it results in a lot of evolution of H_2 at negative electrode and O_2 at positive electrode. Whereas AC supply hardly results in any evolution of gas, but heats the water. Electrode boiler tank is earthed solidly and connected to the ground. A circuit breaker is usually incorporated to make and break all poles simultaneously and an over current protective device is provided in each conductor feeding an electrode.

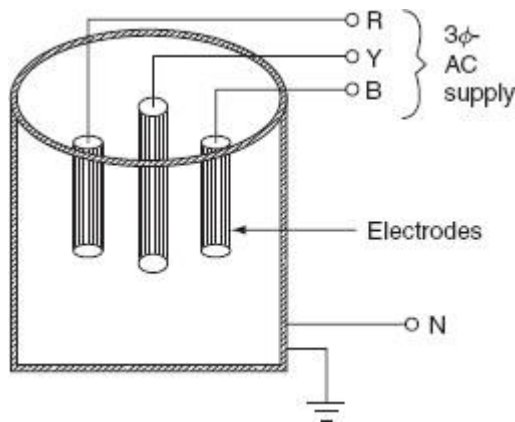

Fig. 4.2 Electrode boiler

Indirect resistance heating

In the indirect resistance heating method, high current is passed through the heating element. In case of industrial heating, some times the heating element is placed in a cylinder which is surrounded by the charge placed in a jacket is known as heating chamber is shown in Fig. 4.3. The heat is proportional to power loss produced in the heating element is delivered to the charge by one or more of the modes of the transfer of heat viz. conduction, convection, and radiation. This arrangement provides uniform temperature and automatic temperature control. Generally, this method of heating is used in immersion water heaters, room heaters, and the resistance ovens used in domestic and commercial cooling and salt bath furnace.

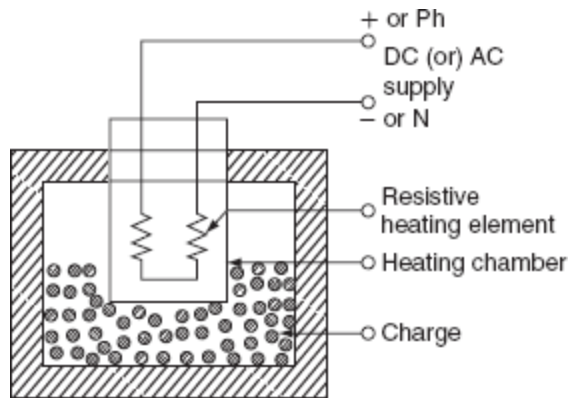

Fig. 4.3 Indirect resistance heating

Resistance ovens

According to the operating temperatures, the resistance furnaces may be classified into various types. Low-temperature heating chamber with the provision for ventilation is called as oven. For drying varnish coating, the hardening of synthetic materials, and commercial and domestic heating, etc., the resistance ovens are employed. The operating temperature of medium temperature furnaces is between 300°C and 1,050°C. These are employed for the melting of non-ferrous metals, stove (annealing), etc. Furnaces operating at temperature between 1,050°C and 1,350°C are known as high-temperature furnaces. These furnaces are employed for hardening applications. A simple resistance oven is shown in [Fig. 4.4](#).

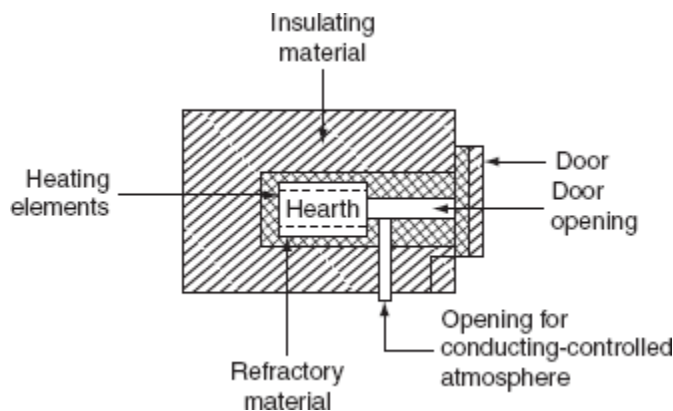

Fig. 4.4 Resistance oven

Resistance oven consists of a heating chamber in which heating elements are placed as shown in the [Fig. 4.4](#). The inner surface of the heating chamber is made to suit the character of the

charge and the type of furnace or oven. The type of insulation used for heating chamber is determined by the maximum temperature of the heating chamber.

Efficiency and losses of resistance ovens

The heat produced in the heating elements, not only raises the temperature of the charge to desired value, but also used to overcome the losses occurring due to:

1. Heat used in raising the temperature of oven (or) furnace.
2. Heat used in raising the temperature of containers (or) carriers,
3. Heat conducted through the walls.
4. Heat loss due to the opening of oven door.

1. The heat required to raise the temperature of oven to desired value can be calculated by knowing the mass of refractory material (M), its specific heat (S), and raise of temperature (ΔT) and is given by:

$$H_{\text{oven}} = MS\Delta T J.$$

In case the oven is continuously used, this loss becomes negligible.

2. Heat used in rising the temperature of containers (or) carriers can be calculated exactly the same way as for oven (or) furnaces.

3. Heat loss conducted through the walls of the container can be calculated by knowing the area of the container (A) in square meters, the thickness of the walls (t) in meters, the inside and out side temperatures of the container T_1 and T_2 in $^{\circ}\text{C}$, respectively, and the thermal conductivity of the container walls ' k ' in $\text{m}^3/\text{C}/\text{hr}$ and is given by: Heat loss by conduction $= \frac{k A (T_1 - T_2)}{t} \text{ W}.$

Actually, there is no specific formula for the determination of loss occurring due to the opening of door for the periodic inspection of the charge so that this loss may be approximately taken as $0.58\text{--}1.15 \text{ MJ/m}^2$ of the door area, if the door is opened for a period of $20\text{--}30$ sec.

The *efficiency of the oven* is defined as the ratio of the heat required to raise the temperature of the charge to the desired value to the heat required to raise the charge and losses.

The efficiency of the oven:

$$= \frac{\text{the heat required to raise the temperature of the charge}}{\text{the heat required to raise the temperature of the charge} + \text{total losses}}$$

The efficiency of the resistance oven lies in between 60% and 80%.

Infrared or radiant heating

In this method of heating, the heat transfer takes place from the source to the body to be heated through radiation, for low and medium temperature applications. Whereas in resistance ovens, the heat transfers to the charge partly by convection and partly by radiation. In the radiant heating, the heating element consists of tungsten filament lamps together with reflector and to direct all the heat on the charge. Tungsten filament lamps are operating at 2,300°C instead of 3,000°C to give greater portion of infrared radiation and a longer life. The radiant heating is mainly used for drying enamel or painted surfaces. The high concentration of the radiant energy enables the heat to penetrate the coating of paint or enamel to a depth sufficient to dry it out without wasting energy in the body of the workpiece.

The main advantage of the radiant heating is that the heat absorption remains approximately constant whatever the charge temperature, whereas with the ordinary oven the heat absorption falls off very considerably as the temperature of the charge raises. The lamp ratings used are usually between 250 and 1,000 W and are operating at voltage of 115 V in order to ensure a robust filament.

TEMPERATURE CONTROL OF RESISTANCE HEATING

To control the temperature of a resistance heating at certain selected points in a furnace or oven, as per certain limits, such control may be required in order to hold the temperature constant or to vary it in accordance with a pre-determined cycle and it can be carried out by hand or automatically.

In resistance furnaces, the heat developed depends upon $I^2 R t$ (or) $\frac{V^2}{R} t$. Therefore, the temperature of the furnaces can be controlled either by:

1. Changing the resistance of elements.
2. Changing the applied voltage to the elements (or) current passing through the elements.
3. Changing the ratio of the on-and-off times of the supply.

Voltage across the furnace can be controlled by changing the transformer tapings. Auto transformer or induction regulator can also be used for variable voltage supply. In addition to the above, voltage can be controlled by using a series resistance so that some voltage dropped across this series resistor. But this method is not economical as the power is continuously wasted in controlling the resistance. Hence, this method is limited to small furnaces. An on-off switch can be employed to control the temperature. The time for which the oven is connected to the supply and the time for which it is disconnected from supply will determine the temperature.

Temperature can be controlled by providing various combinations of groups of resistances used in the furnace and is given as follows:

(i) Variable number of elements

If 'R' be the resistance of one element and 'n' be the number of elements are connected in parallel, so that the equivalent resistance is R/n .

Heat developed in the furnace is:

$$H = \frac{V^2}{(R/n)} = \frac{V^2}{R} \times n$$

i.e., if the number of elements connected in parallel increases, the heat developed in the furnace also increased. This method does not provide uniform heating unless elements not in use are well distributed.

(ii) Series parallel (or) star delta arrangement of elements

If the available supply is single phase, the heating elements can be connected in series for the low temperatures and connected in parallel for the high temperature by means of a series—parallel switch.

In case, if the available supply is three phase, the heating elements can be connected in star for the low temperature and in delta for the high temperatures by using star—delta switch.

Example 4.5: Six resistances, each of 60 ohms, are used in a resistance; how much power is drawn for the following connections.

1. Supply is 400 V, AC, and single phase and the connections are:
 1. Three groups in parallel, each of two resistance units in series.
 2. Six groups are in parallel, each of one resistance unit.
2. With the same three-phase supply, they are connected in delta fashion.
0. Two resistance units in parallel in each branch.
 1. Two resistance units in series in each branch.
3. Supply is 400 V and three-phase while the connection is a star combination of:
 0. Two resistance elements in series in each phase.
 1. Two resistance elements in parallel in each phase.

4. If the supply is a 25% tapping with an auto transformer, calculate the output of the oven.

Solution:

1.

1. The power consumption of the two resistances in series is:

$$P = \frac{V^2}{R} = \frac{(400)^2}{2 \times 60} \\ = 1,333.33 \text{ W.}$$

The power consumed by the three units in parallel is $P = 3 \times 1,333.33 = 4,000 \text{ W}$.

2. The power consumed by each resistor is:

$$P = \frac{V^2}{R} = \frac{(400)^2}{60} \\ = 2,666.67 \text{ W.}$$

The power consumed by the six resistors in parallel is:

$$P = 6 \times 2,666.67 \\ = 16,000 \text{ W.}$$

2. Since in delta fashion, line voltage = phase voltage = 400 V:

0. The power consumed by the each branch:

$$P = \frac{V^2}{R} = \frac{(400)^2}{30} \\ = 5,333.34 \text{ W.}$$

The power consumed by the three units is:

$$P = 3 \times 5,333.34 \\ = 16,000 \text{ W.}$$

1. The power consumed by the each unit, when they are commuted in series is:

$$P = \frac{V^2}{R} = \frac{(400)^2}{60 + 60} \\ = 1,333.34 \text{ W.}$$

The power consumed by the three units is:

$$P = 4,000 \text{ W.}$$

3. For the star connection, $V_L = \sqrt{3} V_{ph}$:

$$V_{ph} = \frac{400}{\sqrt{3}} = 230.94 \text{ V.}$$

0. The power consumed by the two resistors in series is $P = \frac{V^2}{R} = \frac{(230.94)^2}{60 + 60}$:

$$p = 444.44 \text{ W.}$$

The power consumed by the three units is:

$$P = 1,333.33 \text{ W.}$$

1. The power consumed by the two resistors in parallel is:

$$P = \frac{(230.94)^2}{30}$$

The power consumed by the three units in series is:

$$P = 3 \times 1,777.77$$

$$= 5,333.32 \text{ W.}$$

4. The power is proportional to the square of the voltage. Hence, the voltage is 25%. So that, the power loss will be $\frac{1}{16}$ th of the values obtained as above.

ARC HEATING

If the high voltage is applied across an air gap, the air in the gap gets ionized under the influence of electrostatic forces and becomes conducting medium, current flows in the form of a continuous spark, known as *arc*. A very high voltage is required to establish an arc but very small voltage is sufficient to maintain it, across the air gap. The high voltage required for striking an arc can be obtained by using a step-up transformer fed from a variable AC supply.

Another method of striking the arc by using low voltage is by short circuiting the two electrodes momentarily and with drawing them back. Electrodes made up of carbon or graphite and are used in the arc furnaces when the temperature obtained is in the range of 3,000–3,500°C.

Electrodes used in the arc furnaces

Normally used electrodes in the arc furnaces are carbon electrodes, graphite electrodes, and self-baking electrodes. Usually the carbon and graphite electrodes are used and they can be selected based on their electrical conductivity insolubility, chemical inertness, mechanical strength, resistance to thermal shock, etc. The size of these electrodes may be 18–27 cm in diameter. The

carbon electrodes are used with small furnaces for manufacturing of ferro-alloys, aluminum phosphorous, etc. The self-baking electrodes are employed in the electrochemical furnaces and in the electrolytic production of aluminum.

The salient features of carbon and graphite electrodes are:

1. **Resistivity:** The graphite electrodes have low-specific resistance than the carbon electrodes, so the graphite required half in size for the same current resulting in easy replacement.
2. **Oxidation:** Graphite begins to oxides at 600°C where as carbon at 400°C.
3. **Electrode consumption:** For steel-melting furnaces, the consumption of the carbon electrodes is about 4.5 kg of electrodes per tonne of steel and 2.3–to 6.8 kg electrodes per tonne of steel for the graphite electrodes.
4. **Cost:** The graphite electrodes cost about twice as much per kg as the carbon electrodes. The choice of electrodes depends chiefly on the question of the total cost. In general, if the processes requiring large quantities of electrode, carbon is used but for other processes, the choice depends on local conditions.

Types of arc furnaces

There are two types of arc furnaces and they are:

1. direct arc furnace and
2. indirect arc furnace.

(i) Direct arc furnace

When supply is given to the electrodes, two arcs are established and current passes through the charge, as shown in Fig. 4.5. As the arc is in direct contact with the charge and heat is also produced by current flowing through the charge itself, it is known as *direct arc furnace*.

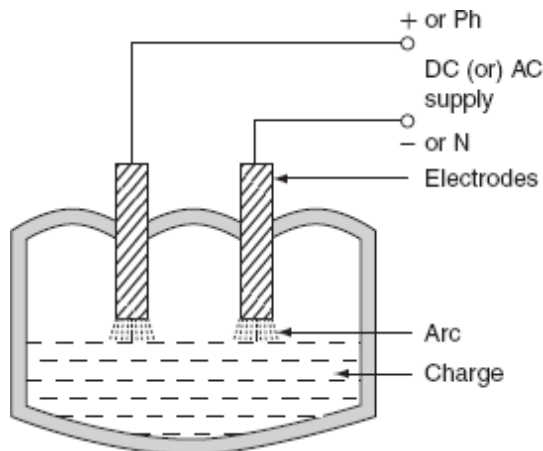

Fig. Direct arc furnace

If the available supply is DC or 1- ϕ , AC, two electrodes are sufficient, if the supply is 3- ϕ , AC, three electrodes are placed at three vertices of an equilateral triangle. The most important feature of the direct arc furnace is that the current flows through the charge, the stirring action is inherent due to the electromagnetic force setup by the current, such furnace is used for manufacturing alloy steel and gives purer product.

It is very simple and easy to control the composition of the final product during refining process operating the power factor of arc furnace is 0.8 lagging. For 1-ton furnace, the power required is about 200 kW and the energy consumed is 1.0 MWh/ton.

(ii) Indirect arc furnace

In indirect arc furnace, the arc strikes between two electrodes by bringing momentarily in contact and then with drawing them heat so developed, due to the striking of arc across air gap is transferred to charge is purely by radiation. A simple indirect arc furnace is shown in Fig. 4.6.

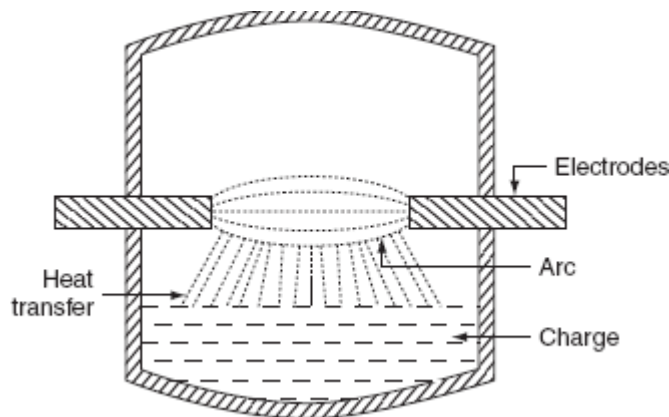

Fig. 4.6 Indirect arc furnace

These furnaces are usually 1- ϕ and hence their size is limited by the amount of one-phase load which can be taken from one point. There is no inherent stirring action provided in this furnace, as current does not flow through the charge and the furnace must be rocked mechanically. The electrodes are projected through this chamber at each end along the horizontal axis. This furnace

is also sometimes called as *rocking arc furnace*. The charge in this furnace is heated not only by radiation from the arc between electrode tips but also by conduction from the heated refractory during rocking action; so, the efficiency of such furnace is high. The arc is produced by bringing electrodes into solid contact and then withdrawing them; power input to the furnace is regulated by adjusting the arc length by moving the electrodes.

Even though it can be used in iron foundries where small quantities of iron are required frequently, the main application of this furnace is the melting of non-ferrous metals.

Example 4.6: Calculate the time taken to melt 5 ton of steel in three-phase arc furnace having the following data.

Current = 8,000 A	Resistance = 0.003 Ω
Arc voltage = 50 V	Reactance = 0.005 Ω
Latent heat = 8.89 kcal/kg	Specific heat = 0.12
Initial temperature = 18°C	Melting point = 1,370°C

The overall efficiency is 50%. Find also the power factor and the electrical efficiency of the furnace.

Solution:

The equivalent circuit of the furnace is shown in [Fig. P.4.1](#).

$$\text{Arc resistance per phase} = \frac{50}{8,000}$$

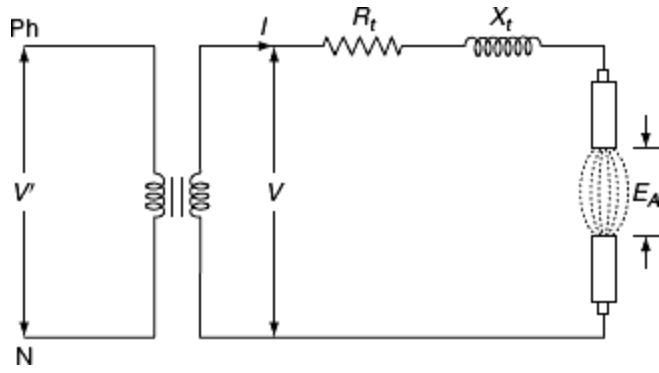

Fig. P.4.1 Equivalent circuit of arc furnace

$$R_A = 0.00625 \Omega.$$

Drop due to the resistance of transformer, $I R_t = 8,000 \times 0.003 = 24 \text{ V}$ and drop due to the reactance, $I X_t = 8,000 \times 0.005 = 40 \text{ V}$.

From the phasor diagram (Fig. P.4.2):

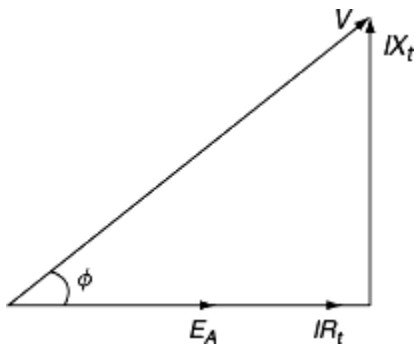

Fig. P.4.2 Phasor diagram

$$\begin{aligned}
 V &= \sqrt{(E_A + I R_t)^2 + (I X_t)^2} \\
 &= \sqrt{(50 + 24)^2 + (40)^2} \\
 &= 84.118 \text{ V.}
 \end{aligned}$$

From the phasor diagram:

$$\begin{aligned}
 \cos \phi &= \frac{E_A + I R_t}{V} \\
 &= \frac{50 + 24}{84.118} \\
 &= 0.879 \text{ lag.}
 \end{aligned}$$

The amount of heat required per kg of steel:

$$\begin{aligned}
 &= \text{Specific heat} \times (t_2 - t_1) + \text{latent heat} \\
 &= 0.12 \times (1,370 - 18) + 8.89 \\
 &= 171.13 \text{ kcal.}
 \end{aligned}$$

$$\begin{aligned}
 \text{The heat required for 5 ton} &= 5,000 \times 171.13 \\
 &= 855,650 \text{ kcal.}
 \end{aligned}$$

$$\begin{aligned}
 \text{The actual heat required} &= \frac{855,650 \times 1.162 \times 10^{-3}}{0.5} \\
 &= 1,988.53 \text{ kWh} \quad [\because 1 \text{ kcal} = 1.162 \times 10^{-3} \text{ kWh}].
 \end{aligned}$$

$$\begin{aligned}
 \text{Power input} &= 3 V I \cos \phi \times 10^{-3} \text{ kW} \\
 &= 3 \times 84.118 \times 8,000 \times 0.879 \times 10^{-3} \text{ kW} \\
 &= 1,774.55 \text{ kW.}
 \end{aligned}$$

$$\begin{aligned}
 \text{Time required} &= \frac{1,988.53}{1,774.55} = 1.12 \text{ hr} \\
 &= 67.2 \text{ min.}
 \end{aligned}$$

$$\begin{aligned}
 \text{The electrical efficiency of the furnace} &= \frac{3 \times 50 \times 8000}{1,774.55 \times 1,000} \times 100 \\
 &= 67.62\%.
 \end{aligned}$$

Example 4.7: A 100-kW Ajax Wyatt furnace works at a secondary voltage of 12 V at power factor 0.6 when fully charged. If the reactance presented by the charge remains constant but the resistance varies invert as the charge depth in the furnace; calculate the charge depth that produces maximum heating effect when the furnace is fully charged.

Solution:

Secondary power, $P = V_2 I_2 \cos \phi$

$$\begin{aligned} I_2 &= \frac{P}{V_2 \times \cos \phi} \\ &= \frac{100 \times 10^3}{12 \times 0.6} \\ &= 13.88 \text{ kA.} \end{aligned}$$

When the crucible is fully charged, then the secondary impedance is:

$$\begin{aligned} Z_2 &= \frac{V_2}{I_2} \\ &= \frac{12}{13.88 \times 10^3} \\ &= 0.864 \text{ m}\Omega. \end{aligned}$$

From the impedance triangle:

$$\begin{aligned}\cos \phi &= \frac{R_2}{Z_2} \\ &= Z_2 \cos \phi. \\ &= 0.864 \times 10^{-3} \times 0.6 \\ &= 0.5184 \text{ m}\Omega.\end{aligned}$$

The secondary reactance $X_2 = \sqrt{(Z_2)^2 - (R_2)^2}$

$$X_2 = \sqrt{(0.864 \times 10^{-3})^2 - (0.5184 \times 10^{-3})^2}$$

$$X_2 = 0.69 \text{ mm.}$$

Let ' H ' be the height of the crucible when the crucible is full of charge and ' H_m ' be the height of the charge at which maximum heating effect is possible.

$$\frac{H_m}{H} = h.$$

Given that the height of the charge is inversely proportional to the resistance. Let ' R_m ' be the maximum resistance at which maximum heating effect will be possible.

At $R_m = X_2$, the heat produced will be maximum.

$$\frac{H_m}{H} = \frac{R_2}{R_m} = h \quad \left[\because H_m \propto \frac{1}{R_m} \quad H \propto \frac{1}{R_2} \right]$$

$$\frac{H_m}{H} = \frac{R_2}{X_2} = h$$

$$h = \frac{0.5184 \times 10^{-3}}{0.69 \times 10^{-3}}$$

$$= 0.75$$

$$\frac{H_m}{H} = 0.75$$

$$H_m = 0.75H.$$

HIGH-FREQUENCY HEATING

The main difference between the power-frequency and the high-frequency heating is that in the conventional methods, the heat is transferred either by conduction convection or by radiation, but in the high-frequency heating methods, the electromagnetic energy converted into the heat energy inside the material.

The high-frequency heating can be applied to two types of materials. The heating of the conducting materials, such as ferro-magnetic and non-ferro-magnetic, is known as *induction heating*. The process of heating of the insulating materials is known as *dielectric heating*. The heat transfer by the conventional method is very low of the order of 0.5–20 W/sq. cm. And, the heat transfer rate by the high-frequency heating either by induction or by dielectric heating is as much as 10,000 W/sq. cm. Thus, the high-frequency heating is most important for tremendous speed of production.

INDUCTION HEATING

The induction heating process makes use of the currents induced by the electromagnetic action in the material to be heated. To develop sufficient amount of heat, the resistance of the material

must be low $\left(\because \text{power drawn} = \frac{V^2}{R} \right)$, which is possible only with the metals, and the voltage must be higher, which can be obtained by employing higher flux and higher frequency. Therefore, the magnetic materials can be heated than non-magnetic materials due to their high permeability.

In order to analyze the factors affecting induction heating, let us consider a circular disc to be heated carrying a current of ' I ' amps at a frequency ' f ' Hz. As shown in [Fig. 4.9](#).

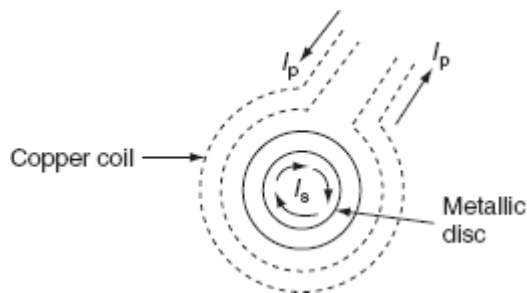

Fig. 4.9 Induction heating

Heat developed in the disc is depending upon the following factors.

- Primary coil current.
- The number of the turns of the coil.
- Supply frequency.
- The magnetic coupling between the coil and the disc.
- The high electrical resistivity of the disc.

If the charge to be heated is non-magnetic, then the heat developed is due to eddy current loss, whereas if it is magnetic material, there will be hysteresis loss in addition to eddy current loss. Both hysteresis and eddy current loss are depended upon frequency, but at high-frequency hysteresis, loss is very small as compared to eddy currents.

The depth of penetration of induced currents into the disc is given by:

$$d = \frac{1}{2\pi} \sqrt{\frac{\rho \times 10^9}{\mu f}} \text{ cm}$$

$$\text{i.e., } d \propto \frac{1}{\sqrt{f}},$$

where ρ is the specific resistance in $\Omega\text{-cm}$, f is the frequency in Hz, and μ is the permeability of the charge.

There are basically two types of induction furnaces and they are:

1. Core type or low-frequency induction furnace.
2. Coreless type or high-frequency induction furnace.

Core type furnace

The operating principle of the core type furnace is the electromagnetic induction. This furnace is operating just like a transformer. It is further classified as:

1. Direct core type.
2. Vertical core type.
3. Indirect core type.

(i) *Direct core type induction furnace*

The core type furnace is essentially a transformer in which the charge to be heated forms single-turn secondary circuit and is magnetically coupled to the primary by an iron core as shown in Fig. 4.10.

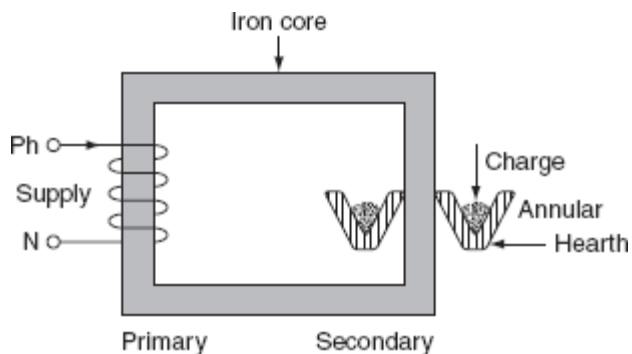

Fig. 4.10 Direct core type furnace

The furnace consists of a circular hearth in the form of a trough, which contains the charge to be melted in the form of an annular ring. This type of furnace has the following characteristics:

- This metal ring is quite large in diameter and is magnetically interlinked with primary winding, which is energized from an AC source. The magnetic coupling between primary and secondary is very weak; it results in high leakage reactance and low pf. To overcome the increase in leakage reactance, the furnace should be operated at low frequency of the order of 10 Hz.
- When there is no molten metal in the hearth, the secondary becomes open circuited thereby cutting of secondary current. Hence, to start the furnace, the molten metal has to be taken in the hearth to keep the secondary as short circuit.
- Furnace is operating at normal frequency, which causes turbulence and severe stirring action in the molten metal to avoid this difficulty, it is also necessary to operate the furnace at low frequency.
- In order to obtain low-frequency supply, separate motor-generator set (or) frequency changer is to be provided, which involves the extra cost.
- The crucible used for the charge is of odd shape and inconvenient from the metallurgical viewpoint.
- If current density exceeds about 500 A/cm^2 , it will produce high-electromagnetic forces in the molten metal and hence adjacent molecules repel each other, as they are in the same direction. The repulsion may cause the interruption of secondary circuit (formation of bubbles and voids); this effect is known as *pinch effect*.

The pinch effect is also dependent on frequency; at low frequency, this effect is negligible, and so it is necessary to operate the furnace at low frequency.

(ii) *Vertical core type induction furnace*

It is an improvement over the direct core type furnace, to overcome some of the disadvantages mentioned above. This type of furnace consists of a vertical core instead of horizontal core as shown in Fig. 4.11. It is also known as *Ajax–Wyatt induction furnace*.

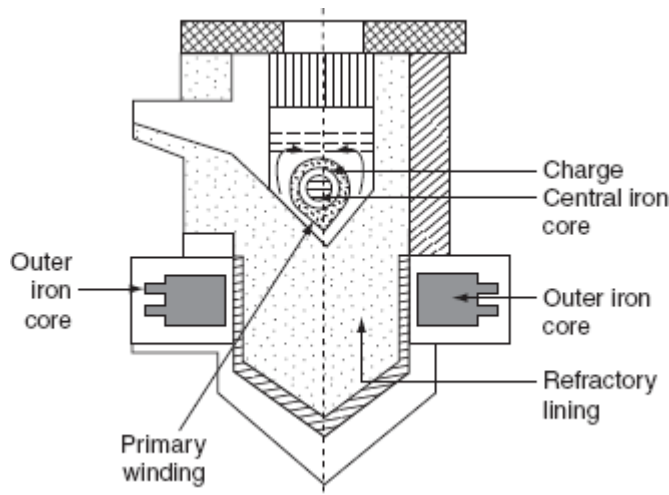

Fig. 4.11 Vertical core type furnace (Ajax–Wyatt induction furnace)

Vertical core avoids the pinch effect due to the weight of the charge in the main body of the crucible. The leakage reactance is comparatively low and the power factor is high as the magnetic coupling is high compared to direct core type.

There is a tendency of molten metal to accumulate at the bottom that keeps the secondary completed for a vertical core type furnace as it consists of narrow V-shaped channel.

The inside layer of furnace is lined depending upon the type charge used. Clay lining is used for yellow brass and an alloy of magnesia and alumina is used for red brass.

The top surface of the furnace is covered with insulating material, which can be removed for admitting the charge. Necessary hydraulic arrangements are usually made for tilting the furnace to take out the molten metal. Even though it is having complicated construction, it is operating at power factor of the order of 0.8–0.83. This furnace is normally used for the melting and refining of brass and non-ferrous metals.

Advantages

- Accurate temperature control and reduced metal losses.
- Absence of crucibles.
- Consistent performance and simple control.
- It is operating at high power factor.
- Pinch effect can be avoided.

(iii) Indirect core type furnace

This type of furnace is used for providing heat treatment to metal. A simple induction furnace with the absence of core is shown in [Fig. 4.12](#).

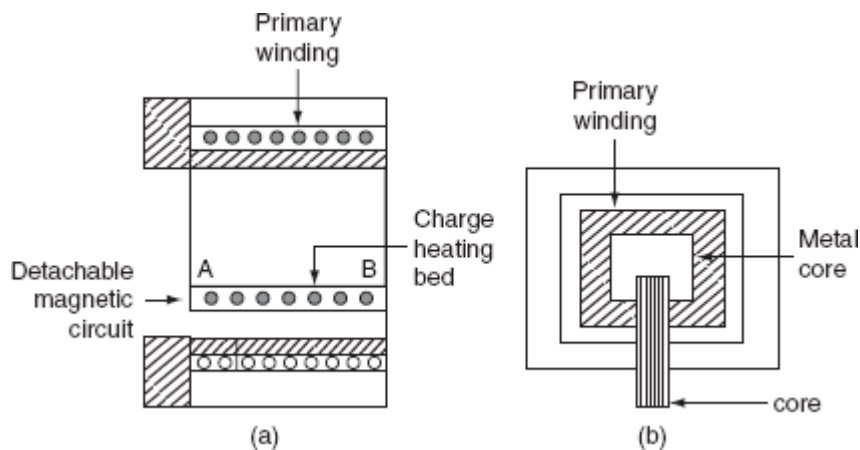

Fig. 4.12 Indirect core type furnace

The secondary winding itself forms the walls of the container or furnace and an iron core links both primary and secondary windings.

The heat produced in the secondary winding is transmitted to the charge by radiation. An oven of this type is in direct competition with ordinary resistance oven.

It consists of a magnetic circuit AB is made up of a special alloy and is kept inside the chamber of the furnace. This magnetic circuit loses its magnetic properties at certain temperature and regains them again when it is cooled to the same temperature.

When the oven reaches to critical temperature, the reluctance of the magnetic circuit increases many times and the inductive effect decreases thereby cutting off the supply heat. Thus, the

temperature of the furnace can be effectively controlled. The magnetic circuit 'AB' is detachable type that can be replaced by the other magnetic circuits having critical temperatures ranging between 400°C and 1,000°C. The furnace operates at a pf of around 0.8.

The main advantage of such furnace is wide variation of temperature control is possible.

Coreless type induction furnace

It is a simple furnace with the absence core is shown in [Fig. 4.13](#). In this furnace, heat developed in the charge due to eddy currents flowing through it.

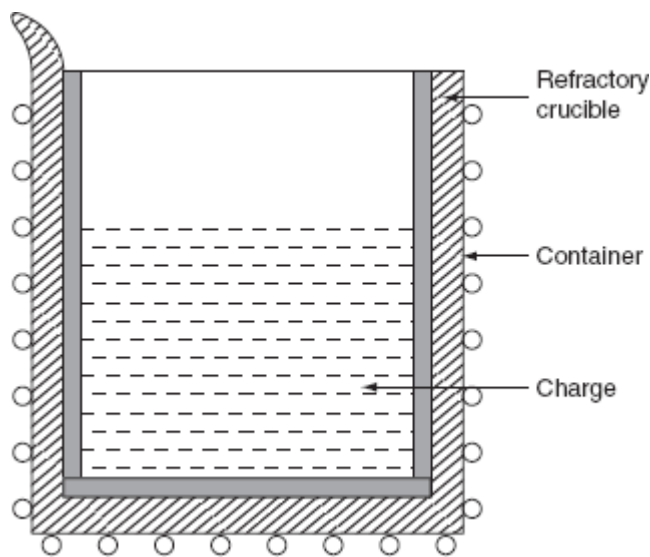

Fig. 4.13 Coreless induction furnace

The furnace consists of a refractory or ceramic crucible cylindrical in shape enclosed within a coil that forms primary of the transformer. The furnace also contains a conducting or non-conducting container that acts as secondary.

If the container is made up of conducting material, charge can be conducting or non-conducting; whereas, if the container is made up of non-conducting material, charge taken should have conducting properties.

When primary coils are excited by an alternating source, the flux set up by these coils induce the eddy currents in the charge. The direction of the resultant eddy current is in a direction opposite to the current in the primary coil. These currents heat the charge to melting point and they also set up electromagnetic forces that produce a stirring action to the charge.

∴ The eddy currents developed in any magnetic circuit are given as:

$$W_e \propto B_m^2 f^2,$$

where B_m is the maximum flux density (tesla), f is the frequency in (Hz), and W_e is the eddy current loss (watts).

In coreless furnace, the flux density will be low as there is no core. Hence, the primary supply should have high frequency for compensating the low flux density.

If it is operating at high frequency, due to the skin effect, it results copper loss, thereby increasing the temperature of the primary winding. This necessitates in artificial cooling. The coil, therefore, is made of hollow copper tube through which cold water is circulated.

Minimum stray magnetic field is maintained when designing coreless furnace, otherwise there will be considerable eddy current loss.

The selection of a suitable frequency of the primary current can be given by penetration formula. According to this:

$$t = \frac{1}{2\pi} \sqrt{\frac{\rho \times 10^9}{\mu f}}, \quad (4.11)$$

where ' t ' is the thickness up to which current in the metal has penetrated, ' ρ ' is the resistivity in Ω -cm, ' μ ' is the permeability of the material, and ' f ' is the frequency in Hz.

For the efficient operation, the ratio of the diameter of the charge (d) to the depth of the penetration of currents (t) should be more than '6', therefore let us take:

$$\frac{d}{t} = 8.$$

Substitute above in Equation (4.11).

$$f = \frac{16 \times \rho \times 10^9}{\pi^2 \mu d^2}. \quad (4.12)$$

Following are the advantages of coreless furnace over the other furnaces:

- Ease of control.
- Oxidation is reduced, as the time taken to reach the melting temperature is less.
- The eddy currents in the charge itself results in automatic stirring.
- The cost is less for the erection and operation.
- It can be used for heating and melting.
- Any shape of crucible can be used.
- It is suitable for intermittent operation.

Example 4.8: Determine the amount of energy required to melt 2 ton of zinc in 1 hr, if it operates at an efficiency of 70% specific heat of zinc is equals to 0.1. The latent heat of zinc = 26.67 kcal/kg, the melting point is 480°C, and the initial temperature is 25°C.

Solution:

Weight of zinc = $2 \times 1,000 = 2,000$ kg.

The heat required raising the temperature from 25°C to 480°C:

$$\begin{aligned} H &= w \times S \times (t_2 - t_1) \\ &= 2,000 \times 0.1 \times (480 - 25) \\ &= 91,000 \text{ kcal.} \end{aligned}$$

The heat required for melting:

$$\begin{aligned} &= w \times l \\ &= 2,000 \times 26.67 \\ &= 53,340 \text{ kcal.} \end{aligned}$$

$$\begin{aligned}\therefore \text{Total heat required} &= 91,000 + 53,340 \\ &= 144,340 \text{ kcal.}\end{aligned}$$

Since $4.18 \text{ J} = 1 \text{ cal}$ and $1 \text{ J/sec} = 1 \text{ W}$.

So, $1 \text{ cal} = 4.18 \text{ W-sec}$.

$$\begin{aligned}\text{Energy input} &= \frac{144,340 \times 10^3 \times 4.18}{10^3 \times 3,600 \times 0.70} \\ &= 239.42 \text{ kWh.}\end{aligned}$$

$$\text{Energy} = I^2 R t.$$

$$\begin{aligned}\text{Power} &= \frac{\text{energy}}{\text{time}} = \frac{239.42 \text{ kW}}{1} \\ &= 239.42 \text{ kW.}\end{aligned}$$

Example 4.9: A high-frequency induction furnace that takes 20 min to melt 1.9 kg of aluminum, the input to the furnace being 3 kW, and the initial temperature is 25°C . Then, determine the efficiency of the furnace.

The specific heat of aluminum = 0.212.

Melting point = 660°C .

The latent heat of the fusion of aluminum = 76.8 kcal/kg.

Solution:

$$\begin{aligned}\text{Total heat required} &= 1.90 \times 0.212 \times (60 - 25) + 1.9 \times 76.8 \\ &= 401.698 \text{ kcal.}\end{aligned}$$

$$\begin{aligned}\text{Heat required per hour} &= 401.698 \times \frac{60}{20} \\ &= 1,205.094 \text{ kcal.}\end{aligned}$$

$$\begin{aligned}\text{The power delivered to the charge} &= \frac{1,205.094}{860} \\ &= 1.401 \text{ kW.}\end{aligned}$$

$$\text{The efficiency of the furnace } \% \eta = \frac{1.401}{3} \times 100 .$$

DIELECTRIC HEATING

When non-metallic materials i.e., insulators such as wood, plastics, and china glass are subjected to high-voltage alternating electric field, the atoms get stresses, and due to interatomic friction caused by the repeated deformation and the rotation of atomic structure (polarization), heat is produced. This is known as dielectric loss. This dielectric loss in insulators corresponds to hysteresis loss in ferro-magnetic materials. This loss is due to the reversal of magnetism or magneto molecular friction. These losses developed in a material that has to be heated.

An atom of any material is neutral, since the central positive charge is equals to the negative charge. So that, the centers of positive and negative charges coincide as long as there is no external field is applied, as shown in Fig. (a). When this atom is subjected to the influence of the electric field, the positive charge of the nucleus is acted upon by some force in the direction of negative charges in the opposite direction. Therefore, the effective centers of both positive and negative charges no longer coincident as shown in Fig. (b). The electric charge of an atom equivalent to Fig.(b) is shown in Fig. (c).

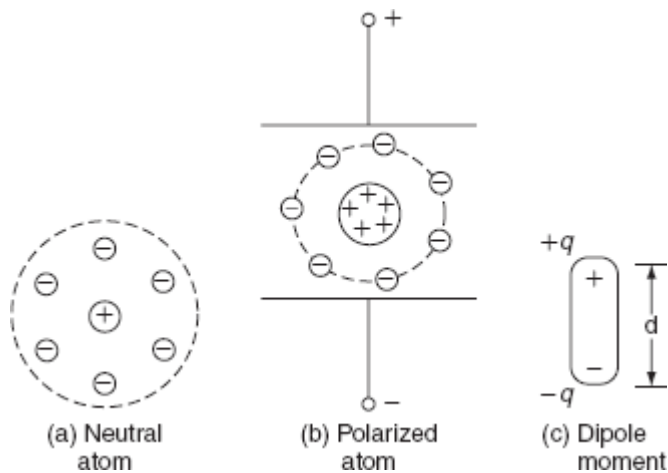

Fig. Polarization

This gives rise to an electric dipole moment equal to $P = q d$, where d is the distance between the two centers and q is the charge on the nucleus.

Now, the atom is said to be polarized atom. If we apply alternating voltage across the capacitor plate, we will get alternating electric field.

Electric dipoles will also try to change their orientation according to the direction of the impressed electric field. In doing so, some energy will be wasted as inter-atomic friction, which is called dielectric loss.

As there is no perfect conductor, so there is no perfect insulator. All the dielectric materials can be represented by a parallel combination of a leakage resistor 'R' and a capacitor 'C' as shown in Fig. 4.15 (a) and (b).

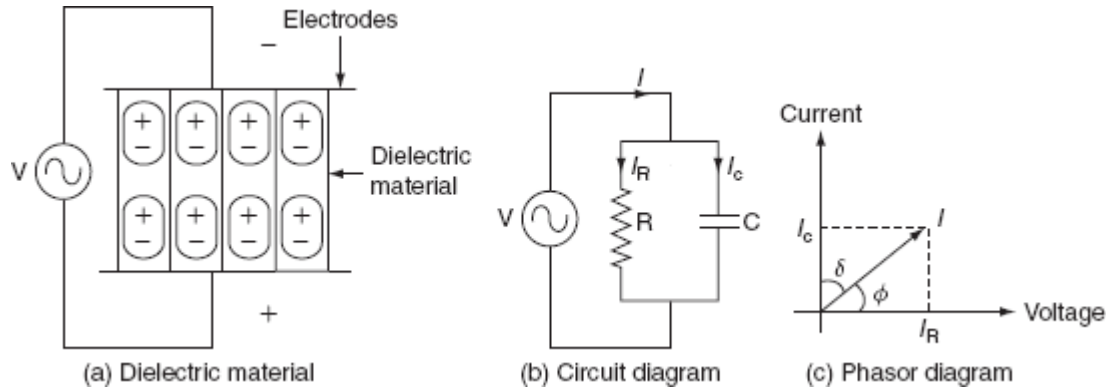

Fig. Dielectric heating

If an AC voltage is applied across a piece of insulator, an electric current flows; total current 'I' supposed to be made up of two components I_C and I_R , where I_C is the capacitive current leading the applied voltage by 90° and I_R is in phase with applied voltage as shown in Fig. 4.15(c).

$$\begin{aligned}
 \text{Dielectric loss, } P_L &= VI \cos \phi \\
 &= VI_R \quad [\because I_R = I \cos \phi] \\
 &= VI_C \tan \delta \quad \left[\because \tan \delta = \frac{I_R}{I_C} \right].
 \end{aligned}$$

$$\begin{aligned}
 V \cdot \left(\frac{V}{X_C} \right) \tan \delta & \quad \left[QI_C = \frac{V}{X_C} \right] \\
 = V^2 \omega C \tan \delta & \quad \quad \quad (4.13)
 \end{aligned}$$

$$= V^2 \times 2 \pi f \times \frac{\epsilon_0 \epsilon_r A}{d} \times \delta \text{ W} \quad (4.14)$$

where ‘ V ’ is the applied voltage in volts, ‘ f ’ is the supply frequency in Hz, ϵ_0 is the absolute permittivity of the medium = 8.854×10^{-12} F/m, ϵ_r is the relative permittivity of the medium = 1 for free space, A is the area of the plate or electrode (m^2), d is the thickness of the dielectric medium, and δ is the loss angle in radian.

From Equation (4.14):

$$P_L \propto V^2 \quad \text{and} \quad P_L \propto f. \quad (4.15)$$

Normally frequency used for dielectric heating is in the range of 1–40 MHz. The use of high voltage is also limited due to the breakdown voltage of thin dielectric that is to be heated, under normal conditions; the voltage gradient used is limited to 18 kV/cm.

The advantages of the dielectric heating

- The heating of the non-conducting materials is very rapid.
- The uniform heating of material is possible.
- Heat is produced in the whole mass of the material.

The applications of the dielectric heating

- The drying of paper, wood, etc.
- The gluing of wood.
- The heat-sealing of plastic sheets.
- The heating for the general processing such as coffee roasting and chocolate industry.
- The heating for the dehydration such as milk, cream, and vegetables.
- The preparation of thermoplastic resins.
- The heating of bones and tissues.
- Diathermy, i.e., the heat treatment for certain body pains and diseases, etc.
- The sterilization of absorbent cotton, bandages, etc.
- The processing of rubber, synthetic materials, chemicals, etc.

Example 4.12: A piece of insulating material is to be heated by dielectric heating. The size of the piece is $10 \times 10 \times 3 \text{ cm}^3$. A frequency of 30 mega cycles is used and the power absorbed is

400 W. Determine the voltage necessary for heating and the current that flows in the material. The material has a permittivity of 5 and a power factor of 0.05.

Solution:

The capacitance offered by the material is given by:

$$C = \frac{\epsilon_0 \epsilon_r A}{d},$$

where ϵ_0 is 8.854×10^{-12} , ϵ_r is 5, and A is area in $\text{m}^2 = 10 \times 10 \times 10^{-4} = 0.01 \text{ m}^2$.

$$\begin{aligned} \therefore C &= \frac{8.854 \times 10^{-12} \times 5 \times 0.01}{3 \times 10^{-2}} \\ &= 14.75 \text{ pF.} \end{aligned}$$

In the phasor diagram, δ is called the dielectric loss angle and ϕ is called the power factor angle.

From the phasor diagram (Fig. P.4.3):

$$\begin{aligned} \tan \delta &= \frac{I_R}{I_C} \\ &= \frac{V/R}{V \omega C} \\ \frac{V}{R} &= V \omega C \tan \delta. \end{aligned}$$

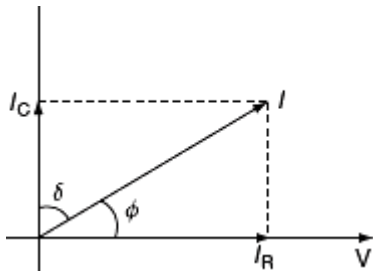

Fig. Phasor diagram

SHORT QUESTIONS AND ANSWERS

1. Give any two advantages of electric heating.

1. Electric heating equipment is cheaper; it does not require much skilled persons so maintenance cost is less.
2. In this heating, the temperature can be controlled and regulated accurately either manually or automatically.

What are the modes of the transfer of heat?

The modes of the transfer of heat are:

0. Conduction.

1. Convection.
2. Radiation.

What is an oven?

Oven is mean that a low-temperature heating chamber with provision for ventilation.

Define conduction.

The process of heat transfers from one part of a substance to another part without movement in the molecules of substance. The rate of conduction of heat along the substance depends upon temperature gradient.

Define convection.

The process of heat transfer takes place from one part to another part of a substance or a fluid due to the actual motion of the molecules. The rate of conduction of the heat depends mainly on the difference in the fluid density at different temperatures.

Define radiation.

The process of heat transfers from the source to the substance to be heated without heating the medium in between the source and the substance.

What are the essentials requirements of heating elements?

The materials used for heating element should have:

0. High-specific resistance.

1. High-melting point.
2. High-mechanical strength.
3. Free from oxidation.

What is the Stefan's formula for heat dissipation?

Stefan's law for heat dissipation is:

$$H = 5.72 \times 10^4 \text{ ke} \left[\left(\frac{T_1}{1,000} \right)^4 - \left(\frac{T_2}{1,000} \right)^4 \right] \text{ W/m}^2.$$

What are the causes of the failure of the heating elements?

The failure of the heating element may cause due to:

0. The formation of hotspots.
1. The oxidation of the element and the intermittency of operation.
2. The embitterment caused by gain growth
3. Contamination and corrosion.

What is meant by resistance heating?

The process of heating the charge or substance by the heat produced due to the resistance offered by the charge or heating element.

What is meant by induction heating?

The process of heating the material due to the heat developed by the currents induced in the material by electromagnetic induction process.

What is meant by dielectric heating?

The process of heating non-metallic materials, i.e., the insulators such as wood, plastics, and china clay due to the heat developed in the material when they are subjected to high voltage alternating electric field, the atoms get stresses and due to inter-atomic friction caused by the repeated deformation and rotation of atomic structure.

What are the various losses occurring in resistance oven?

The heat produced in the heating elements, not only raises the temperature of charge to desired value, but also used to overcome the losses occurring due to:

0. The heat used in raising the temperature of oven (or) furnace.
1. The heat used in raising the temperature of containers (or) carriers.
2. The heat conducted through the walls.
3. The heat loss due to the opening of oven door.

List out various methods of controlling the temperature of resistance heating.

The temperature of the furnaces can be controlled either by:

0. Varying the resistance of elements.
1. Varying the applied voltage to the elements or the current flowing through the elements
2. Varying the ratio of the on-and-off times of supply.

What are the types of arc furnaces?

There are two types of arc furnaces and they are:

0. Direct arc furnace.
1. Indirect arc furnace.

What is the condition for the maximum power output of electric arc furnace?

The condition for the maximum power output of electric arc furnace is:

$$R_A = \sqrt{(R_T + R_L)^2 + (X_T + X_L)^2} .$$

1. What is pinch effect?

The formation of bubbles and voids in the charge to be heated by the electromagnetic induction due to high-electromagnetic forces, which causes the interruption of secondary circuit. This effect is known as pinch effect.

2. What is high-frequency eddy current heating?

The process of heating any material by the heat developed due to the conversion of electromagnetic energy into heat energy.

3. How amount of heat is controlled in high-frequency eddy current heating?

The amount of heat is controlled by controlling the supply frequency and the flux density in high-frequency eddy current heating.

Electric Welding

INTRODUCTION

Welding is the process of joining two pieces of metal or non-metal together by heating them to their melting point. Filler metal may or may not be used to join two pieces. The physical and mechanical properties of a material to be welded such as melting temperature, density, thermal conductivity, and tensile strength take an important role in welding. Depending upon how the heat applied is created; we get different types of welding such as thermal welding, gas welding, and electric welding. Here in this chapter, we will discuss only about the electric welding and some introduction to other modern welding techniques. Welding is nowadays extensively used in automobile industry, pipe-line fabrication in thermal power plants, machine repair work, machine frames, etc.

ADVANTAGES AND DISADVANTAGES OF WELDING

Some of the advantages of welding are:

- Welding is the most economical method to permanently join two metal parts.
- It provides design flexibility.
- Welding equipment is not so costly.
- It joins all the commercial metals.
- Both similar and dissimilar metals can be joined by welding.
- Portable welding equipment are available.

Some of the disadvantages of welding are:

- Welding gives out harmful radiations and fumes.
- Welding needs internal inspection.
- If welding is not done carefully, it may result in the distortion of workpiece.
- Skilled welding is necessary to produce good welding.

ELECTRIC WELDING

It is defined as the process of joining two metal pieces, in which the electrical energy is used to generate heat at the point of welding in order to melt the joint.

The classification of electric welding process is shown in fig.

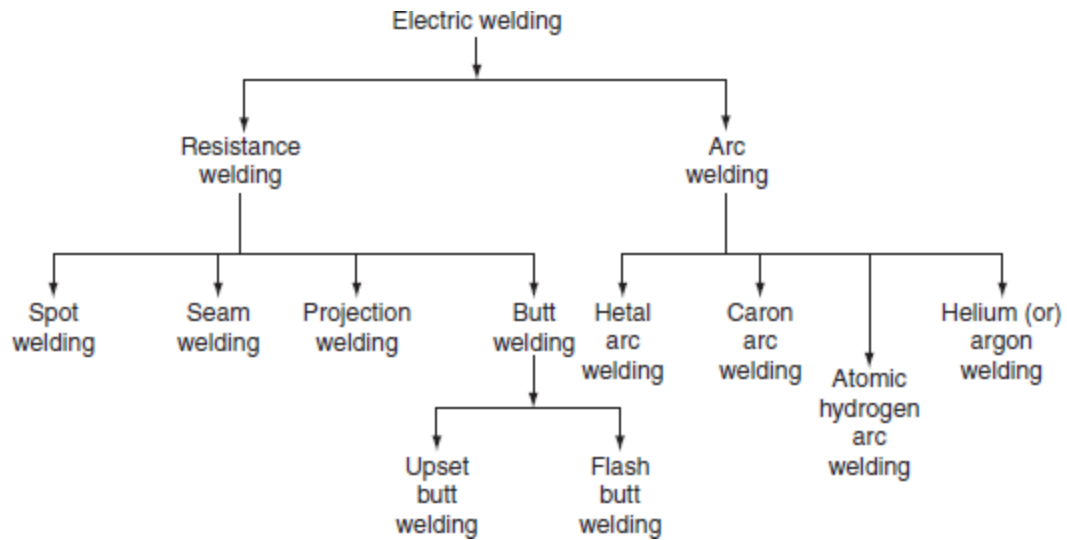

Fig. Classification of electric welding

The selection of proper welding process depends on the following factors.

- The type of metal to be joined.
- The techniques of welding adopted.
- The cost of equipment used.
- The nature of products to be fabricated.

RESISTANCE WELDING

Resistance welding is the process of joining two metals together by the heat produced due to the resistance offered to the flow of electric current at the junctions of two metals. The heat produced by the resistance to the flow of current is given by:

$$H = I^2Rt,$$

where I is the current through the electrodes, R is the contact resistance of the interface, and t is the time for which current flows.

Here, the total resistance offered to the flow of current is made up of:

1. The resistance of current path in the work.
2. The resistance between the contact surfaces of the parts being welded.
3. The resistance between electrodes and the surface of parts being welded.

In this process of welding, the heat developed at the contact area between the pieces to be welded reduces the metal to plastic state or liquid state, then the pieces are pressed under high mechanical pressure to complete the weld. The electrical voltage input to the welding varies in between 4 and 12 V depending upon area, thickness, composition, etc. and usually power ranges from about 60 to 180 W for each sq. mm of area.

Any desired combination of voltage and current can be obtained by means of a suitable transformer in AC; hence, AC is found to be most suitable for the resistance welding. The magnitude of current is controlled by changing the primary voltage of the welding transformer, which can be done by using an auto-transformer or a tap-changing transformer. Automatic arrangements are provided to switch off the supply after a pre-determined time from applying the pressure, why because the duration of the current flow through the work is very important in the resistance welding.

The electrical circuit diagram for the resistance welding is shown in Fig. 5.2. This method of welding consists of a tap-changing transformer, a clamping device for holding the metal pieces, and some sort of mechanical arrangement for forcing the pieces to form a complete weld.

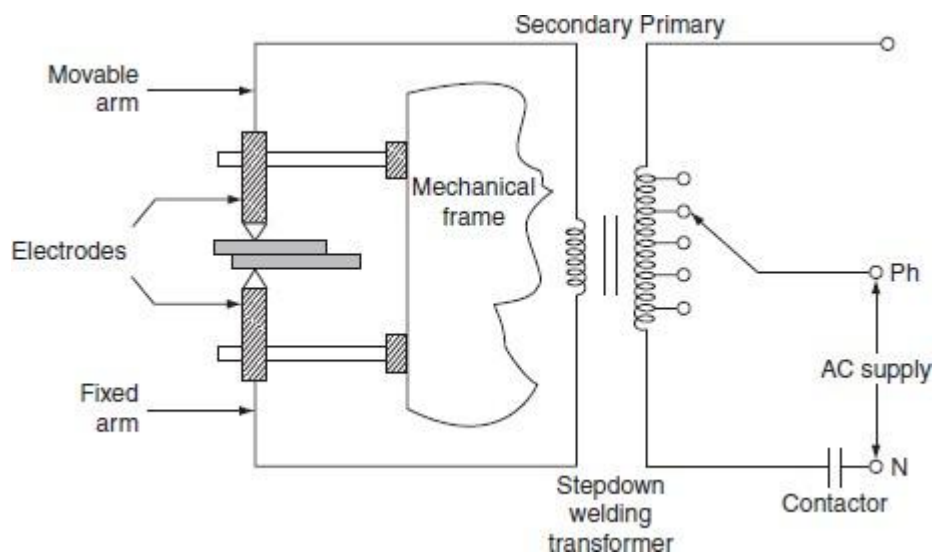

Fig. Electric circuit for resistance welding

Advantages

- Welding process is rapid and simple.
- Localized heating is possible, if required.
- No need of using filler metal.
- Both similar and dissimilar metals can be welded.
- Comparatively lesser skill is required.
- Maintenance cost is less.
- It can be employed for mass production.

However, the resistance welding has got some drawbacks and they are:

- Initial cost is very high.
- High maintenance cost.
- The workpiece with heavier thickness cannot be welded, since it requires high input current.

Applications

- It is used by many industries manufacturing products made up of thinner gauge metals.
- It is used for the manufacturing of tubes and smaller structural sections.

Types of resistance welding

Depending upon the method of weld obtained and the type of electrodes used, the resistance welding is classified as:

1. Spot welding.
2. Seam welding.
3. Projection welding.
4. Butt welding.

(i) Spot welding

Spot welding means the joining of two metal sheets and fusing them together between copper electrode tips at suitably spaced intervals by means of heavy electric current passed through the electrodes as shown in Fig. 5.3.

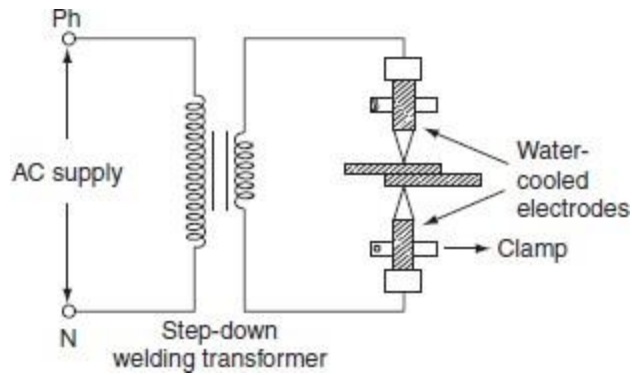

Fig. 5.3 Spot welding

This type of joint formed by the spot welding provides mechanical strength and not air or water tight, for such welding it is necessary to localize the welding current and to apply sufficient pressure on the sheet to be welded. The electrodes are made up of copper or copper alloy and are water cooled. The welding current varies widely depending upon the thickness and composition of the plates. It varies from 1,000 to 10,000 A, and voltage between the electrodes is usually less than 2 V. The period of the flow of current varies widely depending upon the thickness of sheets to be joined. A step-down transformer is used to reduce a high-voltage and low-current supply to low-voltage and high-current supply required. Since the heat developed being proportional to the product of welding time and square of the current. Good weld can be obtained by low currents for longer duration and high currents for shorter duration; longer welding time usually produces stronger weld but it involves high energy expenditure, electrode maintenance, and lot of distortion of workpiece.

When voltage applied across the electrode, the flow of current will generate heat at the three junctions, i.e., heat developed, between the two electrode tips and workpiece, between the two workpieces to be joined as shown in [Fig. 3.3](#). The generation of heat at junctions 1 and 3 will effect electrode sticking and melt through holes, the prevention of electrode striking is achieved by:

1. Using water-cooled electrodes shown in [Fig. 5.4](#). By avoiding the heating of junctions 1 and 3 electrodes in which cold water circulated continuously as shown in [Fig. 5.3](#).
2. The material used for electrode should have high electrical and thermal conductivity. Spot welding is widely used for automatic welding process, for joining automobile parts, joining and fabricating sheet metal structure, etc.

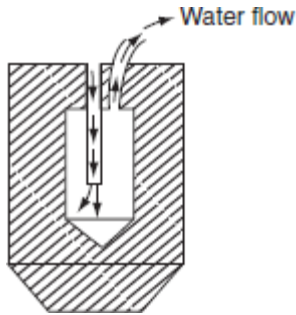

Fig. Water cooled electrode

(ii) Seam welding

Seam welding is nothing but the series of continuous spot welding. If number spots obtained by spot welding are placed very closely that they can overlap, it gives rise to seam welding.

In this welding, continuous spot welds can be formed by using wheel type or roller electrodes instead of tipped electrodes as shown in Fig. 5.5.

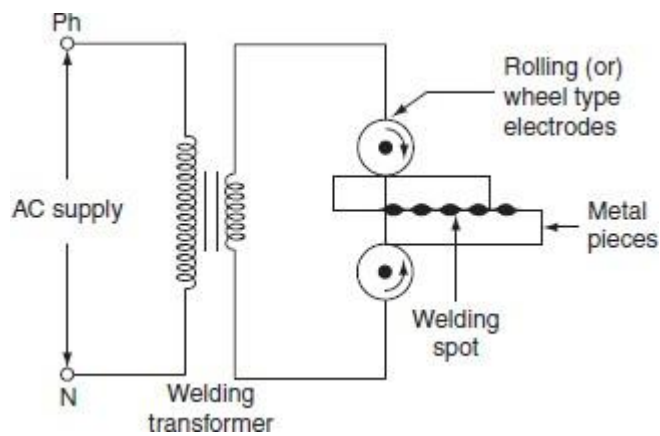

Fig. 5.5 Seam welding

Seam welding is obtained by keeping the job under electrodes. When these wheel type electrodes travel over the metal pieces which are under pressure, the current passing between them heats the two metal pieces to the plastic state and results into continuous spot welds.

In this welding, the contact area of electrodes should be small, which will localize the current pressure to the welding point. After forming weld at one point, the weld so obtained can be cooled by splashing water over the job by using cooling jets.

In general, it is not satisfactory to make a continuous weld, for which the flow of continuous current build up high heat that causes burning and wrapping of the metal piece. To avoid this difficulty, an interrupter is provided on the circuit which turns on supply for a period sufficient to heat the welding point. The series of weld spots depends upon the number of welding current pulses.

The two forms of welding currents are shown in Fig. 5.6(a) and (b).

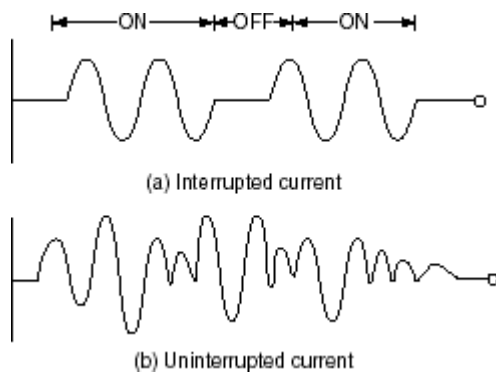

Fig. 5.6 Welding current

Welding cannot be made satisfactorily by using uninterrupted or un-modulated current, which builds up high heat as the welding progress; this will over heat the workpiece and cause distortion.

Seam welding is very important, as it provides leak proof joints. It is usually employed in welding of pressure tanks, transformers, condensers, evaporators, air craft tanks, refrigerators, varnish containers, etc.

(iii) Projection welding

It is a modified form of the spot welding. In the projection welding, both current and pressure are localized to the welding points as in the spot welding. But the only difference in the projection welding is the high mechanical pressure applied on the metal pieces to be welded, after the formation of weld. The electrodes used for such welding are flat metal plates known as *platens*.

The two pieces of base metal to be weld are held together in between the two platens, one is movable and the other is fixed, as shown in Fig. 5.7.

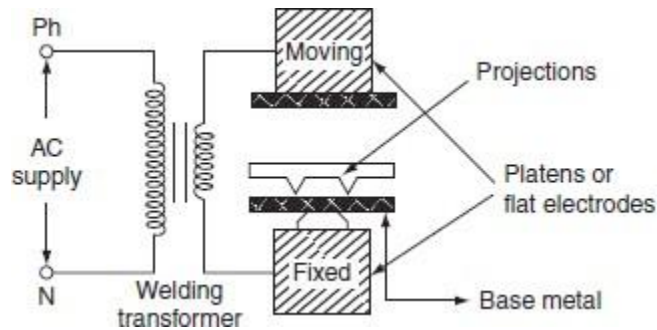

Fig. 5.7 Projection welding

One of the two pieces of metal is run through a machine that makes the bumps or projections of required shape and size in the metal. As current flows through the two metal parts to be welded, which heat up and melt. These weld points soon reach the plastic state, and the projection touches the metal then force applied by the two flat electrodes forms the complete weld.

The projection welding needs no protective atmosphere as in the spot welding to produce successful results. This welding process reduces the amount of current and pressure in order to join two metal surfaces, so that there is less chance of distortion of the surrounding areas of the weld zone. Due to this reason, it has been incorporated into many manufacturing process.

The projection welding has the following advantages over the spot welding.

- Simplicity in welding process.
- It is easy to weld some of the parts where the spot welding is not possible.
- It is possible to join several welding points.
- Welds are located automatically by the position of projection.
- As the electrodes used in the projection welding are flat type, the contact area over the projection is sufficient.

This type of welding is usually employed on punched, formed, or stamped parts where the projection automatically exists. The projection welding is particularly employed for mass production work, i.e., welding of refrigerators, condensers, crossed wire welding, refrigerator racks, grills, etc.

(iv) *Butt welding*

Butt welding is similar to the spot welding; however, the only difference is, in butt welding, instead of electrodes the metal parts that are to be joined or butted together are connected to the supply.

The three basic types of the butt welding process are:

1. Upset butt welding.
2. Flash butt welding.
3. Percussion butt welding.

(a) *Upset butt welding*

In upset welding, the two metal parts to be welded are joined end to end and are connected across the secondary of a welding transformer as shown in Fig. 5.8.

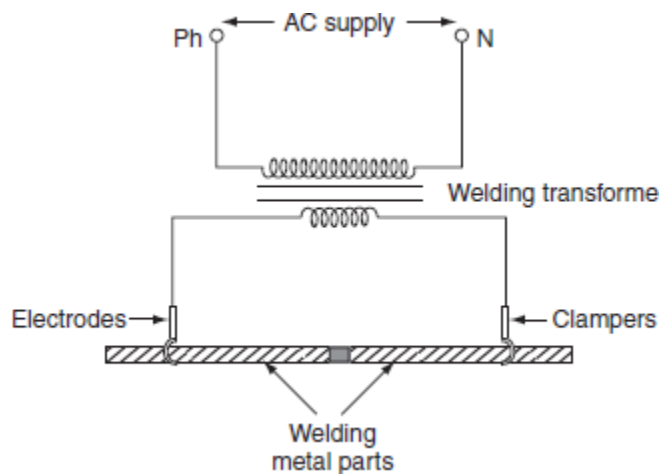

Fig. 5.8 Upset butt welding

Due to the contact resistance of the metals to be welded, heating effect is generated in this welding. When current is made to flow through the two electrodes, heat will develop due to the contact resistance of the two pieces and then melts. By applying high mechanical pressure either manually or by toggle mechanism, the two metal pieces are pressed. When jaw-type electrodes are used that introduce the high currents without treating any hot spot on the job.

This type of welding is usually employed for welding of rods, pipes, and wires and for joining metal parts end to end.

(b) Flash butt welding

Flash butt welding is a combination of resistance, arc, and pressure welding. This method of welding is mainly used in the production welding. A simple flash butt welding arrangement is shown in Fig. 5.9.

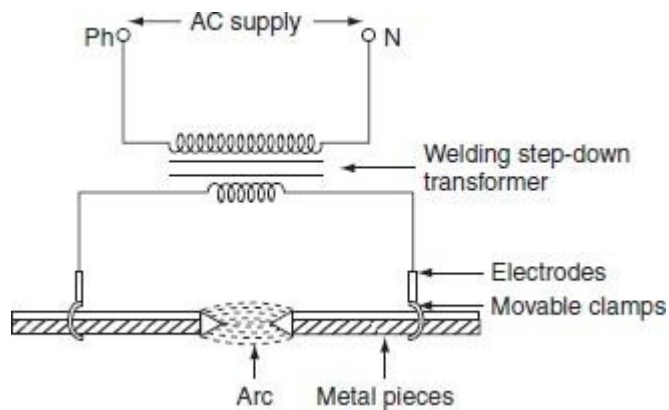

Fig. 5.9 Flash butt welding

In this method of welding, the two pieces to be welded are brought very nearer to each other under light mechanical pressure. These two pieces are placed in a conducting movable clamps. When high current is passed through the two metal pieces and they are separated by some distance, then arc established between them. This arc or flashing is allowed till the ends of the workpieces reach melting temperature, the supply will be switched off and the pieces are rapidly brought together under light pressure. As the pieces are moved together, the fused metal and slag come out of the joint making a good solid joint.

Following are the advantages of the flash butt welding over the upset welding.

- Less requirement of power.
- When the surfaces being joined, it requires only less attention.
- Weld obtained is so clean and pure; due to the foreign metals appearing on the surfaces will burn due to flash or arc.

(c) Percussion welding

It is a form of the flash butt welding, where high current of short duration is employed using stored energy principle. This is a self-timing spot welding method.

Percussion welding arrangement consists of one fixed holder and the other one is movable. The pieces to be welded are held apart, with the help of two holders, when the movable clamp is released, it moves rapidly carrying the piece to be welded. There is a sudden discharge of electrical energy, which establishes an arc between the two surfaces and heating them to their melting temperature, when the two pieces are separated by a distance of 1.5 mm apart. As the pieces come in contact with each other under heavy pressure, the arc is extinguished due to the percussion blow of the two parts and the force between them affects the weld. The percussion welding can be obtained in two methods; one is capacitor energy storage system and the other is magnetic energy storage system. The capacitor discharge circuit for percussion welding is shown in Fig. 5.10.

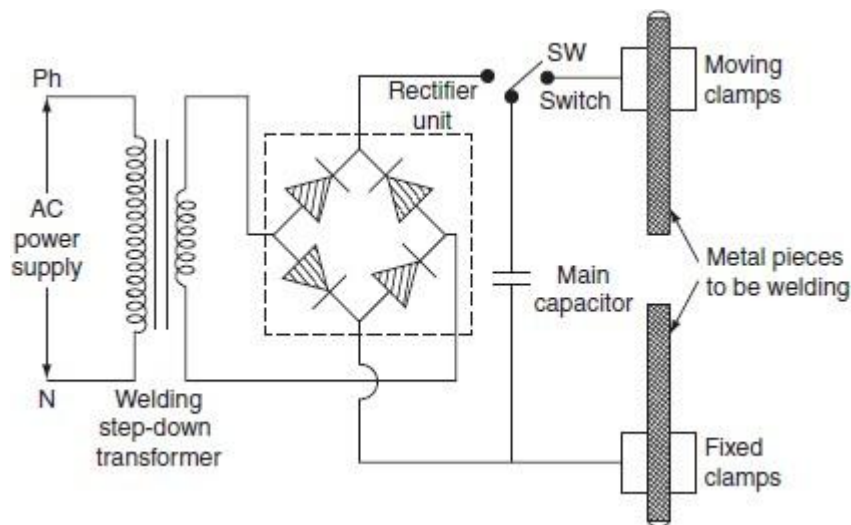

Fig. 5.10 Capacitor discharge circuit for percussion welding

The capacitor 'C' is charged to about 3,000 V from a controlled rectifier. The capacitor is connected to the primary of welding transformer through the switch and will discharge. This discharge will produce high transient current in the secondary to join the two metal pieces.

Percussion welding is difficult to obtain uniform flashing of the metal part areas of the cross-section greater than 3 sq. cm. Advantage of this welding is so fast, extremely shallow of heating is

obtained with a span of about 0.1 sec. It can be used for welding a large number of dissimilar metals.

Applications

- It is useful for welding satellite tips to tools, silver contact tips to copper, cast iron to steel, etc.
- Commonly used for electrical contacts.
- The metals such as copper alloys, aluminum alloys, and nickel alloys are percussion welded.

CHOICE OF WELDING TIME

The successful welding operation mainly depends upon three factors and they are:

1. Welding time.
2. Welding current.
3. Welding pressure.

Figure 5.11 shows how the energy input to the welding process, welding strength, and welding current vary with welding time.

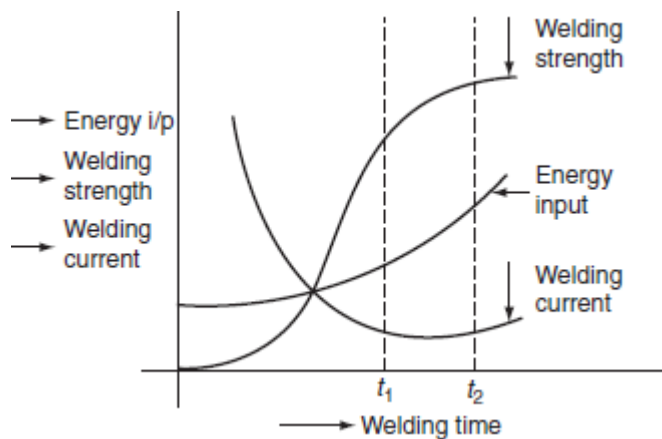

Fig. 5.11 Performance characteristics of electric welding

The heat developed during welding process is given by $H = I^2Rt$. Here both welding current and welding time are critical variables.

Greater the welding current, the shorter the welding time required is; usually longer welding time produces stronger weld but there is lot of distortion of workpiece and high energy expenditure. From Fig. 5.11, it is to be noted that, from 0 to t_1 sec, there is appreciable increase in welding strength, but after t_2 sec, the increase in the welding time does not appreciably result in the increase in strength; therefore, ' t_2 ' is the optimum welding time. This optimum time varies with the thickness of the material. The optimum times of material (sheet steel) with different thickness are given as:

Dimensions of material	Optimum time
2 × 24 SWG	8 cycles
2 × 14 SWG	20 cycles
2¼"	2 sec

Therefore, from the above discussion, it is observed that shorter welding times with strength and economy are always preferable.

Electromagnetic storage welding circuit is shown in Fig. 5.12. In this type of welding, the energy stored in the magnetic circuit is used in the welding operation.

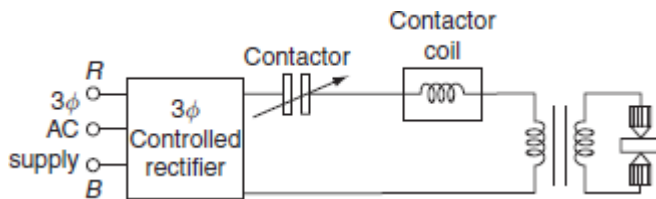

Fig. 5.12 Magnetic energy storage welding circuit

In this system, rectifier is fed from AC supply, which is converted to DC, the DC voltage of rectifier is controlled in such a way that, voltage induced in the primary without causing large current in the secondary of transformer on opening the contactor switch, DC on longer flows, there is rapid collapse of magnetic field, which induces very high current in the secondary of a transformer. Induced currents in the secondary of the transformer flow through the electrodes that develop heat at the surface of the metal and so forming the complete weld.

ELECTRIC ARC WELDING

Electric arc welding is the process of joining two metallic pieces or melting of metal is obtained due to the heat developed by an arc struck between an electrode and the metal to be welded or between the two electrodes as shown in [Fig. 5.13 \(a\)](#).

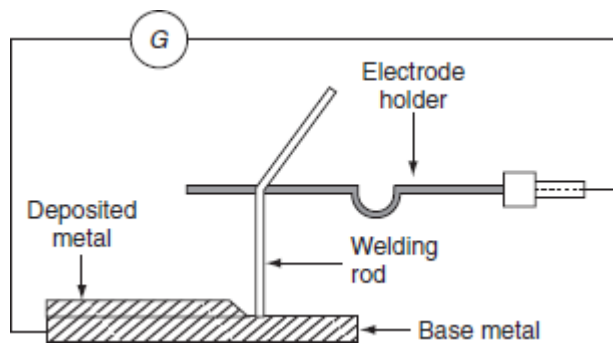

Fig. Arrangement of electric welding equipment

In this process, an electric arc is produced by bringing two conductors (electrode and metal piece) connected to a suitable source of electric current, momentarily in contact and then separated by a small gap, arc blows due to the ionization and give intense heat.

The heat so developed is utilized to melt the part of workpiece and filler metal and thus forms the weld.

In this method of welding, no mechanical pressure is employed; therefore, this type of welding is also known as '*non-pressure welding*'.

The length of the arc required for welding depends upon the following factors:

- The surface coating and the type of electrodes used.
- The position of welding.
- The amount of current used.

When the supply is given across the conductors separated by some distance apart, the air gap present between the two conductors gets ionized, as the arc welding is in progress, the ionization of the arc path and its surrounding area increases. This increase in ionization decreases the resistance of the path. Thus, current increases with the decrease in voltage of arc. This $V-I$ characteristic of an arc is shown in [Fig. \(b\)](#), it also known as *negative resistance characteristics of an arc*. Thus, it will be seen that this decrease in resistance with increase in current does not

remain the arc steadily. This difficulty can be avoided, with the supply, it should fall rapidly with the increase in the current so that any further increase in the current is restricted.

For the arc welding, the temperature of the arc should be $3,500^{\circ}\text{C}$. At this temperature, mechanical pressure for melting is not required. Both AC and DC can be used in the arc welding. Usually 70–100 V on AC supply and 50–60 V on DC supply system is sufficient to strike the arc in the air gap between the electrodes. Once the arc is struck, 20–30 V is only required to maintain it.

However, in certain cases, there is any danger of electric shock to the operator, low voltage should be used for the welding purpose. Thus, DC arc welding of low voltage is generally preferred.

Electric arc welding is extensively used for the joining of metal parts, the repair of fractured casting, and the fillings by the deposition of new metal on base metal, etc.

Various types of electric arc welding are:

1. Carbon arc welding.
2. Metal arc welding.
3. Atomic hydrogen arc welding.
4. Inert gas metal arc welding.
5. Submerged arc welding.

Carbon arc welding

It is one of the processes of arc welding in which arc is struck between two carbon electrodes or the carbon electrode and the base metal. The simple arrangement of the carbon arc welding is shown in [Fig. 5.14](#).

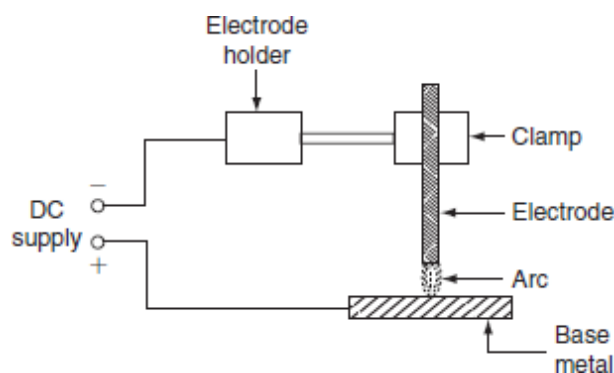

Fig. Carbon arc welding

In this process of welding, the electrodes are placed in an electrode holder used as negative electrode and the base metal being welded as positive. Unless, the electrode is negative relative to the work, due to high temperature, there is a tendency of the particles of carbon will fuse and mix up with the base metal, which causes brittleness; DC is preferred for carbon arc welding since there is no fixed polarity maintained in case of AC.

In the carbon arc welding, carbon or graphite rods are used as electrode. Due to longer life and low resistance, graphite electrodes are used, and thus capable of conducting more current. The arc produced between electrode and base metal; heat the metal to the melting temperature, on the negative electrode is 3,200°C and on the positive electrode is 3,900°C.

This process of welding is normally employed where addition of filler metal is not required. The carbon arc is easy to maintain, and also the length of the arc can be easily varied. One major problem with carbon arc is its instability which can be overcome by using an inductor in the electrode of 2.5-cm diameter and with the current of about of 500–800 A employed to deposit large amount of filler metal on the base metal.

Filler metal and flux may not be used depending upon the type of joint and material to be welded.

Advantages

- The heat developed during the welding can be easily controlled by adjusting the length of the arc.
- It is quite clean, simple, and less expensive when compared to other welding process.
- Easily adoptable for automation.
- Both the ferrous and the non-ferrous metals can be welded.

Disadvantages

- Input current required in this welding, for the workpiece to rise its temperature to melting/welding temperature, is approximately double the metal arc welding.
- In case of the ferrous metal, there is a chance of disintegrating the carbon at high temperature and transfer to the weld, which causes harder weld deposit and brittleness.
- A separate filler rod has to be used if any filler metal is required.

Applications

- It can be employed for the welding of stainless steel with thinner gauges.
- Useful for the welding of thin high-grade nickel alloys and for galvanized sheets using copper silicon manganese alloy filler metal.

Metal arc welding

In metal arc welding, the electrodes used must be of the same metal as that of the work-piece to be welded. The electrode itself forms the filler metal. An electric arc is struck by bringing the electrode connected to a suitable source of electric current, momentarily in contact with the workpieces to be welded and withdrawn apart. The circuit diagram for the metal arc welding is shown in [Fig. 5.15](#).

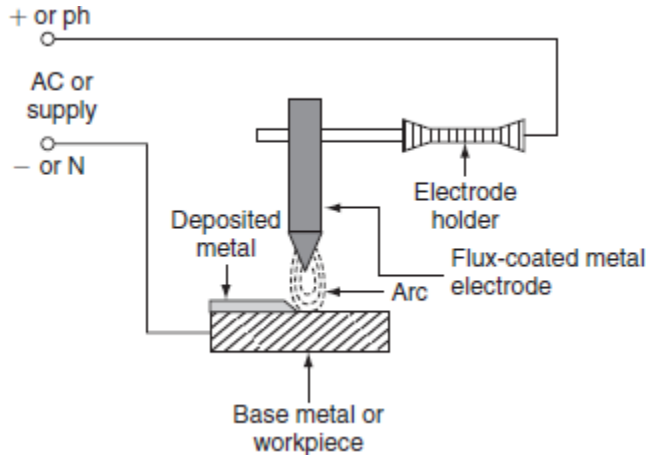

Fig. 5.15 Metal arc welding

The arc produced between the workpiece and the electrode results high temperature of the order of about $2,400^{\circ}\text{C}$ at negative metal electrode and $2,600^{\circ}\text{C}$ at positive base metal or workpiece.

This high temperature of the arc melts the metal as well as the tip of the electrode, then the electrode melts and deposited over the surface of the workpiece, forms complete weld.

Both AC and DC can be used for the metal arc welding. The voltage required for the DC metal arc welding is about 50–60 V and for the AC metal arc welding is about 80–90 V

In order to maintain the voltage drop across the arc less than 13 V, the arc length should be kept as small as possible, otherwise the weld will be brittle. The current required for the welding varies from 10 to 500 A depending upon the type of work to be welded.

The main disadvantage in the DC metal arc welding is the presence of arc blow, i.e., distortion of arc stream from the intended path due to the magnetic forces of the non-uniform magnetic field with AC arc blow is considerably reduced. For obtaining good weld, the flux-coated

electrodes must be used, so the metal which is melted is covered with slag produces a non-oxidizing gas or a molten slag to cover the weld, and also stabilizes the arc.

Atomic hydrogen arc welding

In atomic hydrogen arc welding, shown in Fig. 5.16, the heat for the welding process is produced from an electric arc struck between two tungsten electrodes in an atmosphere of hydrogen. Here, hydrogen serves mainly two functions; one acts as a protective screen for the arc and the other acts as a cooling agent for the glowing tungsten electrode tips. As the hydrogen gas passes through the arc, the hydrogen molecules are broken up into atoms, absorbs heat from the glowing tungsten electrodes so that these are cooled.

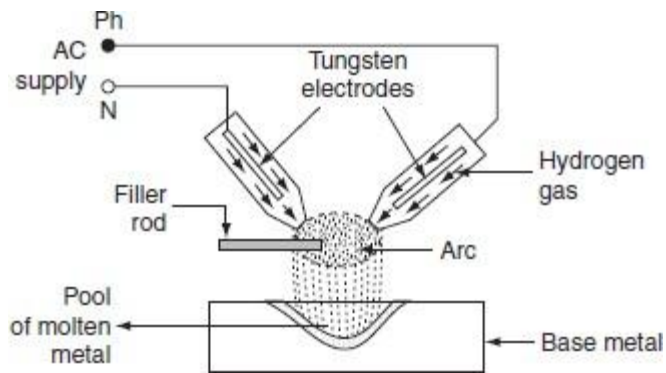

Fig. 5.16 Atomic hydrogen arc welding

But, when the atoms of hydrogen recombine into molecules outside the arc, a large amount of heat is liberated. This extraheat is added to the intense heat of arc, which produces a temperature of about 4,000°C that is sufficient to melt the surfaces to be welded, together with the filler rod if used. Moreover hydrogen includes oxygen and some other gases that might combine with the molten metal and forms oxides and other impurities. Hydrogen also removes oxides from the surface of workpiece. Thus, this process is capable of producing strong, uniform, smooth, and ductile welds.

In the atomic hydrogen arc welding, the arc is maintained between the two non-consumable tungsten electrodes under a pressure of about 0.5 kg/cm². In order to obtain equal consumption of electrodes, AC supply is used. Arc currents up to 150 A can be used. High voltage about 300 V is applied for this welding through a transformer. For striking the arc between the electrodes the open circuit voltage required varies from 80 to 100 V.

As the atomic hydrogen welding is too expensive, it is usually employed for welding alloy steel, carbon steel, stainless steel, aluminum, etc.

Inert gas metal arc welding

It is a gas-shielded metal arc welding, in which an electric arc is struck between tungsten electrode and workpiece to be welded. Filler metal may be introduced separately into the arc if required. A welding gun, which carries a nozzle, through this nozzle, inert gas such as beryllium or argon is blown around the arc and onto the weld, as shown in [Fig. 5.17](#). As both beryllium and argon are chemically inert, so the molten metal is protected from the action of the atmosphere by an envelope of chemically reducing or inert gas.

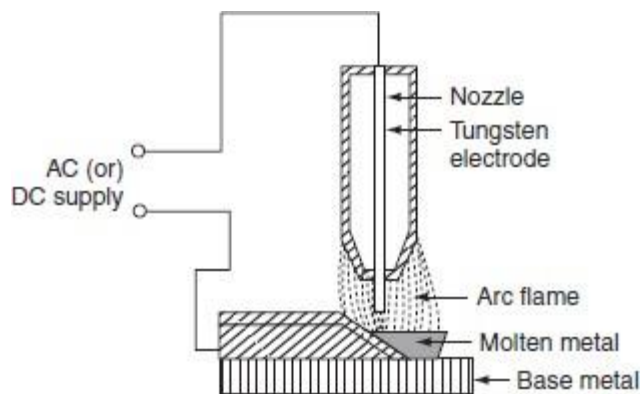

Fig. 5.17 Inert gas metal are welding

As molten metal has an affinity for oxygen and nitrogen, if exposed to the atmosphere, thereby forming their oxides and nitrides, which makes weld leaky and brittle.

Thus, several methods of shielding have been employed. With the use of flux coating electrodes or by pumping, the inert gases around the arc produces a slag that floats on the top of molten metal and produces an envelope of inert gas around the arc and the weld.

Advantages

- Flux is not required since inert gas envelope protects the molten metal without forming oxides and nitrates so the weld is smooth, uniform, and ductile.
- Distortion of the work is minimum because the concentration of heat is possible.

Applications

- The welding is employed for light alloys, stainless steel, etc.
- The welding of non-ferrous metal such as copper, aluminum, etc.

SUBMERGED ARC WELDING

It is an arc welding process, in which the arc column is established between above metal electrode and the workpiece. Electric arc and molten pool are shielded by blanket of granular flux on the workpiece. Initially to start an arc, short circuit path is provided by introducing steel wool between the welding electrode and the workpiece. This is due to the coated flux material, when cold it is non-conductor of the electricity but in molten state, it is highly conductive. Welding zone is shielded by a blanket of flux, so that the arc is not visible. Hence, it is known as '*submerged arc welding*'. The arc so produced, melts the electrode, parent the metal and the coated flux, which forms a protective envelope around both the arc and the molten metal.

As the arc in progress, the melted electrode metal forms globules and mix up with the molten base metal, so that the weld is completed. In this welding, the electrode is completely covered by flux. The flux may be made of silica, metal oxides, and other compounds fused together and then crushed to proper size. Therefore, the welding takes place without spark, smoke, ash, etc. Thus, there is no need of providing protective shields, smoke collectors, and ventilating systems. Figure 5.18 shows the filling of parent metal by the submerged arc welding.

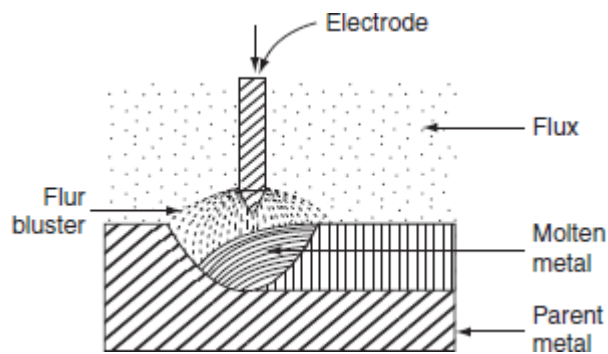

Fig. 5.18 Submerged arc welding

Voltage required for the submerged arc welding varies from 25 to 40 V. Current employed for welding depends upon the dimensions of the workpiece. Normally, if DC supply is used employing current ranging from 600 to 1,000 A, the current for AC is usually 2,000 A.

Advantages

- Deep penetration with high-quality weld is possible.
- Job with heavy thickness can be welded.
- The weld so obtained has good ductility, impact strength, high corrosion resistance, etc.
- The submerged arc welding can be done manually or automatically.

Applications

- The submerged arc welding is widely used in the heavy steel plant fabrication work.
- It can be employed for welding high strength steel, corrosion resistance steel, and low carbon steel.
- It is also used in the ship-building industry for splicing and fabricating subassemblies, manufacture of vessels, tanks, etc.

ELECTRON BEAM WELDING

It is one of the processes of the electric welding, in which the heat required for carrying out the welding operation is obtained by the electron bombardment heating.

In the electron bombardment heating, continuous stream of electron is produced between the electron emitting material cathode and the material to be heated. The electrons released from cathode possess KE traveling with high velocity in vacuum of 10^{-3} - 10^{-5} mmHg. When the fast moving electrons hit, the material or workpiece releases their KE as heat in the material to be heated. This heat is utilized to melt the metal.

If this process is carried out in high vacuum, without providing any electrodes, gasses, or filler metal, pure weld can be obtained. Moreover, high vacuum is maintained around the (filament) cathode. So that, it will not burn up and also produces continuous stable beam. If a vacuum was not used, the electron would strike the small partials in the atmosphere, reducing their velocity and also the heating ability. Thus, the operation should be performed in vacuum to present the reduction of the velocity of electron. That's why this is also called as '*vacuum electron beam welding*'. The power released by the electron beam is given by:

$$P = nqv \text{ watts,}$$

where n is the number of charged particles, q is the charge in coulombs per meter, and v is the voltage required to accelerate the electron from rest.

The electron beam welding (Fig. 5.19) process requires electron-emitting heating filament as cathode, focusing lens, etc.

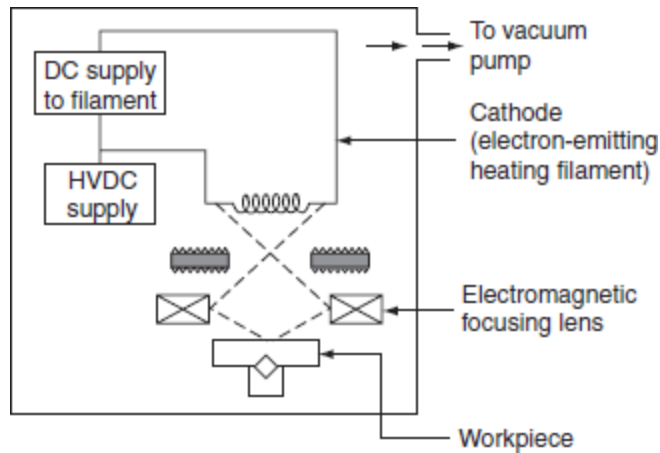

Fig. 5.19 Electron beam welding

Advantages

- Heat input to the electron beam welding can be easily controlled by varying beam current, voltage, the position of filament, etc.
- The electron beam welding can be used to join high temperature metals such as columbium.
- It can be employed for the welding of thick sections, due to high penetration to width ratio.
- It eliminates contamination of both weld zone and weld metal.
- Narrow electron beam reduces the distortion of workpiece.

Disadvantages

- The pressure build up in the vacuum chamber due to the vapor of parent metal causes electrical break down.
- Most of the super alloys, refractory metals, and combinations of dissimilar metals can also be welded.

LASER BEAM WELDING

The word laser means '*light amplification stimulated emission of radiation*'. It is the process of joining the metal pieces by focusing a monochromatic light into the extremely concentrated beams, onto the weld zone.

This process is used without shielding gas and without the application of pressure. The laser beam is very intense and unidirectional but can be focused and refracted in the same way as an ordinary light beam. The focus of the laser beam can be controlled by controlling the lenses, mirrors, and the distance to the workpiece. A block diagram of the laser beam welding system is shown in [Fig. 5.20](#).

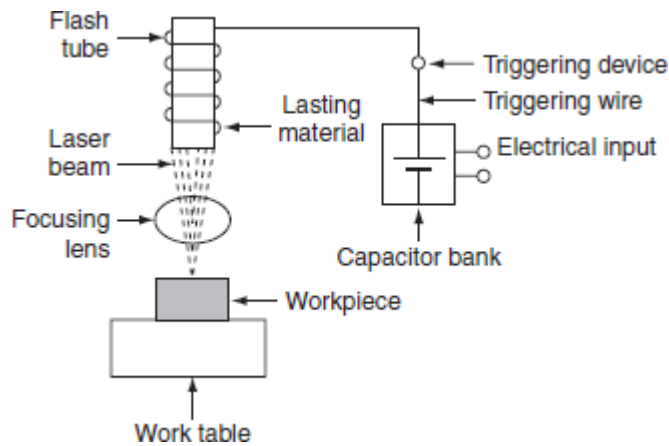

Fig. 5.20 Laser beam welding

In laser beam welding system, flash tube is designed to give thousands of flashes per second. When capacitor bank is triggered, the electrical energy is injected into the flash tube through trigger wire. Flash tube consists of thick xenon material, which produces high power levels for very short period. If the bulb is operated in this manner, it becomes an efficient device, which converts electrical energy to light energy. The laser is then activated.

The laser beam emitting from the flash tube, passing through the focusing lens, where it is pinpointed on the workpiece. The heat so developed by the laser beam melts the work-piece and the weld is completed. The welding characteristics of the laser are similar to the electron beam.

The laser beam has been used to weld carbon steel, low-alloy steel, aluminum, etc. The metals with relatively high-electrical resistance and the parts of different sizes and mass can be welded.

TYPES OF WELDING ELECTRODES

An electrode is a piece of metal in the form of wire or rod that is either bare or coated uniformly with flux. Electrode carries current for the welding operation. One contact end of the electrode must be clean and is inserted into the electrode holder, an arc is set up at the other end.

The electrodes used for the arc welding are classified as follows ([Fig. 5.21](#)).

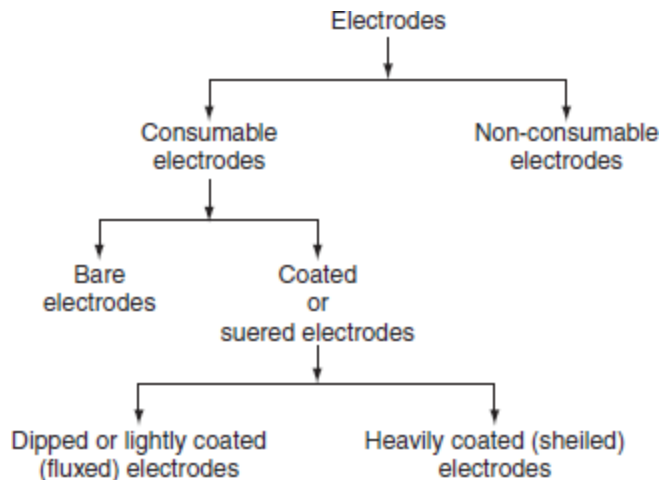

Fig Classification ofelectrods

Non-consumable electrodes

Electrodes, which do not consume or fuse during the welding process, are called non-consumable electrodes.

Ex: Electrodes made up of carbon, graphite, or tungsten do not consume during welding.

Consumable electrodes

Electrodes, which are consumed during the welding operation, are consumable electrodes. These are made up of various materials depending upon their purpose and the chemical composition of metal to be welded.

The consumable electrodes are made in the form of rod having diameter of about 2–8 mm and length of about 200–500 mm. They act as filler rod and are consumed during welding operation.

Bare electrodes

These are the consumable electrodes, which are not coated with any fluxing material. Bare electrodes are in the form of wire. During welding operation, an arc is struck between the workpiece and the electrode wire, then the electrode is melted down into the weld.

When the molten metal electrode and the workpiece are exposed to the atmosphere of oxygen and nitrogen, they form their oxides and nitrides and cause the formation of some non-metallic constituent, which reduces the strength and ductility of the deposited weld. The bare electrodes are usually employed in automatic and semiautomatic welding. With bare electrode, the welding

can be done satisfactorily with DC supply only if the electrode should be connected to the negative terminal of the supply.

Coated electrodes

Depending upon the thickness of flux coating, the coated electrode may be classified into:

1. lightly coated electrodes and
2. heavily coated electrodes.

For obtaining good weld, the coated electrodes are always preferred.

(i) Lightly coated electrodes

These electrodes are coated with thin layer of coating material up to less than 1 mm. This coating usually consists of lime mixed with soluble glass which serves as a binder. These electrodes are considered as improvement over bare electrodes.

The main purpose of using the light coating layer on the electrode is to increase the arc stability, so they are also called as stabilizing electrodes. The mechanical strength of the weld is increased because slag layer will not be formed on the molten weld. For this reason, lightly coated electrodes may only be used for welding non-essential workpieces.

(ii) Heavily coated electrodes

These electrodes have coating layer with heavy thickness. The heavily coated electrodes are sometimes referred to as the shielded arc electrodes. The materials commonly used for coating the electrodes are titanium oxide, ferromanganese, silica, flour, asbestos clay, calcium carbonate, etc. This electrode coating helps in improving the quality of weld, as if the coating layer of the electrodes burns in the heat of the arc provides gaseous shield around the arc, which prevents the formation of oxides and nitrides.

Advantages

- Arc is stabilized due to the flux compounds of sodium and potassium.
- The weld metal can be protected from the oxidizing action of oxygen and the nitrifying action of nitrogen due to the gas shielded envelope.
- The impurities present on the surface being welded are fluxed away.
- The electrode coating increases deposition efficiency and weld metal deposition rate through iron powder and ferro alloy addition.
- In case of AC supply arc cools at zero current and there is a tendency of deionizing the arc path. Covering gases keep the arc space ionized.
- The welding operation becomes faster due to the increased melting rate.
- The coated electrodes help to deoxidize and refine the weld metal.

The type of electrode used for the welding process depends upon the following factors.

- The nature of the electric supply, either AC or DC.
- The type of the metal to be welded.
- The welding position.
- The polarity of the welding machine.

COMPARISON BETWEEN RESISTANCE AND ARC WELDING

<i>Resistance welding</i>	<i>Arc welding</i>
1 The source of supply is AC only.	The source of supply is either AC (1- ϕ or 3- ϕ) or DC.
2 The heat developed is mainly due to the flow of contact resistance.	The heat developed is mainly due to the striking of arc between electrodes or an electrode and the workpiece.
3 The temperature attained by the workpiece is not so high.	The temperature of the arc is so high, so proper care should be taken during the welding.
4 External pressure is required.	No external pressure is required hence the welding equipment is more simple and easy to control.
5 Filler metal is not required to join two metal pieces.	Suitable filler electrodes are necessary to get proper welding strength.
6 It cannot be used for repair work; it is suitable for mass production.	It is not suitable for mass production. It is most suitable for repair works and where more metal is to be deposited.
7 The power consumption is low.	The power consumption is high.
8 The operating power factor is low.	The operating power factor is high.
9 Bar, roller, or flat type electrodes are used (not consumable).	Bare or coated electrodes are used (consumable or non-consumable).

ELECTRIC WELDING EQUIPMENT

Electric welding accessories required to carry out proper welding operation are:

1. Electric welding power sets.
2. Electrode holder to hold the electrodes.
3. Welding cable for connecting electrode and workpiece to the supply.
4. Face screen with colored glass.
5. Chipping hammers to remove slag from molten weld.

6. Wire brush to clean the weld.
7. Earth clamp and protective clothing.

COMPARISON BETWEEN AC AND DC WELDING

<i>AC welding</i>	<i>DC welding</i>
1 Motor generator set or rectifier is required in case of the availability of AC supply.	Only transformer is required.
2 The cost of the equipment is high.	The cost of the equipment is cheap.
3 Arc stability is more.	Arc stability is less.
4 The heat produced is uniform.	The heat produced is not uniform.
5 Both bare and coated electrodes can be used.	Only coated electrodes should be used.
6 The operating power factor is high.	The power factor is low. So, the capacitors are necessary to improve the power factor.
7 It is safer since no load voltage is low.	It is dangerous since no load voltage is high.
8 The electric energy consumption is 5–10 kWh/kg of deposited metal.	The electrical energy consumption is 3–4 kWh/kg of deposited metal
9 Arc blow occurs due to the presence of non-uniform magnetic field.	Arc blow will not occur due to the uniform magnetic field.
10 The efficiency is low due to the rotating parts.	The efficiency is high due to the absence of rotating parts.

UNIT 3

Illumination

INTRODUCTION

Study of illumination engineering is necessary not only to understand the principles of light control as applied to interior lighting design such as domestic and factory lighting but also to understand outdoor applications such as highway lighting and flood lighting. Nowadays, the electrically produced light is preferred to the other source of illumination because of an account of its cleanliness, ease of control, steady light output, low cost, and reliability. The best illumination is that it produces no strain on the eyes. Apart from its esthetic and decorative aspects, good lighting has a strictly utilitarian value in reducing the fatigue of the workers, protecting their health, increasing production, etc. The science of illumination engineering is therefore becoming of major importance.

Nature of light

Light is a form of electromagnetic energy radiated from a body and human eye is capable of receiving it. Light is a prime factor in the human life as all activities of human being ultimately depend upon the light.

Various forms of incandescent bodies are the sources of light and the light emitted by such bodies depends upon their temperature. A hot body about $500-800^{\circ}\text{C}$ becomes a red hot and about $2,500-3,000^{\circ}\text{C}$ the body becomes white hot. While the body is red-hot, the wavelength of the radiated energy will be sufficiently large and the energy available in the form of heat. Further, the temperature increases, the body changes from red-hot to white-hot state, the wavelength of the radiated energy becomes smaller and enters into the range of the wavelength of light. The wavelength of the light waves varying from 0.0004 to 0.00075 mm, i.e. $4,000-7,500 \text{ \AA}$ (1 Angstrom unit = 10^{-10} mm).

The eye discriminates between different wavelengths in this range by the sensation of color. The whole of the energy radiated out is not useful for illumination purpose. Radiations of very short wavelength varying from $0.0000156 \times 10^{-6}\text{m}$ to $0.001 \times 10^{-6}\text{m}$ are not in the visible range are called as rontgen or x-rays, which are having the property of penetrating through opaque bodies.

TERMS USED IN ILLUMINATION

The following terms are generally used in illumination.

Color: The energy radiation of the heated body is monochromatic, i.e. the radiation of only one wavelength emits specific color. The wavelength of visible light lies between

4,000 and 7,500 Å. The color of the radiation corresponding to the wavelength is shown in Fig. 6.1.

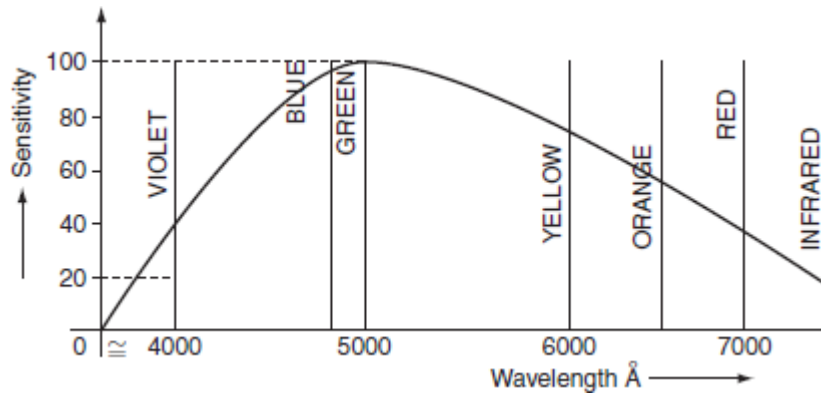

Fig. Wavelength

Relative sensitivity: The reacting power of the human eye to the light waves of different wavelengths varies from person to person, and also varies with age. The average relative sensitivity is shown in Fig. 6.2.

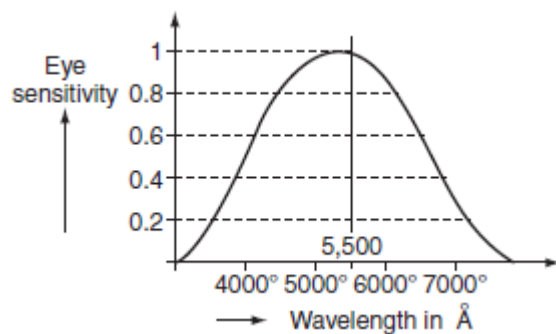

Fig. 6.2 The average relative sensitivity

The eye is most sensitive for a wavelength of 5,500 Å. So that, the relative sensitivity according to this wavelength is taken as unity.

Referred from Fig. 6.1, blue and violet corresponding to the short wavelengths and red to the long wavelengths, orange, yellow, and green being in the middle of the visible region of wavelength. The color corresponding to $5,500 \text{ \AA}$ is not suitable for most of the applications since yellowish green. The relative sensitivity at any particular wavelength (λ) is known as relative luminous factor (K_λ).

Light: It is defined as the radiant energy from a hot body that produces the visual sensation upon the human eye. It is expressed in lumen-hours and it analogous to watt-hours, which denoted by the symbol 'Q'.

Luminous flux: It is defined as the energy in the form of light waves radiated per second from a luminous body. It is represented by the symbol ' ϕ ' and measured in lumens.

Ex: Suppose the luminous body is an incandescent lamp.

The total electrical power input to the lamp is not converted to luminous flux, some of the power lost through conduction, convection, and radiation, etc. A fraction of the remaining radiant flux is in the form of light waves lies in between the visual range of wavelength, i.e. between $4,000$ and $7,000 \text{ \AA}$, as shown in Fig. 6.3.

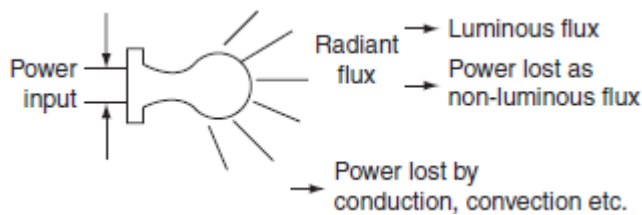

Fig. Flux diagram

Radiant efficiency

When an electric current is passed through a conductor, some heat is produced to I^2R loss, which increases its temperature of the conductor. At low temperature, conductor radiates energy in the form of heat waves, but at very high temperatures, radiated energy will be in the form of light as well as heat waves.

'Radiant efficiency is defined as the ratio of energy radiated in the form of light, produces sensation of vision to the total energy radiated out by the luminous body'.

$$\text{Radiant efficiency} = \frac{\text{energy radiated in the form of light}}{\text{total energy radiated by the body}}.$$

Plane angle

A plane angle is the angle subtended at a point in a plane by two converging lines (Fig. 6.4). It is denoted by the Greek letter ' θ ' (theta) and is usually measured in degrees or radians.

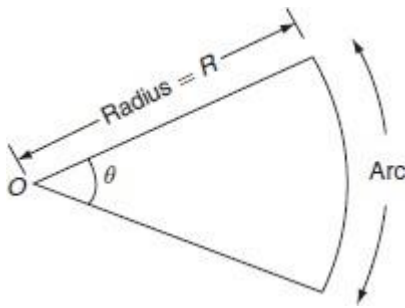

Fig. 6.4 Plane angle

$$\therefore \text{Plane angle } (\theta) = \frac{\text{arc}}{\text{radius}}. \quad (6.1)$$

One radian is defined as the angle subtended by an arc of a circle whose length is equal to the radius of the circle.

Solid angle

Solid angle is the angle subtended at a point in space by an area, i.e., the angle enclosed in the volume formed by numerous lines lying on the surface and meeting at the point (Fig. 6.5). It is usually denoted by symbol ' ω ' and is measured in steradian.

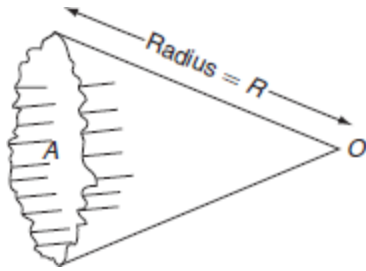

Fig. Solid angle

$$\therefore \text{Solid angle } (\omega) = \frac{\text{area}}{\text{radius}^2}. \quad (6.2)$$

The largest solid angle subtended at the center of a sphere:

$$\omega = \frac{\text{area of sphere}}{\text{radius}^2} = \frac{4\pi r^2}{R^2} = 4\pi \text{ steradians.}$$

Relationship between plane angle and solid angle

Let us consider a curved surface of a spherical segment ABC of height 'h' and radius of the sphere 'r' as shown in Fig. 6.6. The surface area of the curved surface of the spherical segment $ABC = 2\pi rh$. From the Fig. 6.6:

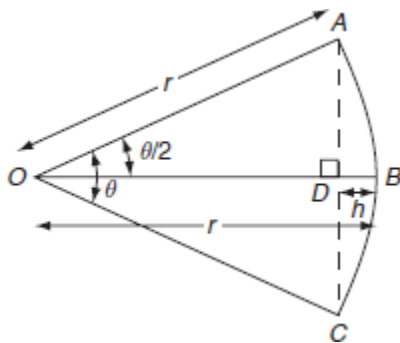

Fig. Sectional view for solid angle

$$BD = OB - OD$$

$$\begin{aligned} h &= r - r \cos\left(\frac{\theta}{2}\right) \quad [\because \text{From } \triangle ODA, OD = r \cos \theta/2] \\ &= r \left(1 - \cos \frac{\theta}{2}\right). \end{aligned}$$

$$\begin{aligned} \therefore \text{The surface area of the segment} &= 2\pi r h \\ &= 2\pi r^2 \left[1 - \cos \frac{\theta}{2}\right]. \end{aligned}$$

$$\begin{aligned} \text{We know solid angle } (\omega) &= \frac{\text{area}}{(\text{radius})^2} \\ &= \frac{2\pi r^2 \left(1 - \cos \frac{\theta}{2}\right)}{r^2} \\ &= 2\pi \left(1 - \cos \frac{\theta}{2}\right). \quad (6.3) \end{aligned}$$

From the Equation (6.3), the curve shows the variation of solid angle with plane angle is shown in Fig. 6.7.

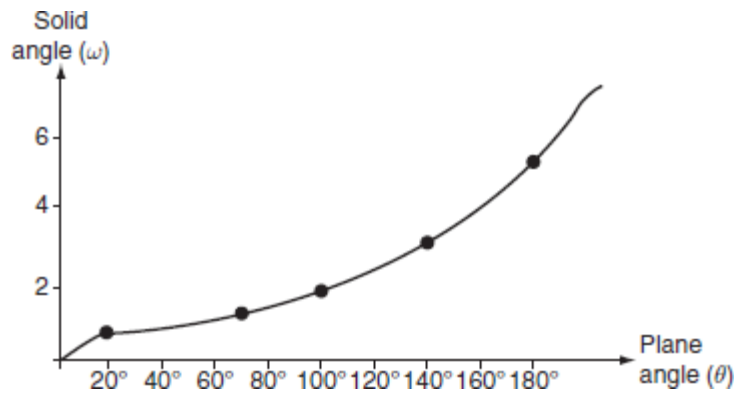

Fig. 6.7 Relation between solid angle and plane angle

Luminous intensity

Luminous intensity in a given direction is defined as the luminous flux emitted by the source per unit solid angle (Fig. 6.8).

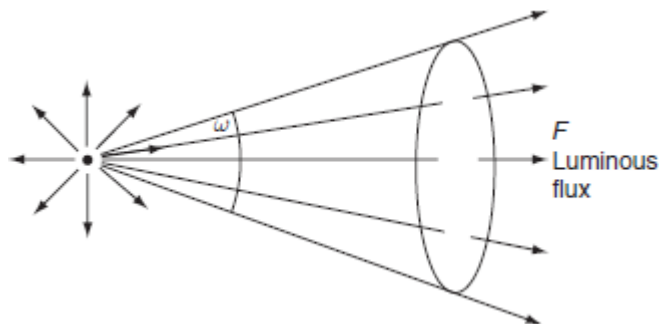

Fig. 6.8 Luminous flux emitting from the source

It is denoted by the symbol ' I ' and is usually measured in 'candela'.

Let ' F ' be the luminous flux crossing a spherical segment of solid angle ' ω '. Then

luminous intensity $(I) = \frac{\phi}{\omega}$ lumen/steradian or candela.

Lumen: It is the unit of luminous flux.

It is defined as the luminous flux emitted by a source of one candle power per unit solid angle in all directions.

Lumen = candle power of source \times solid angle.

$$\text{Lumen} = \text{CP} \times \omega$$

Total flux emitted by a source of one candle power is 4π lumens.

Candle power (CP)

The CP of a source is defined as the total luminous flux lines emitted by that source in a unit solid angle.

$$\text{CP} = \frac{\text{lumen}}{\omega} \text{ lumen/steradian or candela.}$$

Illumination

Illumination is defined as the luminous flux received by the surface per unit area.

It is usually denoted by the symbol ' E ' and is measured in lux or lumen/m² or meter candle or foot candle.

$$\begin{aligned} \text{Illumination, } E &= \frac{\text{luminous flux}}{\text{area}} \\ &= \frac{\phi}{A} = \frac{\text{CP} \times \omega}{A} \text{ lux.} \end{aligned}$$

Lux or meter candle

It is defined as the illumination of the inside of a sphere of radius 1 m and a source of 1 CP is fitted at the center of sphere.

Foot candle

It is the unit of illumination and is defined as the illumination of the inside of a sphere of radius 1 foot, and a source of 1 CP is fitted at the center of it.

We know that 1 lux = 1 foot candle = 1 lumen/(ft)²

$$1 \text{ foot candle} = \frac{\text{lumen}}{\left(\frac{1}{3.28}\right)^2 \text{ m}^2} = 10.76 \text{ lux or m-candle}$$

∴ 1 foot candle = 10.76 lux.

Brightness

Brightness of any surface is defined as the luminous intensity per unit surface area of the projected surface in the given direction. It is usually denoted by symbol 'L'.

If the luminous intensity of source be 'I' candela on an *area A*, then the projected area is $A \cos \theta$.

$$\therefore \text{Brightness, } L = \frac{I}{A \cos \theta}$$

The unit of brightness is candela/m² or candela/cm² or candela/(ft)².

Relation between I, E, and L

Let us consider a uniform diffuse sphere with radius *r* meters, at the center a source of 1 CP, and luminous intensity *I* candela.

$$\therefore \text{Brightness } (L) = \frac{I}{\pi r^2}$$

$$\begin{aligned} \text{and Illumination } (E) &= \frac{\phi}{A} = \frac{CP \times \omega}{A} \\ &= \frac{I}{4 \pi r^2} \times 4\pi = \frac{I}{r^2} \end{aligned}$$

$$\therefore E = \frac{I}{r^2} = \frac{I}{\pi r^2} \times \pi = \pi L$$

$$\therefore E = \pi L = \frac{I}{r^2}. \quad (6.4)$$

Mean horizontal candle power (MHCP)

MHCP is defined as the mean of the candle power of source in all directions in horizontal plane.

Mean spherical candle power (MSCP)

MSCP is defined as the mean of the candle power of source in all directions in all planes.

Mean hemispherical candle power (MHSCP)

MHSCP is defined as the mean of the candle power of source in all directions above or below the horizontal plane.

Reduction factor

Reduction factor of the source of light is defined as the ratio of its mean spherical candle power to its mean horizontal candle power.

$$\text{i.e., reduction factor} = \frac{MSCP}{MHCP}.$$

Lamp efficiency

It is defined as the ratio of the total luminous flux emitting from the source to its electrical power input in watts.

$$\therefore \text{Lamp efficiency} = \frac{\text{luminous flux}}{\text{power input}}.$$

It is expressed in lumen/W.

Specific consumption

It is defined as the ratio of electric power input to its average candle power.

Space to height ratio

It is defined as ratio of horizontal distance between adjacent lamps to the height of their mountings.

$$\text{Space to height ratio} = \frac{\text{horizontal distance between two adjacent lamps}}{\text{mounting height of lamps above the working plane}}.$$

Coefficient of utilization or utilization factor

It is defined as the ratio of total number of lumens reaching the working plane to the total number of lumens emitting from source.

$$\text{Utilization factor} = \frac{\text{total lumens reaching the working plane}}{\text{total lumens emitting from source}}.$$

Maintenance factor

It is defined as the ratio of illumination under normal working conditions to the illumination when everything is clean.

$$\text{Maintenance factor} = \frac{\text{illumination under normal working condition}}{\text{illumination under every thing is clean}}.$$

Its value is always less than 1, and it will be around 0.8. This is due to the accumulation of dust, dirt, and smoke on the lamps that emit less light than that they emit when they are so clean. Frequent cleaning of lamp will improve the maintenance factor.

Depreciation factor

It is defined as the ratio of initial illumination to the ultimate maintained illumination on the working plane.

$$\therefore \text{Depreciation factor} = \frac{1}{\text{maintenance factor}}.$$

Its values is always more than 1.

Waste light factor

When a surface is illuminated by several numbers of the sources of light, there is certain amount of wastage due to overlapping of light waves; the wastage of light is taken into account depending upon the type of area to be illuminated. Its value for rectangular area is 1.2 and for irregular area is 1.5 and objects such as statues, monuments, etc.

Absorption factor

Normally, when the atmosphere is full of smoke and fumes, there is a possibility of absorption of light. Hence, the total lumens available after absorption to the total lumens emitted by the lamp are known as absorption factor.

$$\text{Absorption factor} = \frac{\text{the total lumens available after absorption}}{\text{the total lumens given out by the lamp}}$$

Reflection factor or coefficient of reflection

When light rays impinge on a surface, it is reflected from the surface at an angle of incidence shown in Fig. 6.9. A portion of incident light is absorbed by the surface.

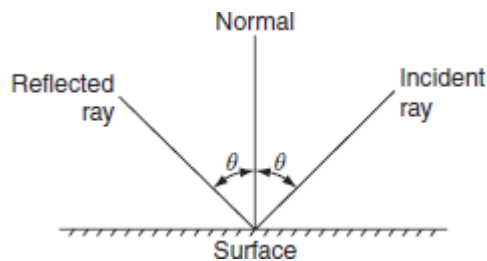

Fig. Reflected ray

The ratio of luminous flux leaving the surface to the luminous flux incident on it is known as reflection factor.

$$\text{Reflection factor} = \frac{\text{reflected light}}{\text{incident light}}$$

Its value will be always less than 1.

Beam factor

It is defined as the ratio of 'lumens in the beam of a projector to the lumens given out by lamps'. Its value is usually varies from 0.3 to 0.6. This factor is taken into account for the absorption of light by reflector and front glass of the projector lamp.

Example 6.1: A 200-V lamp takes a current of 1.2 A, it produces a total flux of 2,860 lumens. Calculate:

1. the MSCP of the lamp and
2. the efficiency of the lamp.

Solution:

Given $V = 200 \text{ V}$

$I = 1.2 \text{ A}$, flux = 2,860 lumens.

$$(i) \text{ MSCP} = \frac{\text{total flux}}{4\pi} = \frac{2860}{4\pi} = 227.59.$$

Example 6.2: A room with an area of $6 \times 9 \text{ m}$ is illustrated by ten 80-W lamps. The luminous efficiency of the lamp is 80 lumens/W and the coefficient of utilization is 0.65. Find the average illumination.

Solution:

Room area = $6 \times 9 = 54 \text{ m}^2$.

Total wattage = $80 \times 10 = 800 \text{ W}$.

Total flux emitted by ten lamps = $80 \times 800 = 64,000 \text{ lumens}$.

Flux reaching the working plane = $64,000 \times 0.65 = 41,600 \text{ lumens}$.

$$\therefore \text{ Illumination, } E = \frac{\phi}{A} = \frac{41,600}{54} = 770.37 \text{ lux.}$$

Example 6.3: The luminous intensity of a lamp is 600 CP. Find the flux given out. Also find the flux in the hemisphere containing the source of light and zero above the horizontal.

Solution:

Flux emitted by source (lumen)

= Intensity (I) \times solid angle (ω)

= $600 \times 2\pi = 3,769.911$ lumens

\therefore Flux emitted in the lower hemisphere = 3,769.911 lumens.

Example 6.4: The flux emitted by 100-W lamp is 1,400 lumens placed in a frosted globe of 40 cm diameter and gives uniform brightness of 250 milli-lumens/m² in all directions. Calculate the candela power of the globe and the percentage of light absorbed by the globe.

Solution:

Flux emitted by the globe

= brightness \times globe area

$$= \left[\frac{250}{1,000} \right] \times \left[4\pi \left(\frac{40}{2} \right)^2 \right]$$

= 1,256.63 lumens

Flux absorbed by the globe

= flux emitted by source – flux emitted by globe

= $1,400 - 1,256.63$

= 143.36 lumens.

\therefore The percentage of light absorbed by the globe = $\frac{143.36}{1,400} \times 100 = 10.24\%$.

Example 6.5: A surface inclined at an angle 40° to the rays is kept 6 m away from 150 candle power lamp. Find the average intensity of illumination on the surface.

Solution:

From the Fig. P.6.1:

$$\theta = (90^\circ - 40^\circ) = 50^\circ.$$

\therefore Average illumination:

$$\begin{aligned} E &= \frac{I}{d^2} \times \cos \theta \\ &= \frac{150}{(4)^2} \times \cos 50^\circ \\ &= 6.026 \text{ lux.} \end{aligned}$$

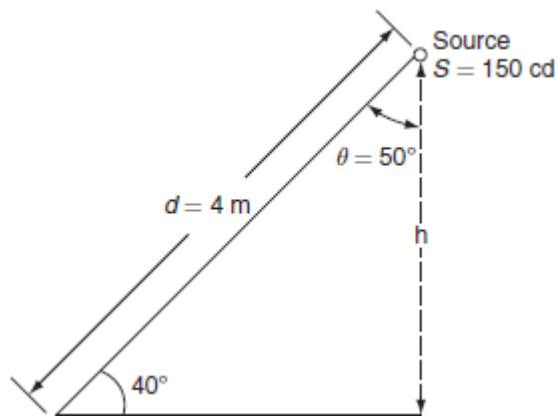

Fig. P.6.1

LAWS OF ILLUMINATION

Mainly there are two laws of illumination.

1. Inverse square law.

2. Lambert's cosine law.

Inverse square law

This law states that 'the illumination of a surface is inversely proportional to the square of distance between the surface and a point source'.

Proof:

Let, 'S' be a point source of luminous intensity 'I' candela, the luminous flux emitting from source crossing the three parallel plates having areas $A_1, A_2,$ and A_3 square meters, which are separated by a distances of $d, 2d,$ and $3d$ from the point source respectively as shown in Fig. 6.10.

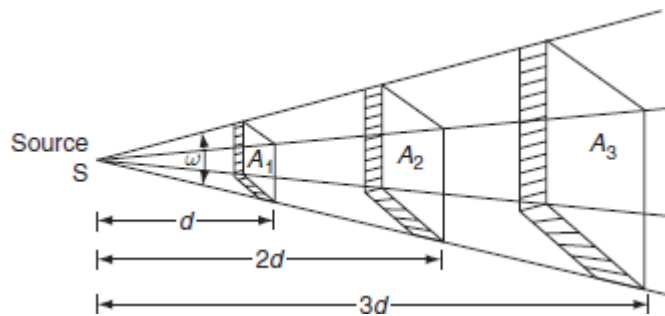

Fig. 6.10 Inverse square law

For area A_1 , solid angle $\omega = \frac{A_1}{d^2}$.

Luminous flux reaching the area $A_1 =$ luminous intensity \times solid angle

$$= I \times \omega = I \times \frac{A_1}{d^2}.$$

\therefore Illumination ' E_1 ' on the surface area ' A_1 ' is:

$$E_1 = \frac{\text{flux}}{\text{area}} = \frac{IA_1}{d^2} \times \frac{1}{A_1}$$

$$\therefore E_1 = \frac{I}{d^2} \text{ lux.} \quad (6.5)$$

Similarly, illumination ' E_2 ' on the surface *area* A_2 is:

$$E_2 = \frac{I}{(2d)^2} \text{ lux} \quad (6.6)$$

and illumination ' E_3 ' on the surface area A_3 is:

$$E_3 = \frac{I}{(3d)^2} \text{ lux.} \quad (6.7)$$

From Equations (6.5), (6.6), and (6.7)

$$E_1 : E_2 : E_3 = \frac{1}{d^2} : \frac{1}{(2d)^2} : \frac{1}{(3d)^2}. \quad (6.8)$$

Hence, from Equation (6.8), illumination on any surface is inversely proportional to the square of distance between the surface and the source.

Lambert's cosine law

This law states that 'illumination, E at any point on a surface is directly proportional to the cosine of the angle between the normal at that point and the line of flux'.

Proof:

While discussing, the Lambert's cosine law, let us assume that the surface is inclined at an angle ' θ ' to the lines of flux as shown in Fig. 6.11.

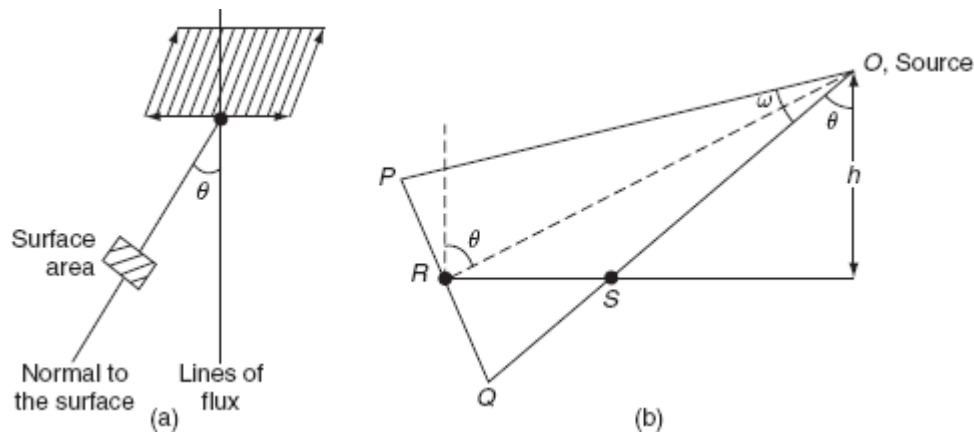

Fig. 6.11 Lambert's cosine law

Let

$PQ =$ The surface area normal to the source and inclined at ' θ ' to the vertical axis.

$RS =$ The surface area normal to the vertical axis and inclined at an angle θ to the source 'O'.

Therefore, from Fig. 6.11:

$$PQ = RS \cos \theta.$$

$$\therefore \text{The illumination of the surface } PQ, E_{PQ} = \frac{\text{flux}}{\text{area of } PQ}$$

$$= \frac{I \times \omega}{\text{area of } PQ} = \frac{I}{\text{area of } PQ} \times \frac{\text{area of } PQ}{d^2} \quad [\because \omega = \text{area}/(\text{radius})^2]$$

$$= \frac{I}{d^2}.$$

(6.9)

$$\begin{aligned} \therefore \text{The illumination of the surface } RS, E_{RS} &= \frac{\text{flux}}{\text{area of } RS} = \frac{\text{flux}}{\text{area of } PQ / \cos \theta} \\ & \quad [\because PQ = RS \cos \theta] \\ &= \frac{I}{d^2} \cos \theta. \quad (6.10) \end{aligned}$$

From Fig. 6.11(b):

$$\begin{aligned} \cos \theta &= \frac{h}{d} \\ \text{or } d &= \frac{h}{\cos \theta}. \end{aligned}$$

Substituting 'd' from the above equation in Equation (6.10):

$$\therefore E_{RS} = \frac{I}{(h/\cos \theta)^2} \times \cos \theta = \frac{I}{h^2} \cos^3 \theta \quad (6.11)$$

$$\therefore E_{RS} = \frac{I}{d^2} \cos \theta = \frac{I}{h^2} \cos^3 \theta \quad (6.12)$$

where d is the distance between the source and the surface in m, h is the height of source from the surface in m, and I is the luminous intensity in candela.

Hence, Equation (6.11) is also known as 'cosine cube' law. This law states that the 'illumination at any point on a surface is dependent on the cube of cosine of the angle between line of flux and normal at that point'.

Note:

*From the above laws of illumination, it is to be noted that inverse square law is only applicable for the surfaces if the surface is normal to the line of flux. And Lambert's cosine law is applicable for the surfaces if the surface is inclined an angle ' θ ' to the line of flux.

Example 6.6: The illumination at a point on a working plane directly below the lamp is to be 60 lumens/m². The lamp gives 130 CP uniformly below the horizontal plane. Determine:

1. The height at which lamp is suspended.
2. The illumination at a point on the working plane 2.8 m away from the vertical axis of the lamp.

Solution:

Given data:

Candle power of the lamp = 130 CP.

The illumination just below the lamp, $E = 60$ lumen/m².

1. From the Fig. P.6.2, the illumination just below the lamp, i.e., at point A:

$$E_A = \frac{I}{h^2}$$

$$\therefore h = \sqrt{\frac{I}{E_A}} = \sqrt{\frac{130}{60}} = 1.471 \text{ m.}$$

2. The illumination at point 'B':

$$E_B = \frac{I}{h^2} \cos^3 \theta$$

$$= \frac{130}{(2.8)^2} \left\{ \frac{2.8}{\sqrt{2.8^2 + 1.471^2}} \right\}^3 = 11.504 \text{ lux.}$$

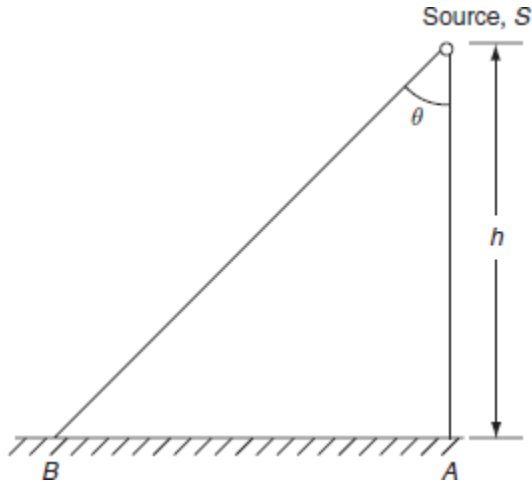

Fig. P.6.2

Example 6.7: A lamp having a candle power of 300 in all directions is provided with a reflector that directs 70% of total light uniformly on a circular area 40-m diameter. The lamp is hung at 15 m above the area.

1. Calculate the illumination.
2. Also calculate the illumination at the center.
3. The illumination at the edge of the surface without reflector.

Solution:

Given data:

Candle power of the lamp = 300 CP.

Circular area diameter (D) = 40 m.

Height of mounting = 15 m.

1. The illumination on the circular area (Fig. P.6.3):

$$E = \frac{\text{flux}}{\text{area}} = \frac{CP \times \omega}{A}$$

$$\text{Here, } A = \frac{\pi}{4} D^2 = \frac{\pi}{4} \times 40^2 = 400 \pi \text{ m}^2.$$

$$\begin{aligned} \text{Solid angle } \omega &= 2\pi (1 - \cos\theta) \\ &= 2\pi \left(1 - \frac{15}{\sqrt{15^2 + 20^2}} \right) \\ &= 0.8 \pi \text{ steradians.} \end{aligned}$$

$$\begin{aligned} \therefore \text{Illumination } E &= \frac{\text{flux}}{\text{area}} = \frac{CP \times \omega}{A} \\ &= \frac{300 \times 0.8\pi}{400\pi} \\ &= 0.6 \text{ lux.} \end{aligned}$$

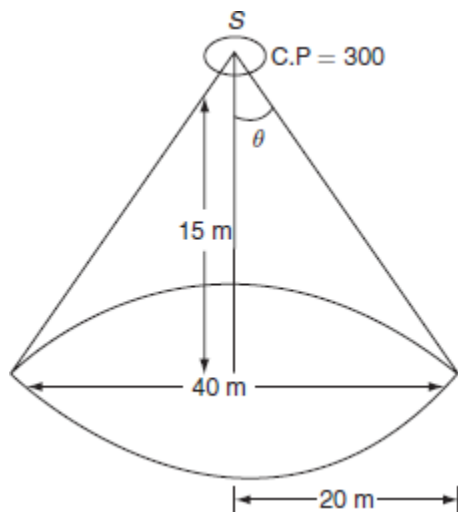

Fig. P.6.3

2. The illumination at the center with reflector 70%:

$$= \frac{\phi}{A} \times 0.7 = \frac{CP \times \omega}{A} \times 0.7$$

$$= \frac{300 \times 4\pi}{400\pi} \times 0.7$$

$$= 2.1 \text{ lux.}$$

3. The illumination at the edge without reflector:

$$\begin{aligned} &= \frac{CP}{d^2} \times \cos\theta \\ &= \frac{300}{(\sqrt{15^2 + 10^2})^2} \times \frac{15}{\sqrt{15^2 + 10^2}} \\ &= 0.768 \text{ lux.} \end{aligned}$$

Example 6.8: The luminous intensity of a source is 600 candela is placed in the middle of a $10 \times 6 \times 2$ m room. Calculate the illumination:

1. At each corner of the room.
2. At the middle of the 6-m wall.

Solution:

Given data:

Luminous intensity, (I) = 600 cd.

Room area = $10 \times 6 \times 2$ m.

1. From the Fig. P.6.4:

$$OB = BD = \frac{\sqrt{10^2 + 6^2}}{2} = 5.83 \text{ m}$$

$$BS = d = \sqrt{2^2 + (5.38)^2} = 6.163 \text{ m.}$$

\therefore The illumination at the corner 'B':

$$E_B = E_A = E_C = E_D$$

$$\begin{aligned} \frac{I}{d^2} \cos\theta &= \frac{600}{(6.163)^2} \times \frac{2}{(6.163)} \\ &= 5.126 \text{ lux.} \end{aligned}$$

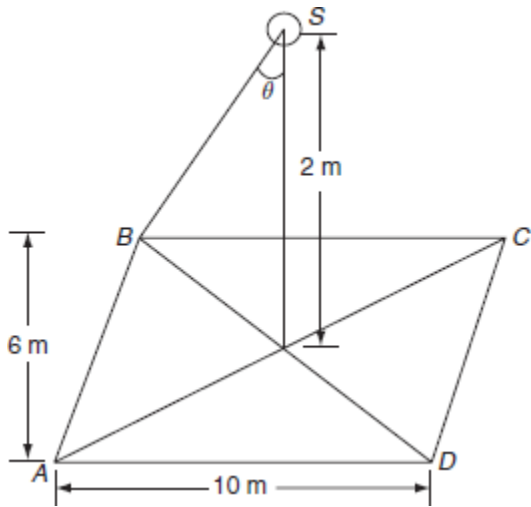

Fig. P.6.4

2. From Fig. P.6.5:

$$PS = \sqrt{2^2 + 5^2}$$

$$= 5.385 \text{ m.}$$

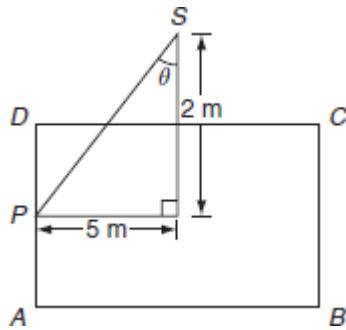

Fig. P.6.5

The illumination at the point 'P', $E_p = \frac{I}{d^2} \cos\theta$

$$= \frac{600}{(5.385)^2} \times \frac{2}{(5.385)}$$

$$= 7.684 \text{ lux.}$$

Example 6.9: The candle power of a source is 200 candela in all directions below the lamp. The mounting height of the lamp is 6 m. Find the illumination:

1. Just below the lamp.
2. 3 m horizontally away from the lamp on the ground.
3. The total luminous flux in an area of 1.5-m diameter around the lamp on the ground.

Solution:

The candle power of the source, $I = 200$ candela.

Mounting height (h) = 6 m.

1. The illumination just below the lamp, i.e., at point 'A':

$$E_p = \frac{I}{d^2} \cos\theta$$

$$= \frac{600}{(5.385)^2} \times \frac{2}{(5.385)}$$

$$= 7.684 \text{ lux.}$$

2. From Fig. P.6.6:

$$d = \sqrt{3^2 + 6^2} = 6.708.$$

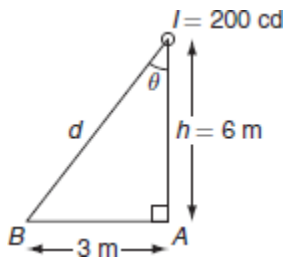

Fig. P.6.6

The illumination 3 m away from the lamp on the ground, i.e., at point 'B' (Fig. P.6.7):

$$E_B = \frac{I}{d^2} \cos\theta$$

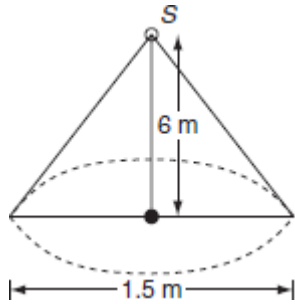

Fig. P.6.7

$$= \frac{200}{(6.708)^2} \times \frac{6}{(6.708)}$$

$$= 3.975 \text{ lux.}$$

3.

$$\text{Surface area} = \frac{\pi}{4} d^2$$

$$= \frac{\pi}{4} \times (1.5)^2$$

$$= 1.767 \text{ m}^2.$$

The total flux reaching the area around the lamp:

$$= E_A \times \text{surface area}$$

$$= 5.55 \times 1.767$$

$$= 9.80 \text{ lumens.}$$

Example 6.10: Two sources of candle power or luminous intensity 200 candela and 250 candela are mounted at 8 and 10 m, respectively. The horizontal distance between the lamp posts is 40 m, calculate the illumination in the middle of the posts.

Solution:

From Fig. P.6.8:

$$\begin{aligned}d_1 &= \sqrt{8^2 + 20^2} \\ &= 21.54.\end{aligned}$$

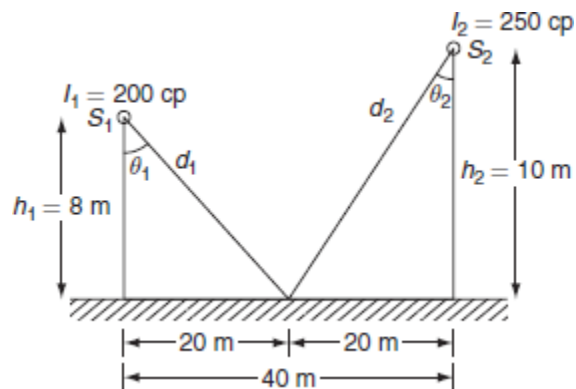
**Fig. P.6.8**

$$\begin{aligned}\cos\theta_1 &= \frac{h_1}{d_1} = \frac{8}{21.54} \\ &= 0.37.\end{aligned}$$

$$\begin{aligned}\therefore \text{The illumination at the point 'P' due to the source 'S}_1\text{' } &= \frac{I_1}{d_1^2} \cos\theta_1 \\ E_1 &= \frac{200}{(21.54)^2} \times 0.37 \\ &= 0.159 \text{ lux.}\end{aligned}$$

$$\text{and } d_2 = \sqrt{10^2 + 20^2} = 22.36$$

$$\cos\theta_2 = \frac{h_2}{d_2} = \frac{10}{22.36} = 0.447.$$

The illumination at the point 'P' due to the source 'S₂':

$$\begin{aligned} E_2 &= \frac{I_2}{d_2^2} \times \cos\theta_2 \\ &= \frac{250}{(22.36)^2} \times 0.447 = 0.2235 \text{ lux.} \end{aligned}$$

∴ The total illumination at 'P' due to both the sources S₁ and S₂ = E₁ + E₂

$$= 0.159 + 0.2235$$

$$= 0.3825 \text{ lux.}$$

Example 6.11: Two sources of having luminous intensity 400 candela are hung at a height of 10 m. The distance between the two lamp posts is 20 m. Find the illumination (i) beneath the lamp and (ii) in the middle of the posts.

Solution:

Given data:

Luminous intensity = 400 CP.

Mounting height = 10 m.

Distance between the lamp posts = 20 m.

1. From Fig. P.6.9:

$$d_1 = \sqrt{10^2 + 20^2} = 22.36.$$

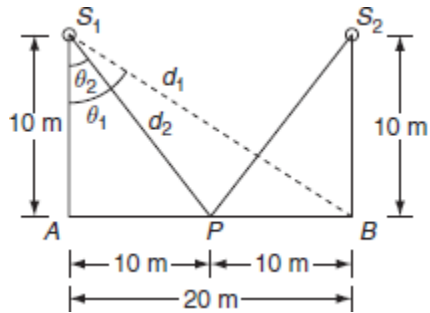

Fig. P.6.9

$$\cos\theta_1 = \frac{h}{d_1} = \frac{10}{22.36} = 0.4472.$$

The illumination at 'B' due to 'S₁':

$$\begin{aligned} E_1 &= \frac{I}{d_1^2} \cos\theta_1 \\ &= \frac{400}{(22.36)^2} \times 0.4472 \\ &= 0.35778 \text{ lux.} \end{aligned}$$

The illumination at 'B' due to 'S₂':

$$E_2 = \frac{400}{10^2} = 4 \text{ lux.}$$

$$\begin{aligned} \therefore \text{The total illumination at 'B'} &= E_1 + E_2 \\ &= 0.3577 + 4 \\ &= 4.3577 \text{ lux.} \end{aligned}$$

$$d_2 = \sqrt{10^2 + 10^2} = 14.14.$$

$$\cos\theta_2 = \frac{10}{14.14} = 0.707.$$

The illumination at 'P' due to S₁ is:

$$E_1 = \frac{I}{d_2^2} \times \cos\theta_2$$

$$= \frac{400}{(14.14)^2} \times 0.707 = 1.414 \text{ lux.}$$

The illumination at 'P' due to S_2 , ' E_2 ' will be same as E_1

$$\begin{aligned} \therefore \text{The illumination at 'P' due to both } S_1 \text{ and } S_2: \\ &= E_1 + E_2 = E_1 + E_1 \\ &= 2E_1 = 2 \times 1.414 \\ &= 2.828 \text{ lux.} \end{aligned}$$

Example 6.12: In a street lighting, two lamps are having luminous intensity of 300 candela, which are mounted at a height of 6 and 10 m. The distance between lamp posts is 12 m. Find the illumination, just below the two lamps.

Solution:

1. The illumination at 'B' = the illumination due to L_1 + the illumination due to L_2 . Form Fig. P.6.10:

$$d_1 = \sqrt{6^2 + 12^2} = 13.416 \text{ m.}$$

$$\cos\theta_1 = \frac{h_1}{d_1} = \frac{6}{13.416} = 0.447.$$

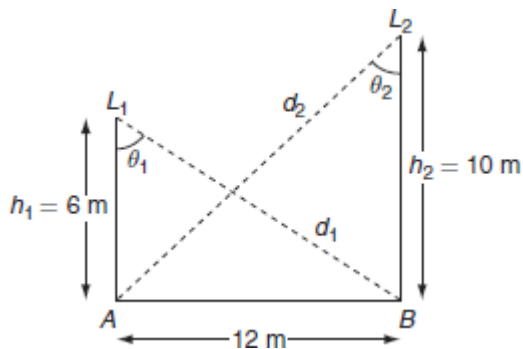

Fig. P.6.10

$$\begin{aligned} \therefore \text{The illumination at 'B' due to } L_1 &= \frac{I}{d_1^2} \cos\theta_1 \\ &= \frac{300}{(13.416)^2} \times 0.447 \\ &= 0.745 \text{ lux.} \end{aligned}$$

$$\begin{aligned} \text{Illumination at 'B' due to } L_2 &= \frac{I}{h_2^2} \\ &= \frac{300}{10^2} \\ &= 3 \text{ lux.} \end{aligned}$$

\therefore The total illumination at 'B' due to the two lamps = 0.745 + 3 = 3.745 lux.

2. The illumination at 'A' = the illumination due to L_1 + the illumination due to L_2 .

$$d_2 = \sqrt{10^2 + 12^2} = 15.62 \text{ m.}$$

$$\cos\theta_2 = \frac{h_2}{d_2} = \frac{10}{15.62} = 0.64.$$

$$\begin{aligned} \therefore \text{The illumination at 'A' due to lamp } L_1 &= \frac{I}{d_2^2} \cos\theta_2 \\ &= \frac{300}{(15.62)^2} \times 0.64 \\ &= 0.786 \text{ lux.} \end{aligned}$$

$$\begin{aligned} \text{Illumination at A due to lamp 'L}_2\text{' } &= \frac{I}{h_1^2} \\ &= \frac{300}{6^2} \\ &= 8.33 \text{ lux.} \end{aligned}$$

\therefore The total illumination at 'A' due to both lamps = 0.786 + 8.33 = 9.116 lux.

Example 6.13: Four lamps 15 m apart are arranged to illuminate a corridor. Each lamp is suspended at a height of 8 m above the floor level. Each lamp gives 450 CP in all directions below the horizontal; find the illumination at the second and the third lamp.

Solution:

Given data:

Luminous intensity = 450 CP.

Mounting height = 8 m.

Distance between the adjacent lamps = 15 m (Fig. P.6.11).

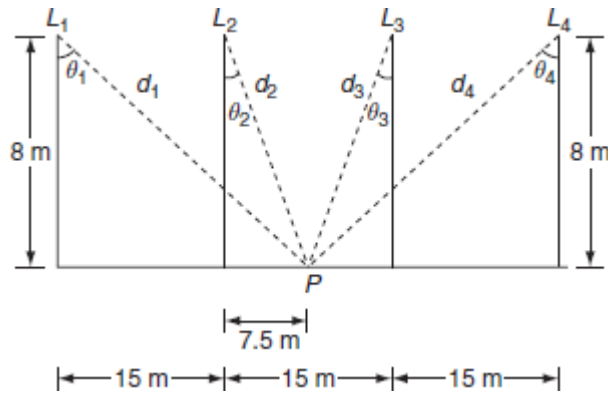

Fig. P.6.11

The illumination at 'P' = the illumination due to L_1 + the illumination due to L_2
+ the illumination due to L_3 + the illumination due to L_4 .

The illumination at 'P' due to L_1 , $E_1 = \frac{I}{d_1^2} \cos\theta_1$.

But, $d_1 = \sqrt{8^2 + 15^2} = 17$.

$\cos\theta_1 = \frac{h}{d_1} = \frac{8}{17} = 0.470$.

$$\begin{aligned}\therefore E_1 &= \frac{I}{d_1^2} \cos\theta_1 \\ &= \frac{450}{(17)^2} \times 0.47 \\ &= 0.73 \text{ lux.}\end{aligned}$$

The illumination at 'P' due to lamp ' L_2 ' is:

$$\begin{aligned}
 E_2 &= \frac{I}{d_2^2} \cos \theta_2 \\
 &= \frac{450}{\left[\sqrt{8^2 + (7.5)^2} \right]^2} \times \frac{8}{\sqrt{8^2 + 7.5^2}} \\
 &= 2.73 \text{ lux.}
 \end{aligned}$$

Similarly, the illumination at 'P' due to the lamp L_3 'E₃' = the illumination at 'P' due to the

lamp 'L₂', 'E₂',

and the illumination at 'P' due to the lamp L_4 , 'E₄' = illumination at 'P' due to the lamp

'L₁', 'E₁'.

∴ The total illumination at 'P' = $E_1 + E_2 + E_3 + E_4$

$$= 2E_1 + 2E_2$$

$$= 2(E_1 + E_2)$$

$$= 2(0.73 + 2.73)$$

$$= 6.92 \text{ lux.}$$

Example 6.15: Two lamps of each 500 CP are suspended 10 m from the ground and are separated by a distance of 20 m apart. Find the intensity of illumination at a point on the ground in line with the lamps and 12 m from the base on both sides of the lamps.

Solution:

Given data:

Luminous intensity, $I = 500$ CP.

Mounting height, $h = 10$ m.

Case (i):

From Fig. P.6.14:

$$d_1 = \sqrt{10^2 + 12^2}$$
$$= 15.62 \text{ m.}$$
$$\cos\theta_1 = \frac{h}{d_1} = \frac{10}{15.62} = 0.64.$$

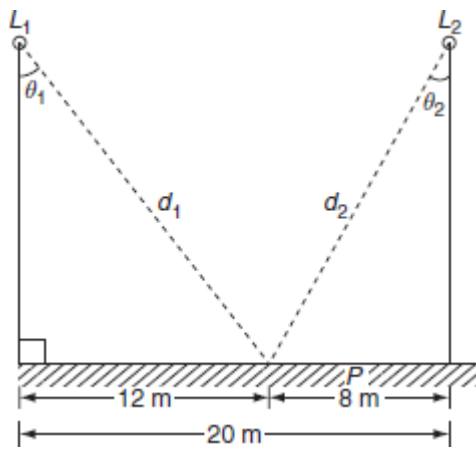

Fig. P.6.14

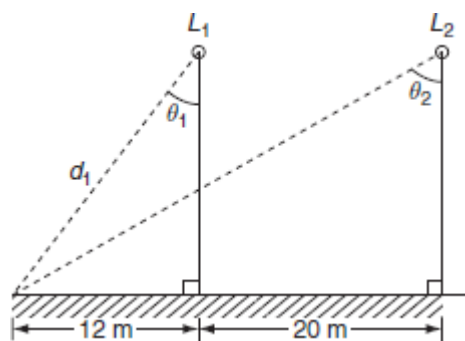

Fig. P.6.15

The illumination at 'P' due to lamp L_1 is:

$$\begin{aligned} E_1 &= \frac{I}{d_1^2} \cos\theta_1 \\ &= \frac{500}{(5.62)^2} \times 0.64 \\ &= 1.3115 \text{ lux.} \end{aligned}$$

$$\begin{aligned} d_2 &= \sqrt{8^2 + 10^2} = 12.806 \text{ m.} \\ \cos\theta_2 &= \frac{h}{d_2} = \frac{10}{12.806} = 0.780. \end{aligned}$$

The illumination at 'P' due to lamp L_2 is:

$$\begin{aligned} E_2 &= \frac{I}{d_2^2} \cos\theta_2 \\ &= \frac{500}{(12.806)^2} \times 0.78 \\ &= 2.378 \text{ lux.} \end{aligned}$$

$$\begin{aligned} \therefore \text{ The total illumination at the point 'P' } &= E_1 + E_2 \\ &= 1.3115 + 2.378 \\ &= 3.689 \text{ lux.} \end{aligned}$$

Case (ii):

From Fig. P.6.15:

$$d_2 = \sqrt{8^2 + 10^2} = 12.806 \text{ m.}$$

$$\cos\theta_2 = \frac{h}{d_2} = \frac{10}{12.806} = 0.780.$$

The illumination at 'P' due to lamp L_1 is:

$$\begin{aligned} E_1 &= \frac{I}{d_1^2} \times \cos\theta_1 \\ &= \frac{500}{(15.62)^2} \times 0.64 \\ &= 1.3115 \text{ lux.} \end{aligned}$$

$$d_2 = \sqrt{10^2 + 32^2} = 33.52 \text{ m.}$$

$$\cos\theta_2 = \frac{I}{d_2} = \frac{10}{33.52} = 0.298.$$

The illumination at 'P' due to the lamp ' L_2 ' is:

$$\begin{aligned} E_2 &= \frac{I}{d_2^2} \cos\theta_2 \\ &= \frac{500}{(33.52)^2} \times 0.298 \\ &= 0.1326 \text{ lux.} \end{aligned}$$

\therefore The total illumination at 'P' due to both lamps = $E_1 + E_2$

$$= 1.3115 + 0.1326$$

$$= 1.44 \text{ lux.}$$

Example 6.16: Two similar lamps having luminous intensity 500 CP in all directions below horizontal are mounted at a height of 8 m. What must be the spacing between the lamps so that the illumination on the ground midway between the lamps shall be at least one-half of the illumination directly below the lamp.

Solution:

Given data:

The candle power of lamp, $I = 600$ CP.

The mounting height of lamps from the ground, $H = 8$ m.

Let, the maximum spacing between the lamps = x m.

From Fig. P.6.16:

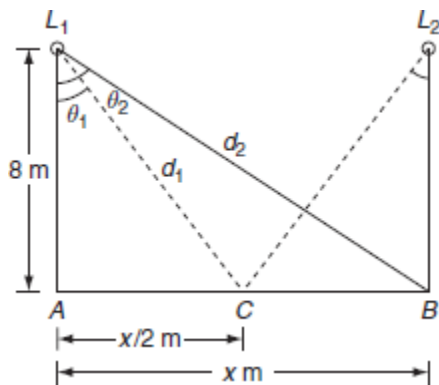

Fig. P.6.16

The illumination at 'C' due to the lamp ' L_1 ' is:

$$E_1 = \frac{I}{h^2} \cos^3 \theta_1$$

$$= \frac{600}{8^2} \times \frac{(8)^3}{[8^2 + (x/2)^2]^{3/2}}$$

The illumination ' E_2 ' at ' C ' due to the lamp ' L_2 ' is same as to ' E_1 '.

∴ The total illumination at ' C ' due to the lamps, L_1 and L_2 is:

$$E_C = 2 E_1$$

$$= 2 \times \left[\frac{600}{8^2} \times \frac{8^3}{[8^2 + (x/2)^2]^{3/2}} \right]$$

$$= \frac{9,600}{[8^2 + (x/2)^2]^{3/2}}$$

The illumination just below the lamp, L_2 is:

E_B = the illumination due to lamp L_1 + the illumination due to lamp L_2 :

$$= \frac{600}{8^2} \times \frac{8^3}{[8^2 + x^2]^{3/2}} + \frac{600}{8^2}$$

But, given $E_C = \frac{1}{2} E_B$.

$$\therefore \frac{9,600}{\left[8^2 + \left(\frac{x}{2}\right)^2\right]^{\frac{3}{2}}} = \frac{1}{2} \left[\frac{4,800}{\left[8^2 + x^2\right]^{\frac{3}{2}}} + 9.375 \right]$$

$$\frac{9,600}{\left[8^2 + \left(\frac{x}{2}\right)^2\right]^{\frac{3}{2}}} = \frac{2400}{\left[8^2 + x^2\right]^{\frac{3}{2}}} + 4.6875.$$

Example 6.17: Find the height at which a light source having uniform spherical distribution should be placed over a floor in order that the intensity of horizontal illumination at a given distance from its vertical line may be greatest.

Solution:

Let the luminous intensity of the lamp = 'I' CP.

The illumination at the point 'A' due to source is:

$$E_A = \frac{I}{\sqrt{h^2 + x^2}} \cdot \cos\theta$$

$$= \frac{I}{h^2} \cos^3\theta.$$

But, from Fig. P.6.17:

$$\cos\theta = \frac{h}{\sqrt{h^2 + x^2}}.$$

$$\therefore E_A = \frac{I}{h^2} \times \left[\frac{h}{\sqrt{h^2 + x^2}} \right]^3$$

$$= I \times \frac{h}{(h^2 + x^2)^{\frac{3}{2}}}.$$

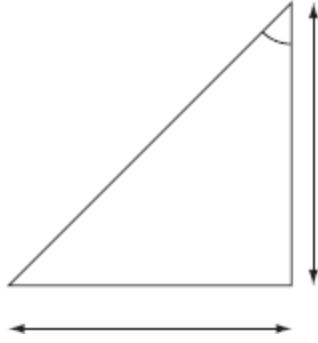

Fig. P.6.17

Given that, the illumination at a point away from the base of lamp may be the greatest:

$$\begin{aligned}
 \therefore \frac{dE_A}{dh} &= 0 \\
 &= I \left[\frac{h}{dh} \left[\frac{h}{(h^2 + x^2)^{3/2}} \right] \right] = 0 \\
 &= \frac{(h^2 + x^2)^{3/2} \cdot 1 - h \cdot \frac{3}{2} (h^2 + x^2)^{1/2} \cdot 2h}{\left\{ (h^2 + x^2)^{3/2} \right\}^2} = 0 \\
 &= (h^2 + x^2)^{1/2} \cdot [(h^2 + x^2) - 3h^2] = 0 \\
 &= x^2 - 2h^2 = 0 \\
 &\Rightarrow x^2 = 2h^2 \\
 &\Rightarrow h = \frac{x}{\sqrt{2}} = 0.707x
 \end{aligned}$$

$$\therefore h = 0.707x.$$

Example 6.18: A lamp of 250 candela is placed 2 m below a plane mirror that reflects 60% of light falling on it. The lamp is hung at 6 m above ground. Find the illumination at a point on the ground 8 m away from the point vertically below the lamp.

Solution:

Figure P.6.18 shows the lamp and the mirror arrangements. Here, the lamp 'L' produces an image 'L₁', then the height of the image from the ground = 8 + 2 = 10 m.

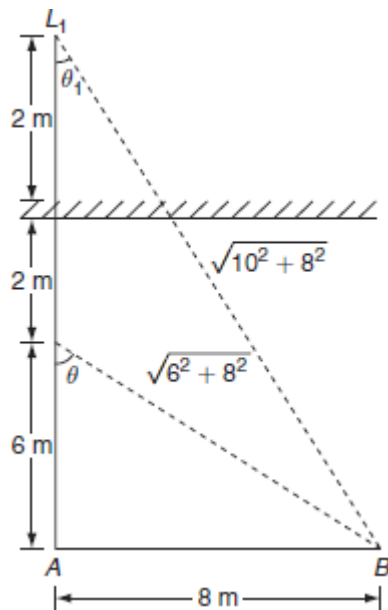

Fig. P.6.18

And L₁ acts as the secondary sources of light whose candle power is equals to $0.85 \times$ CP of the lamp 'L'.

i.e., $0.85 \times 250 = 212.5$ CP.

\therefore The illumination at the point 'B', '8' m away from the lamp = illumination at 'B' due to L + the illumination at 'B' due to L₁:

$$\begin{aligned}
&= \frac{250}{(\sqrt{6^2 + 8^2})^2} \times \frac{6}{\sqrt{6^2 + 8^2}} + \frac{212.5}{(\sqrt{10^2 + 8^2})^2} \times \frac{10}{\sqrt{10^2 + 8^2}} \\
&= \frac{1500}{(6^2 + 8^2)^{3/2}} + \frac{2125}{(10^2 + 8^2)^{3/2}} \\
&= 1.5 + 1.0117 \\
&= 2.5117 \text{ lux.}
\end{aligned}$$

Example 6.19: A light source with an intensity uniform in all direction is mounted at a height of 20 ms above a horizontal surface. Two points 'A' and 'B' both lie on the surface with point A directly beneath the source. How far is B from A if the illumination at 'B' is only 1/15th as great as A?

Solution:

Let the luminous intensity of the lamp 'L' be 'I' candela and the distance of the point of illumination from the base of the lamp is 'x' m (Fig. P.6.19).

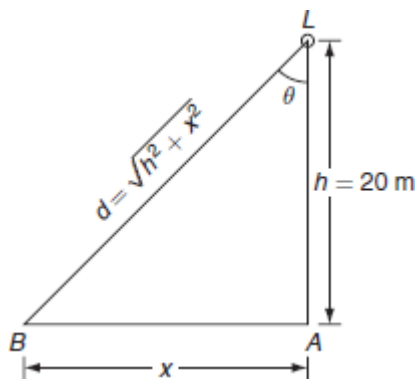

Fig. P.6.19

The illumination at the point 'A' due to the lamp 'L' is:

$$E_A = \frac{I}{h^2} = \frac{I}{20^2} = \frac{I}{400}.$$

The illumination at the point 'B' due to the lamp 'L' is:

$$E_B = \frac{I}{h^2} \cos^3 \theta$$

$$E_B = \frac{I}{(20)^2} \left[\frac{20}{\sqrt{(20)^2 + x^2}} \right]^3.$$

Given, $E_B = \frac{1}{15} E_A$

$$\frac{20I}{(20^2 + x^2)^{3/2}} = \frac{1}{15} \times \frac{I}{400}$$

$$20 \times 15 \times 400 = (20^2 + x^2)^{3/2}$$

$$2143.98 = 20^2 + x^2.$$

$$x^2 = 1743.98$$

$$x = 41.76 \text{ m.}$$

Example 6.20: Two similar lamps having uniform intensity 500 CP in all directions below the horizontal are mounted at a height of 4 m. What must be the maximum spacing between the lamps so that the illumination on the ground midway between the lamps shall be at least one-half the illuminations directly under the lamps?

Solution:

The candle power of the lamp = 500 CP (Fig. P.6.20).

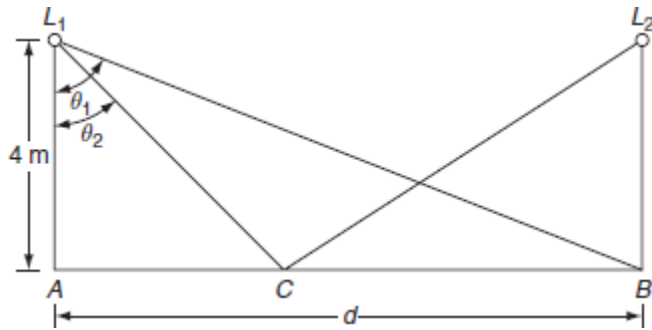

Fig. P.6.20

The height of the lamps from the ground, $h = 4$ m.

Let the maximum spacing between the lamps be of ' d ' meters.

The illumination at the point ' C ' in between the lamp post

$$= 2 \times \text{Illumination due to either } L_1 \text{ or } L_2$$

$$E_C = 2 \times \frac{500}{4^2} \times \frac{4^3}{\left[4^2 + (d/2)^2\right]^{3/2}} = \frac{4000}{\left[4^2 + d^2/4\right]^{3/2}}$$

The illumination just below the lamp L_2 is:

E_B = the illumination due to the lamp L_1 + the illumination due to the lamp L_2

$$\begin{aligned} &= \frac{500}{4^2} \times \frac{4}{\left[4^2 + d^2/2\right]^{3/2}} + \frac{500}{4^2} \\ &= \frac{2,000}{(4^2 + d^2)^{3/2}} + 31.25. \end{aligned}$$

Given:

$$E_C = \frac{1}{2} E_B$$
$$\frac{4000}{[4^2 + d^2/4]^{3/2}} = \frac{1}{2} \left[31.25 + \frac{200}{(4^2 + d^2)^{3/2}} \right]$$
$$\frac{4,000}{(4^2 + d^2/4)^{3/2}} = 15.625 + \frac{1,000}{(4^2 + d^2)^{3/2}}$$

$$\therefore d = 9.56 \text{ m.}$$

Example 6.21: A lamp with a reflector is mounted 10 m above the center of a circular area of 30-m diameter. If the combination of lamp and reflector gives a uniform CP of 1,200 over circular area, determine the maximum and minimum illumination produced.

Solution:

The mounting height of the lamp $h = 10$ m (Fig. P.6.21, P.6.22).

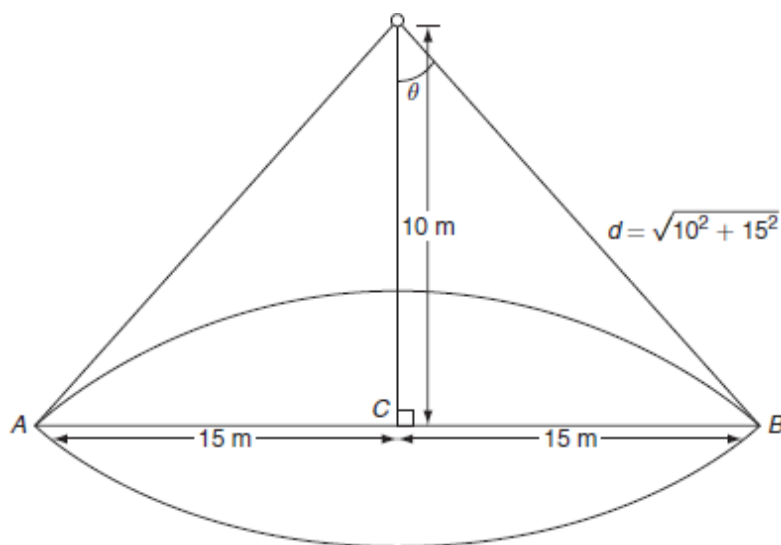

Fig. P.6.21

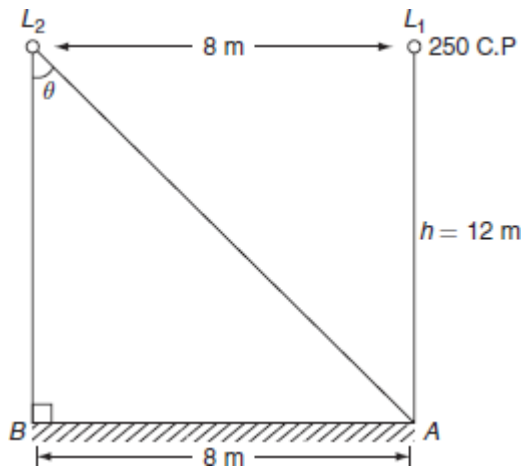

Fig. P.6.22

The diameter of the circular area = 30 m.

The candle power of the lamp $I = 1,200$ CP.

The maximum illumination occur just directly below the lamp, i.e., at point 'C' is:

$$E_c = \frac{I}{d^2} = \frac{I}{h^2} = \frac{1200}{10^2} = 12 \text{ lux.}$$

Minimum Illumination will occur at the periphery of the circular area, i.e., at A (or) B.

$$\begin{aligned} \therefore E_A = E_B &= \frac{I}{d^2} \cos\theta \\ &= \frac{1200}{\left(\sqrt{10^2 + 15^2}\right)^2} \times \frac{10}{\sqrt{10^2 + 15^2}} \end{aligned}$$

$$= \frac{12,000}{(10^2 + 15^2)^{3/2}}$$

$$= 2.048 \text{ lux.}$$

Example 6.22: Two lamps hung at a height of 12 m from the floor level. The distance between the lamps is 8 m. Lamp one is of 250 CP. If the illumination on the floor vertically below this lamp is 40 lux, find the CP of the second lamp.

Solution:

Given data:

The candle power of the lamp, $I = 250 \text{ CP}$.

The intensity of L_1 illumination just below the lamp $L_1 = 40 \text{ lux}$.

Let CP of $L_2 = I \text{ CP}$.

\therefore The illumination at the point A = the illumination due to the lamp L_1 + the illumination due to the lamp L_2 :

$$40 = \frac{I_1}{h^2} + \frac{I}{h^2} \cos^3 \theta$$

$$= \frac{250}{(12)^2} + \frac{I}{(12)^2} \left(\frac{12}{\sqrt{12^2 + 8^2}} \right)^3$$

$$= 1.736 + \frac{12I}{14.42}$$

$$\frac{12I}{14.42} = 38.263$$

$$I = 551.76 \text{ C.P.}$$

POLAR CURVES

The luminous flux emitted by a source can be determined using the intensity distribution curve. Till now we assumed that the luminous intensity or the candle power from a source is distributed uniformly over the surrounding surface. But due to its not

uniform in all directions. The luminous intensity or the distribution of the light can be represented with the help of the polar curves.

The polar curves are drawn by taking luminous intensities in various directions at an equal angular displacement in the sphere. A radial ordinate pointing in any particular direction on a polar curve represents the luminous intensity of the source when it is viewed from that direction. Accordingly, there are two different types of polar curves and they are:

1. A curve is plotted between the candle power and the angular position, if the luminous intensity, i.e., candle power is measured in the horizontal plane about the vertical axis, called '*horizontal polar curve*'.
2. curve is plotted between the candle power, if it is measured in the vertical plane and the angular position is known as '*vertical polar curve*'.

Figure 6.12 shows the typical polar curves for an ordinary lamp.

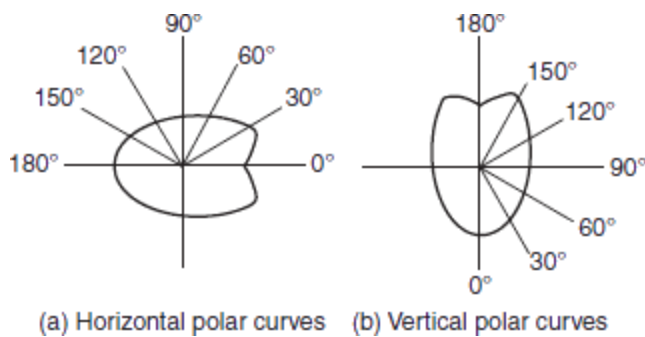

Fig Polar curves

Depression at 180° in the vertical polar curve is due to the lamp holder. Slight depression at 0° in horizontal polar curve is because of coiled coil filament.

Polar curves are used to determine the actual illumination of a surface by employing the candle power in that particular direction as read from the vertical polar curve. These are also used to determine mean horizontal candle power (MHCP) and mean spherical candle power (MSCP).

The mean horizontal candle power of a lamp can be determined from the horizontal polar curve by considering the mean value of all the candle powers in a horizontal direction.

The mean spherical candle power of a symmetrical source of a light can be found out from the polar curve by means of a Rousseau's construction.

Rousseau's construction

Let us consider a vertical polar curve is in the form of two lobes symmetrical about XOX' axis. A simple Rousseau's curve is shown in Fig. 6.13.

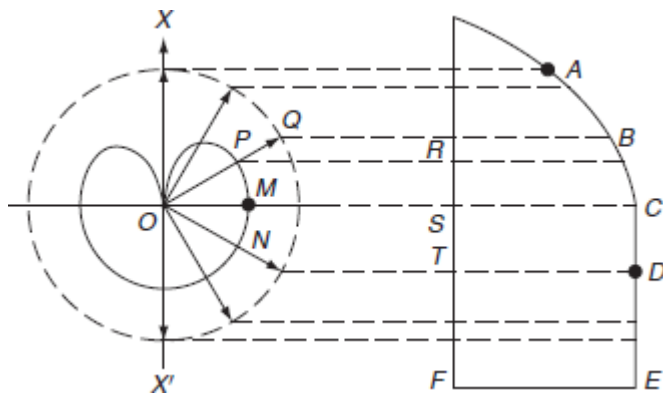

Fig. 6.13 Rousseau's curve

Rules for constructing the Rousseau's curve are as follows:

1. Draw a circle with any convenient radius and with 'O' as center.
2. Draw a line 'AF' parallel to the axis XOX' and is equal to the diameter of the circle.
3. Draw any line 'OPQ' in such a way that the line meeting the circle at point 'Q'. Now let the projection be 'R' onto the parallel line 'AF'.
4. Erect an ordinate at 'R' as, $RB = OP$.
5. Now from this line 'AF' ordinate equals to the corresponding radius on the polar curve are setup such as $SC = OM$, $TD = ON$, and so on.
6. The curve $ABCDEFA$ so obtained by joining these ordinates is known as Rousseau's curve.

The mean ordinate of this curve gives the mean spherical candle power (MSCP) of the lamp having polar curve given in Fig. 6.13.

The mean ordinate of the curve:

$$= \frac{\text{area of } ABCDEFA}{\text{length of } AF}.$$

The area under the Rousseau's curve can be determined by Simpson's rule.

PHOTOMETRY

Photometry involves the measurement of candle power or luminous intensity of a given source. Now, we shall discuss the comparison and measurement of the candle powers.

The candle power of a given source in a particular direction can be measured by the comparison with a standard or substandard source. In order to eliminate the errors due to the reflected light, the experiment is conducted in a dark room with dead black walls and ceiling. The comparison of the test lamp with the standard lamp can be done by employing a photometer bench and some form of photometer.

Principle of simple photometer

The photometer bench essentially consists of two steel rods with 2- to 3-m long. This bench carries stands or saddles for holding two sources (test and standard lamps), the carriage for the photometer head and any other apparatus employed in making measurements. Graduated scale in centimeters or millimeters in one of the bar strips. The circular table is provided with a large graduated scale in degrees round its edge so that the angle of the rotation of lamp from the axis of bench can be measured.

The photometer bench should be rigid so that the source being compared may be free from vibration. The photometer head should be capable of moving smoothly and the photometer head acts as screen for the comparison of the illumination of the standard lamp and the test lamp.

The principle methods of measurement are based upon the inverse square law.

The photometer bench consists of two sources, the standard source 'S' whose candle power is known and the other source 'T' whose candle power is to be determined. The photometer head acts as screen is moved in between the two fixed sources until the illumination on both the sides of screen is same. A simple arrangement for the measurement of the candle power of the test source is shown in Fig. 6.14.

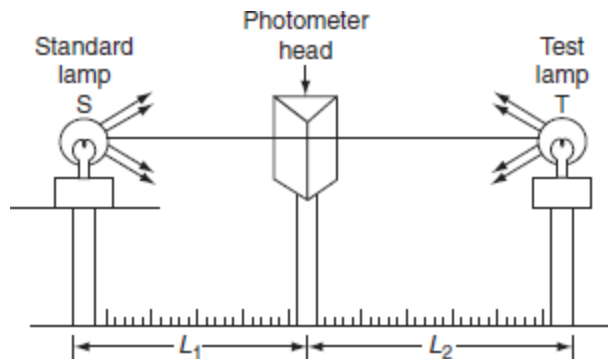

Fig. Measurement of candle power

If the distances of the standard source 'S' and the test source 'T' from the photometer head are L_1 and L_2 , respectively, then, according to the inverse square law, if the illumination on both the sides of screen are equal then the candle power of the source is proportional to the square of the distance between the source and the photometer head.

The CP of standard source $\propto L_1^2$.

The CP of test source $\propto L_2^2$.

$$\therefore \frac{\text{CP of test source}}{\text{CP of standard source}} = \frac{L_2^2}{L_1^2}$$

$$\therefore \text{CP of test source} = S \times \frac{L_2^2}{L_1^2}$$

In order to obtain the accurate candle power of test source, the distance of the sources from the photometer head should be measured accurately.

Photometer heads

The photometer heads that are most common in use are:

1. Bunsen grease spot photometer.
2. Lumer-Brodhun photometer.
3. Flicker photometer.

The first two are best suited for use, if the two sources to be compared give the light of same or approximately similar colors. Increase the light from the two sources to be compared differ in color, a flicker photometer is best suited.

(i) *Bunsen grease spot photometer*

Bunsen photometer consists of a tissue paper, with a spot of grease or wax at its center. It held vertically in a carrier between the two light sources to be compared. The central spot will appear dark on the side, having illumination in excess when seen from the other side. Then, the observer will adjust the position of photometer head in such a way that until the semitransparent spot and the opaque parts of the paper are equally bright then the grease spot is invisible, i.e., same contrast in brightness is got between the spot and the disc when seen from each sides as shown in Fig. 6.15. The distance of the photometer from the two sources is measured. Hence, the candle power of test source is then determined by using relation:

$$\text{The CP of the test lamp} = \text{the CP of the standard lamp} \times \left(\frac{L_2}{L_1}\right)^2.$$

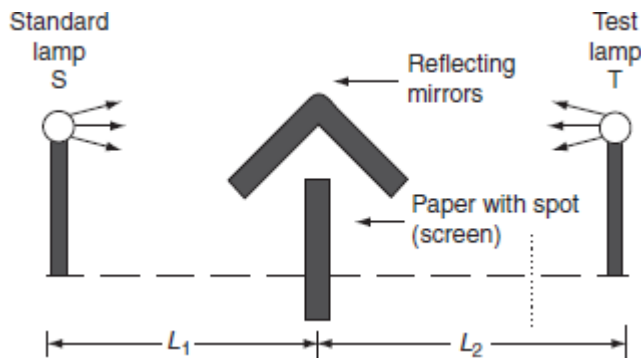

Fig. Bunsen grease spot photometer

The use of two reflecting mirrors above the photometer head makes it perhaps the accurate method, since the two sides of spot and position of the head can be viewed simultaneously.

(ii) *Lumer-Brodhun photometer*

There are two types of Lumen–Brodhun photometer heads.

1. Equality of brightness type.
2. Contrast type.

The Contrast type is more accurate and therefore, extensively used in the photometric measurements.

(a) Equality of brightness type photometer head

The photometer head essentially consists of screen made of plaster of Paris, two mirrors M_1 and M_2 , glass cube or compound prism, and a telescope.

The compound prism made up of two right-angled glass prisms held together, one of which has sand blasted pattern on its face, i.e., principal surface as spherical with small flat portion at the center and the other is perfectly plain. A typical Lumer–Brodhun photometer head is shown in Fig. 6.16.

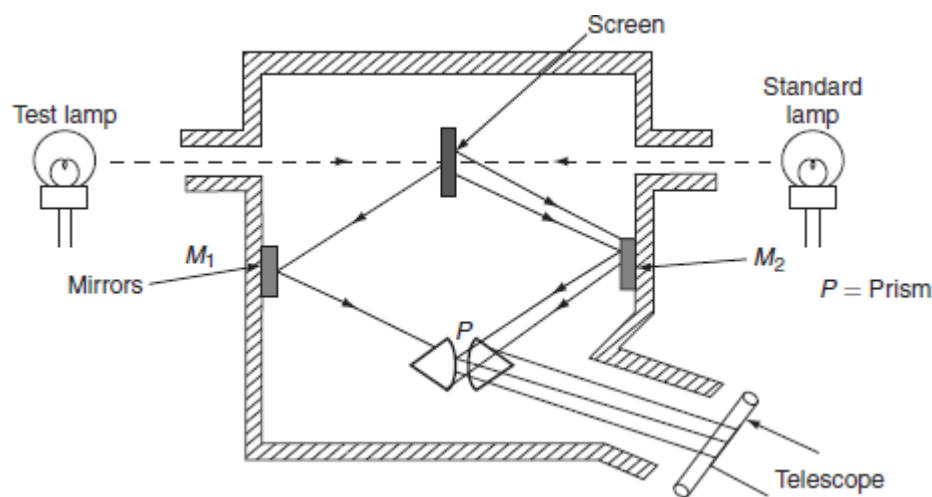

Fig. 6.16 Lumer–Brodhun photometer (equality of brightness)

The two sides of the screen are illuminated by two sources such as the standard and test lamps as shown in Fig. 6.16. The luminous flux lines emitting from the two sources are falling on the screen directly and reflected by it onto the mirrors M_1 and M_2 , which in turn reflects the same onto the compound prism.

The light ray reflected by M_1 is passing through the plain prism and the light ray reflected by M_2 is falling on the spherical surface of the other prism and is reflected again which pass through the telescope. Thus, observer view the center portion of the circular

area illuminated by the test lamp and the outer ring is illuminated by the standard lamp. The positioning of the photometer head is adjusted in such a way that the dividing line between the center portion and the surrounding disappears. The disappearance of dividing line indicates the same type of color of the test lamp and the standard lamp.

Now, the distance of photometer head from the two sources are measured and the candle power or luminous intensity of test lamp can be calculated by using inverse square law.

(b) Contrast type photometer head

Similar to the equal brightness type photometer, it consists of a compound prism, which is made up of two right-angled glass prism. The joining surfaces of the two right-angled glass prisms are flat, but one of the prism has its hypotenuses surface etched away at *A, B, and C* to get pattern of the type shown in Fig. 6.17.

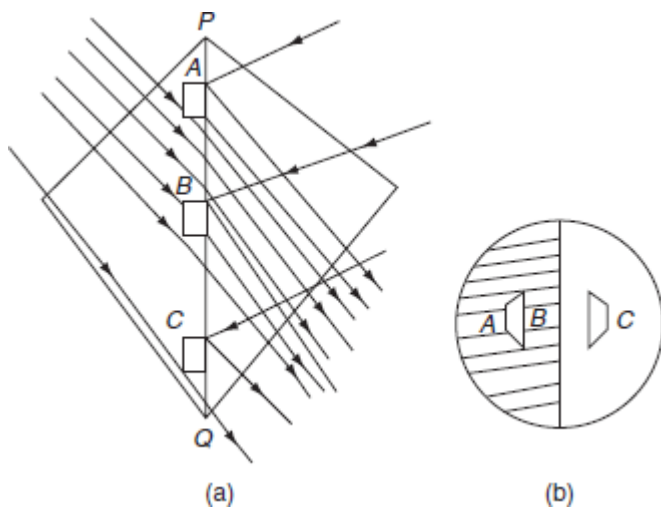

Fig. 6.17 Lumen–Brodhun photometer head (Contrast type)

As in case of equal brightness type, the light falling on the both sides of the screen passes through the unetched portion of the joining surface and gets reflected at the etched surfaces (*A, B, and C*). *P* and *Q* are the sheets of glass that give little reflected light to maintain the difference between the illuminations of both the etched and the unetched portions. If the illumination of the surfaces of the prism is different, then the etched portion will have difference in illumination as compared to unetched portion.

If the balance is got, the difference in illuminations of both etched and unetched portions are same and equal to half of the circular area; then, the photometer head is said to be in a balance position. When the balance position is altered, the difference or the contrast in the illumination of area 'C' and its surrounding area decreases. In addition, the contrast illumination area AB and the inner trapezium will increase. Generally, in balanced position, the contrast is about 8%. The position of photometer head is adjusted in such a way that the equal contrast is obtained between the etched and the unetched portions. This contrast type of the head gives accuracy within 1%.

(iii) *Flicker photometer*

The flicker photometers are employed when two sources giving light of different colors to be compared. The color contrast between two lights do not affect their working is the unit feature of the flicker photometer. This is because the color contrast between the two alternating fields of the light disappears at a lower speed of alternation than does a contrast of brightness.

A typically used flicker photometer is a Simmance–Abady flicker photometer, where used rotating disc made up of plaster of Paris. The dick is in the form of a double-truncated cone as shown in Fig. 6.18. The truncated portions of cone are fitted together to form the disc. The disc is continuously rotated at the required minimum speed by small motor in between the two sources to be compared. Each half of the disc is illuminated from one source and the eye is presented with the two fields of the light to be compared alternately. When the two halves are having unequal illuminations a flicker appears. Now, the disc is rotated to that position where the flicker disappears. When the two halves of the disc are illuminated equally and then the candle power of the test source can be calculated by measuring the distances of the disc from the two sources in the usual manner.

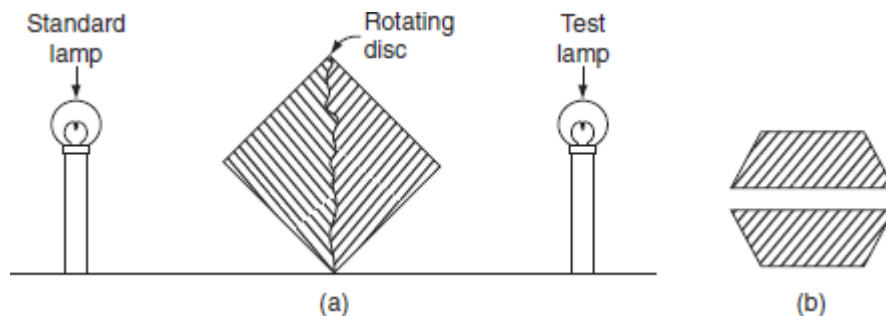

Fig. 6.18 Flicker photometer

Discharge lamps

In this method, the application of suitable voltage, known as *ignition voltage*, across the two electrodes results in a discharge through the gas, this is accompanied by electromagnetic radiation.

Here, candle power, i.e., the color intensity of the light emitted depends upon the nature of the gas. These sources do not depend on the temperature for higher efficiencies.

Ex: Neon lamp, sodium vapor lamp, mercury vapor lamp, and florescent lamp.

SHORT QUESTIONS AND ANSWERS

1. What is light?

It is defined as the radiant energy from a hot body that produces the visual sensation upon the human eye. It is expressed in lumen-hours and it analogous to watt-hours, which denoted by the symbol 'Q'.

2. Write the expression that shows the relation between solid angle and plane angle.

$$\omega = 2\pi \left(1 - \cos \frac{\theta}{2}\right).$$

3. States the inverse square law of illumination.

This law states that 'the illumination of a surface is inversely proportional to the square of distance between the surface and a point source'.

4. States the Lambert's cosine law of illumination.

This law states that 'illumination, E at any pint on a surface is directly proportional to the cosine of the angle between the normal at that point and the line of flux'.

5. Define the MSCP.

It is defined as the mean of the candle power of the source in all directions in horizontal plane.

6. Define the MHCP.

It is defined as the mean of the candle power of the source in all directions in all planes.

7. Define the MHSCP.

It is defined as the mean of the candle power of the source in all directions above or below the horizontal plane.

8. What is the need of polar curves?

The luminous flux emitted by a source can be determined from the intensity distribution curve. But the luminous intensity or the candle power of any practical lamp is not uniform in all directions due to its unsymmetrical shape. The luminous intensity or the distribution of such sources can be determined by polar curves.

9. List out the types of photometers used for the photometric measurements.

The photometer heads that are most common in use are:

1. Bunsen grease spot photometer.
2. Lumer–Brodhun photometer.
3. Flicker photometer.

What is photometry?

Photometry means the measurement of the candle power or the luminous intensity of a given source. The candle power of any test source is measured with the comparison of a standard source.

List out the various photocells used for photometric measurements.

Generally used photocells for photometric measurements are:

0. photo voltaic cell and
1. photo emissive cell.

The photo voltaic cell is most widely used one because of its simplicity and associated circuits.

Define plane angle.

A plane angle is the angle subtended at a point in a plane by two converging lines. It is denoted by the Greek letter ' θ ' (theta) and is usually measured in degrees or radians.

$$\therefore \text{Plane angle}(\theta) = \frac{\text{arc}}{\text{radius}}.$$

Define solid angle.

Solid angle is the angle subtended at a point in space by an area, i.e., the angle enclosed in the volume formed by numerous lines lying on the surface and meeting at the point. It is usually denoted by symbol ' ω ', and is measured in steradian.

$$\therefore \text{Solid angle}(\omega) = \frac{\text{area}}{(\text{radius})^2}.$$

Define luminous flux.

It is defined as the energy in the form of light waves radiated per second from a luminous body. It is represented by the symbol ' ϕ ' and measured in lumens.

Define luminous intensity.

Luminous intensity in a given dissection is defined as the luminous flux emitted by the source per unit solid angle.

$$\text{Luminous intensity } (I) = \frac{\phi}{\omega} \text{ lumen/steradian or candela.}$$

Define illumination.

Illumination is defined as the luminous flux received by the surface per unit area.

$$\begin{aligned} \text{Illumination, } E &= \frac{\text{luminous flux}}{\text{area}} \\ &= \frac{\phi}{A} = \frac{CP \times \omega}{A} \text{ lux.} \end{aligned}$$

Define lamp efficiency.

It is defined as the ratio of total luminous flux emitting from the source to its electrical power input in watts.

$$\therefore \text{Lamp efficiency} = \frac{\text{luminous flux}}{\text{power input}}$$

Various Illumination Methods

INTRODUCTION

Light plays major role in human life. Natural light restricted for some duration in a day, it is very difficult to do any work by human being without light. So, it is necessary to have substitute for natural light. Light from incandescent bodies produced electrically, which playing important role in everyday life due to its controlled output, reliability, and cleanliness nowadays; various sources are producing artificial light. Each source has its own characteristics and specific importance.

TYPES OF SOURCES OF ILLUMINATION

Usually in a broad sense, based upon the way of producing the light by electricity, the sources of light are classified into following four types.

Electric arc lamps

The ionization of air present between the two electrodes produces an arc and provides intense light.

Incandescent lamps

When the filaments of these lamps are heated to high temperature, they emit light that falls in the visible region of wavelength. Tungsten-filament lamps are operating on this principle.

Gaseous discharge lamps

When an electric current is made to pass through a gas or metal vapor, it produces visible radiation by discharge takes place in the gas vapor. Sodium and mercury vapor lamps operate on this principle.

Fluorescent lamps

Certain materials like phosphor powders exposed to ultraviolet rays emits the absorbed energy into visible radiations fall in the visible range of wavelength. This principle is employed in fluorescent lamps.

ARC LAMPS

In arc lamps, the electrodes are in contact with each other and are separated by some distance apart; the electric current is made to flow through these two electrodes. The discharge is allowed to take place in the atmosphere where there are the production of a very intense light and a considerable amount of UV radiation, when an arc is struck between two electrodes.

The arcs maintain current and is very efficient source of light. They are used in search lights, projection lamps, and other special purpose lamps such as those in flash cameras.

Generally, used arc lamps are:

1. carbon arc lamp,
2. flame arc lamp, and
3. magnetic arc lamp.

Carbon arc lamp

Carbon arc lamp consists of two hard rod-type electrodes made up of carbon. Two electrodes are placed end to end and are connected to the DC supply. The positive electrode is of a large size than that of the negative electrode. The carbon electrodes used with AC supply are of the same size as that of the DC supply. The DC supply across the two electrodes must not be less than 45 V. When electric current passes through the electrodes are in contact and then withdrawn apart about 2–3 mm an arc is established between the two rods.

The two edges of the rods becomes incandescence due to the high resistance offered by rods as shown in [Fig. 7.1](#) by transfer of carbon particles from one rod to the other. It is observed that carbon particles transfer from the positive rod to the negative one. So that the positive electrode gets consumed earlier than the negative electrode. Hence, the positive electrode is of twice the diameter than that of the negative electrode.

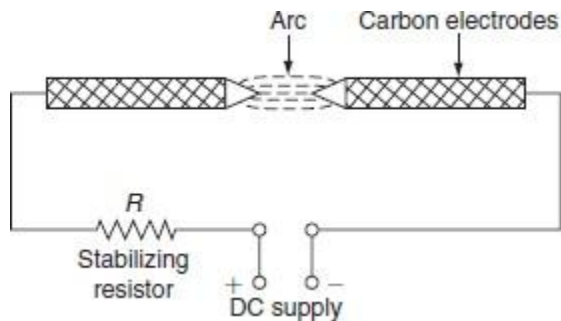

Fig Carbon arc lamp

In case of AC supply, the rate of consumption of the two electrodes is same; therefore, the cross-section of the two electrodes is same. A resistance 'R' is connected in series with the electrode for stabilizing the arc. As current increases, the vaporizing rate of carbon increases, which decreases the resistance so much, then voltage drop across the arc decreases. So, to maintain the arc between the two electrodes, series resistance should be necessarily connected.

For maintaining the arc, the necessary voltage required is:

$$V = (39 + 2.8 l) \text{ V,}$$

where l is the length of the arc. The voltage drop across the arc is 60 V, the temperature of the positive electrode is 3,500 – 4,200°C, and the temperature of the negative electrode is 2,500°C. The luminous efficiency of such lamps is 9–12 lumens/W. This low luminous efficiency is due to the service resistance provided in DC supply while in case of AC supply, an inductor is used in place of a resistor. In carbon arc lamps, 85% of the light is given out by the positive electrode, 10% of the light is given out by the negative electrodes, and 5% of the light is given out by the air.

Flame arc lamp

The electrodes used in flame arc lamp are made up of 85% of carbon and 15% of fluoride. This fluoride is also known as flame material; it has the efficient property that radiates light energy from high heated arc stream. Generally, the core type electrodes are used and the cavities are filled with fluoride. The principle of operation of the flame arc lamp is similar to the carbon arc lamp. When the arc is established between the electrodes, both fluoride and carbon get vaporized and give out very high luminous intensities. The color output of the flame arc lamps depends upon the flame materials. The luminous efficiency of such lamp is 8 lumens/W. A simple flame arc lamp is shown in Fig. 7.2. Resistance is connected in service with the electrodes to stabilize the arc.

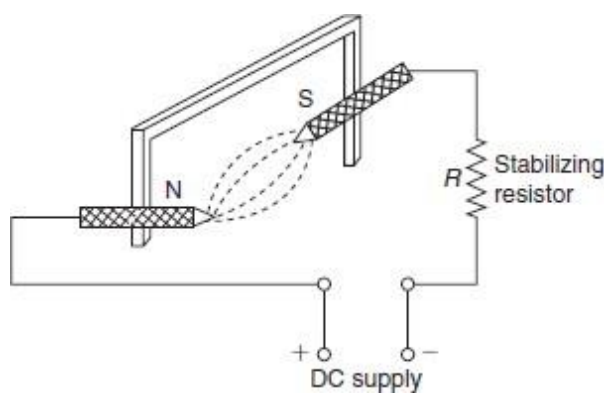

Fig. 7.2 Flame arc lamp

Magnetic arc lamp

The principle of the operation of the magnetic arc lamp is similar to the carbon arc lamp. This lamp consists of positive electrode that is made up of copper and negative electrode that is made up of magnetic oxide of iron. Light energy radiated out when the arc is struck between the two electrodes. These are rarely used lamps.

INCANDESCENT LAMP

These lamps are temperature-dependent sources. When electric current is made to flow through a fine metallic wire, which is known as *filament*, its temperature increases. At low temperatures, it emits only heat energy, but at very high temperature, the metallic wire emits both heat and light energy. These incandescent lamps are also known as *temperature radiators*.

Choice of material for filament

The materials commonly used as filament for incandescent lamps are carbon, tantalum, tungsten, and osmium.

The materials used for the filament of the incandescent lamp have the following properties.

- The melting point of the filament material should be high.
- The temperature coefficient of the material should be low.
- It should be high resistive material.
- The material should possess good mechanical strength to withstand vibrations.
- The material should be ductile.

Comparisons of carbon, osmium, tantalum, and tungsten used for making the filament

Carbon

- Carbon has high melting point of 3,500°C; even though, its melting point is high, carbon starts disintegration at very fast rate beyond its working temperature of 1,800°C.
- Its resistance decreases with increase in temperature, i.e., its temperature coefficient of resistivity is negative, so that it draws more current from the supply. The temperature coefficient (α) is -0.0002 to -0.0008 .

- The efficiency of carbon filament lamp is low; because of its low operating temperature, large electrical input is required. The commercial efficiency of carbon lamp is 3 – 4.5 lumens/W approximately.
- Carbon has high resistivity (ρ), which is about 1,000–7,000 $\mu\Omega$ -cm and its density is 1.7–3.5.

Osmium

- The melting point of osmium is 2,600°C.
- It is very rare and expensive metal.
- The average efficiency of osmium lamp is 5 lumens/W.

Tantalum

- The melting point of tantalum is 3,000°C.
- Resistivity (ρ) is 12.5 $\mu\Omega$ -cm.
- The main drawback of the negative temperature coefficient of carbon is overcome in tantalum. It has positive temperature coefficient (α) and its value is 0.0036.
- The density of tantalum is 16.6.
- The efficiency of tantalum lamp is 2 lumens/W.

Tungsten

- The working temperature of tungsten is 2,500–3,000°C.
- Its resistance at working temperature is about 12–15 times the cold resistance.
- It has positive temperature coefficient of resistance of 0.0045.
- Its resistivity is 5.6 12.5 $\mu\Omega$ -cm.
- The density of tungsten is 19.3.
- The efficiency of tantalum when working at 2,000°C is 18 lumens/W.
- Its vapor pressure is low when compared to carbon.

In fact, the carbon lamp is the first lamp introduced by Thomas Alva Edison in 1879, owing to two drawbacks, tungsten radiates more energy in visible spectrum and somewhat less in infrared spectrum so that there was a switch over in infrared spectrum so that there was a switch over from carbon filament to tungsten filament. Nowadays, tungsten filament lamps are widely used incandescent lamps.

The chemically pure tungsten is very strong and fragile. In order to make it into ductile, tungsten oxide is first reduced in the form of gray powder in the atmosphere of hydrogen and this powder is pressed in steel mold for small bars; the mechanical strength of these bars can be improved by heating them to their melting point and then hammered at red-hot position and re-rolled into wires.

Construction

Figure 7.3 shows the construction of the pure tungsten filament incandescent lamp. It consists of an evacuated glass bulb and an aluminum or brass cap is provided with two pins to insert the bulb into the socket. The inner side of the bulb consists of a tungsten filament and the support wires are made of molybdenum to hold the filament in proper position. A glass button is provided in which the support wires are inserted. A stem tube forms an air-tight seal around the filament whenever the glass is melted.

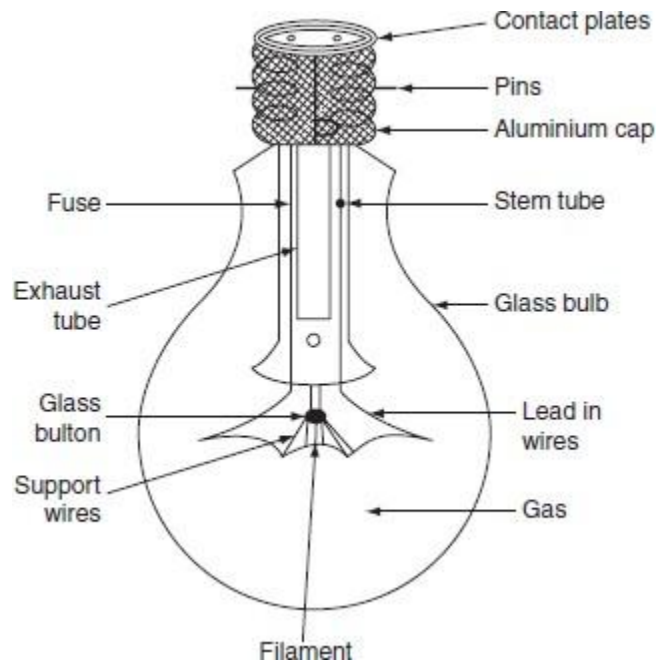

Fig. 7.3 Incandescent lamp

Operation

When electric current is made to flow through the fine metallic tungsten filament, its temperature increases. At very high temperature, the filament emits both heat and light radiations, which fall in the visible region. The maximum temperature at which the filament can be worked without oxidization is $2,000^{\circ}\text{C}$, i.e., beyond this temperature, the tungsten filament blackens the inside of the bulb. The tungsten filament lamps can be operated efficiently beyond $2,000^{\circ}\text{C}$, it can be attained by inserting a small quantity of inert gas nitrogen with small quantity of organ. But if gas is inserted instead of vacuum in the inner side of the bulb, the heat of the lamp is conducted away and it reduces the efficiency of the lamp. To reduce this loss of heat by conduction and convection, as far as possible, the filament should be so wound that it takes very little space. This is achieved by using a single-coil filament instead of a straight wire filament as shown in Fig.

7.4(a). This single-coil filament is used in vacuum bulbs up to 25 W and gas filled bulbs from 300 to 1,000 W.

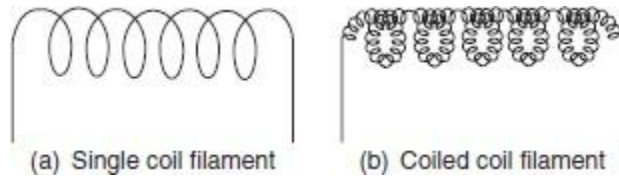

Fig. 7.4 Various filaments used in incandescent lamps

On further development of the incandescent lamps, the shortening of the length of the filament was achieved by adopting a coiled coil or a double coil filament as shown in [Fig. 7.4\(b\)](#). The use of coiled coil filament not only improves the efficiency of the lamp but also reduces the number of filament supports and thus simplified interior construction because the double coil reduces the filament mounting length in the ratio of 1:25 as compared to the straight wire filaments.

Usually, the tungsten filament lamp suffers from ‘aging effect’, the output of the light an incandescent lamp decreases as the lamp ages. The output of the light of the lamp decreases due to two reasons.

- At very high temperature, the vaporization of filament decreases the coil diameter so that resistance of the filament increases and hence its draws less current from the supply, so the temperature of the filament and the light output of the bulb decrease.
- The current drawn from the mains and the power consumed by the filament decrease, which decrease the efficiency of the lamp with the passage of time. In addition, the evaporation of the filament at high temperature blackens the inside of the bulb.

The effects of voltage variations

The variations in normal supply voltages will affect the operating characteristics of incandescent lamps. The performance characteristic of an incandescent lamp, when it is subjected to voltage other than normal voltage, is shown in [Fig. .](#)

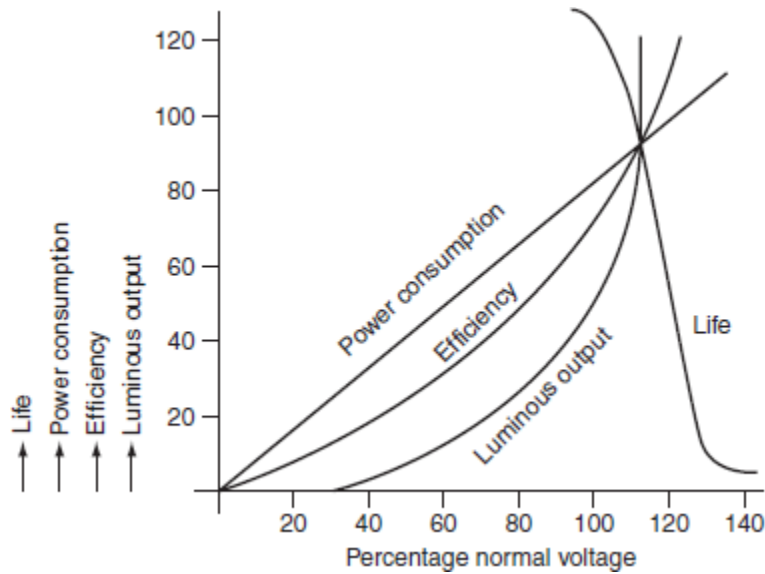

Fig Performance characteristics of incandescent lamp

With an increase in the voltage owing to the increase in the temperature, the luminous output of the incandescent lamps, and the efficiency and power consumption, but its life span decreases.

The depreciation in the light output is around 15% over the useful life of the lamp. The above-stated factors are related to the variations of voltage are given as:

- Lumens output \propto (voltage)^{3.55}.
- Power consumption \propto (voltage)^{1.55}.
- Luminous efficiency \propto (voltage)².
- Life \propto (voltage)⁻¹³ (for vacuum lamps).
- Life \propto (voltage)⁻¹⁴ (for gas filled lamps).

The advantages of the incandescent lamps

- These lamps are available in various shapes and sizes.
- These are operating at unity power factor.
- These lamps are not affected by surrounding air temperature.
- Different colored light output can be obtained by using different colored glasses.

Filament dimensions

Let us consider a lamp, which is connected to the mains, is given the steady light output, i.e., whatever the heat produced, it is dissipated and the filament temperature is not going to be

increase further. It is found to be the existence of a definite relation between the diameter of a given filament and the current through it.

The input wattage to the lamp is expressed as:

$$\begin{aligned}
 I^2 R &= I^2 \frac{\rho l}{a} && \left(\because R = \rho \frac{l}{a} \right) \\
 &= \frac{I^2 \times \rho l}{(\pi d^2 / 4)} \\
 &= I^2 \times \frac{4\rho l}{\pi d^2}, && (7.1)
 \end{aligned}$$

where I is the current taken by the lamp A , a is the filament cross-section, sq. m, ρ is the resistivity of the filament at working temperature $\Omega\text{-m}$, l is the length of the filament m, and d is the diameter of the filament.

Let the emissivity of the material be ' e '. Total heat dissipated will depend upon the surface area and the emissivity of the material

\therefore Heat dissipated \propto surface area \times emissivity:

$$\propto \pi dl \times e. \quad (7.2)$$

At the steady state condition, the power input should be equal to the heat dissipated. From Equations (7.1) and (7.2), we can write that:

$$\begin{aligned}
 I^2 \frac{4\rho l}{\pi d^2} &\propto \pi dl \times e \\
 I^2 \propto d^3 &\text{ or } I \propto d^{3/2}. && (7.3)
 \end{aligned}$$

If two filaments are made up of same material, working at same temperature and efficiency but with different diameters, then from Equation (7.3):

$$\frac{I_1}{I_2} = \left(\frac{d_1}{d_2}\right)^{3/2} \quad (7.4)$$

If two filaments are working at the same temperature, then their luminous output must be same even though their lengths are different.

$$\therefore \text{Lumen output} \propto l_1 d_1 \propto l_2 d_2$$

$$\therefore l_1 d_1 \propto l_2 d_2 = \text{constant.} \quad (7.5)$$

Limitations

The incandescent lamp suffers from the following drawbacks:

- Low efficiency.
- Colored light can be obtained by using different colored glass enclosures only.

DISCHARGE LAMPS

Discharge lamps have been developed to overcome the drawbacks of the incandescent lamp. The main principle of the operation of light in a gaseous discharge lamp is illustrated as below.

In all discharge lamps, an electric current is made to pass through a gas or vapor, which produces its illuminance. Normally, at high pressures and atmospheric conditions, all the gases are poor conductors of electricity. But on application of sufficient voltage across the two electrodes, these ionized gases produce electromagnetic radiation. In the process of producing light by gaseous conduction, the most commonly used elements are neon, sodium, and mercury. The wavelength of the electromagnetic radiation depends upon the nature of gas and the gaseous pressure used inside the lamp. A simple discharge lamp is shown in [Fig. 7.6](#).

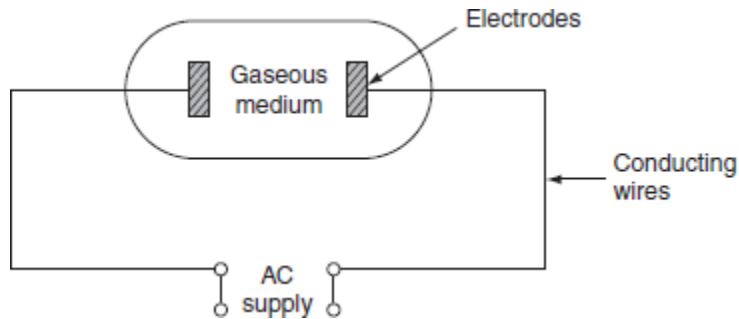

Fig. Discharge lamps

The production of light in the gaseous discharge lamps is based on the phenomenon of excitation and ionization of gas or metal vapor present between the two electrodes of a discharge tube.

When the potential between the two electrodes is equal to ionizing potential, gas or metal vapor starts ionizing and an arc is established between the two electrodes. Volt-ampere characteristics of the arc is negative, i.e., gaseous discharge lamp possess a negative resistance characteristics. A choke or ballast is provided to limit high currents to a safe value. Here, the choke serves two functions.

- It provides ignition voltage initially.
- Limits high currents.

The use of choke will reduce the power factor (0.3–0.4) of all the gaseous lamps so that all the discharge lamps should be provided with a condenser to improve the power factor. The nature of the gas and vapor used in the lamp will affect the color of light.

Types of discharge lamps

Generally used discharge lamps are of two types. They are:

1. The lamps that emit light of the color produced by discharge takes place through the gas or vapor present in the discharge tube such as neon gas, sodium vapor, mercury vapor, etc.

Ex: Neon gas, sodium vapor lamp, and mercury vapor lamp.

2. The lamp that emits light of color depends upon the type of phosphor material coated inside the walls of the discharge tube. Initially, the discharge takes place through the vapor produces UV radiation, then the invisible UV rays absorbed by the phosphors and radiates light energy falls in the visible region. This UV light causes fluorescence in certain phosphor materials, such lamps are known as fluorescent lamps.

Ex: Fluorescent mercury vapor tube.

In general, the gaseous discharge lamps are superior to the tungsten filament lamps.

Drawbacks

The discharge lamps suffer from the following drawbacks.

1. The starting of the discharge lamps requires starters and transformers; therefore, the lamp circuitry is complex.
2. High initial cost.
3. Poor power factor; therefore, the lamps make use of the capacitor.
4. Time required to give its full output brilliancy is more.
5. These lamps must be placed in particular position.
6. These lamps require stabilizing choke to limit current since the lamps have negative resistance characteristics.

NEON DISCHARGE LAMP

This is a cold cathode lamp, in which no filament is used to heat the electrode for starting.

Neon lamp consists of two electrodes placed at the two ends of a long discharge tube is shown in Fig. 7.7.

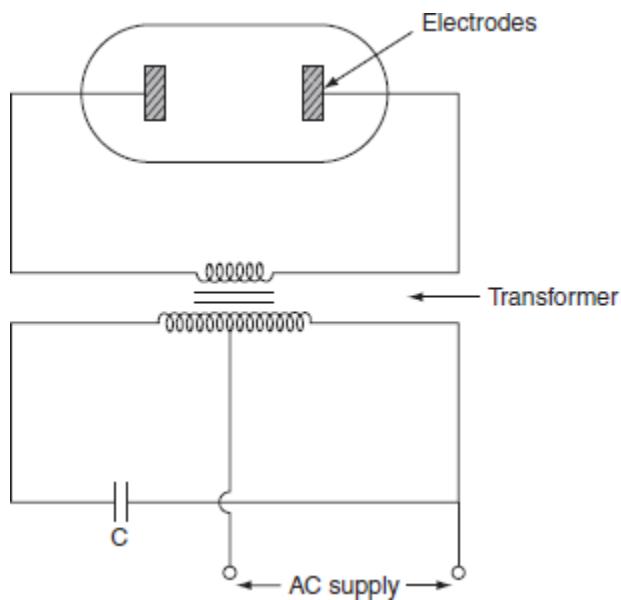

Fig. Neon lamps

The discharge tube is filled with neon gas. A low voltage of 150 V on DC or 110 V on AC is impressed across the two electrodes; the discharge takes place through the neon gas that emits light or electro magnetic radiation reddish in color. The sizes of electrodes used are equal for both AC and DC supplies. On DC, neon glow appear nearer to the negative electrode; therefore, the negative electrode is made larger in size. Neon lamp electric circuit consists of a transformer with high leakage reactance in order to stabilize the arc. Capacitor is used to improve the power factor. Neon lamp efficiency is approximately 15–40 lumens/W. The power consumption of the neon lamp is 5 W.

If the helium gas is used instead of neon, pinkish white light is obtained. These lamps are used as night lamps and as indicator lamps and used for the determination of the polarity of DC mains and for advertising purpose.

SODIUM VAPOR LAMP

A sodium vapor lamp is a cold cathode and low-pressure lamp. A sodium vapor discharge lamp consists of a *U*-shaped tube enclosed in a double-walled vacuum flask, to keep the temperature of the tube within the working region. The inner *U*-tube consists of two oxide-coated electrodes, which are sealed with the ends. These electrodes are connected to a pin type base construction of sodium vapor lamp is shown in Fig..

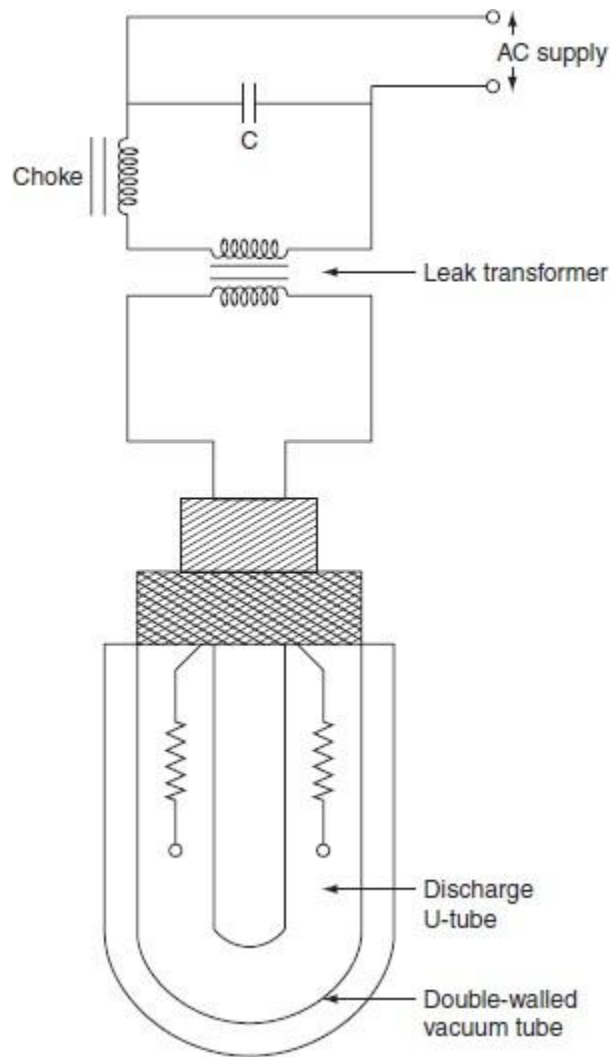

Fig. Sodium vapor lamp

This sodium vapor lamp is low luminosity lamp, so that the length of the lamp should be more. In order to get the desired length, it is made in the form of a *U*-shaped tube. This long *U*-tube consists of a small amount of neon gas and metallic sodium. At the time of start, the neon gas vaporizes and develops sufficient heat to vaporize metallic sodium in the *U*-shaped tube.

Working

Initially, the sodium is in the form of a solid, deposited on the walls of inner tube. When sufficient voltage is impressed across the electrodes, the discharge starts in the inert gas, i.e., neon; it operates as a low-pressure neon lamp with pink color. The temperature of the lamp

increases gradually and the metallic sodium vaporizes and then ionizes thereby producing the monochromatic yellow light. This lamp takes 10–15 min to give its full light output. The yellowish output of the lamp makes the object appears gray.

In order to start the lamp, 380 – 450 V of striking voltage required for 40- and 100-W lamps. These voltages can be obtained from a high reactance transformer or an auto transformer. The operating power factor of the lamp is very poor, so that a capacitor is placed to improve the power factor to above 0.8. More care should be taken while replacing the inner tube, if it is broken, then sodium comes in contact with the moisture; therefore, fire will result. The lamp must be operated horizontally or nearly so, to spread out the sodium well along the tube.

The efficiency of sodium vapor lamp is lies between 40 and 50 lumens/W. Normally, these lamps are manufactured in 45-, 60-, 85- and 140-W ratings. The normal operating temperatures of these lamps are 300°C. In general, the average life of the sodium vapor lamp is 3,000 hr and such bulbs are not affected by voltage variations.

Following are the causes of failure to operate the lamp, when:

- The cathode fails to emit the electrons.
- The filament breaks or burns out.
- All the particles of sodium are concentrated on one side of the inner tube.
- The life of the lamp increases due to aging.

The average light output of the lamp is reduced by 15% due to aging. These lamps are mainly used for highway and street lighting, parks, railway yards, general outdoor lighting, etc.

HIGH-PRESSURE MERCURY VAPOR LAMP

The working of the mercury vapor discharge lamp mainly depends upon the pressure, voltage, temperature, and other characteristics that influence the spectral quality and the efficiency of the lamp.

Generally used high-pressure mercury vapor lamps are of three types. They are:

1. MA type: Preferred for 250- and 400-W rating bulbs on 200–250-V AC supply.
2. MAT type: Preferred for 300- and 500-W rating bulbs on 200–250-V AC supply.
3. MB type: Preferred for 80- and 125-W rating bulbs and they are working at very high pressures.

MA type lamp

It is a high-pressure mercury vapor discharge lamp that is similar to the construction of sodium vapor lamp. The construction of MA type lamp is shown in [Fig. 7.9](#)

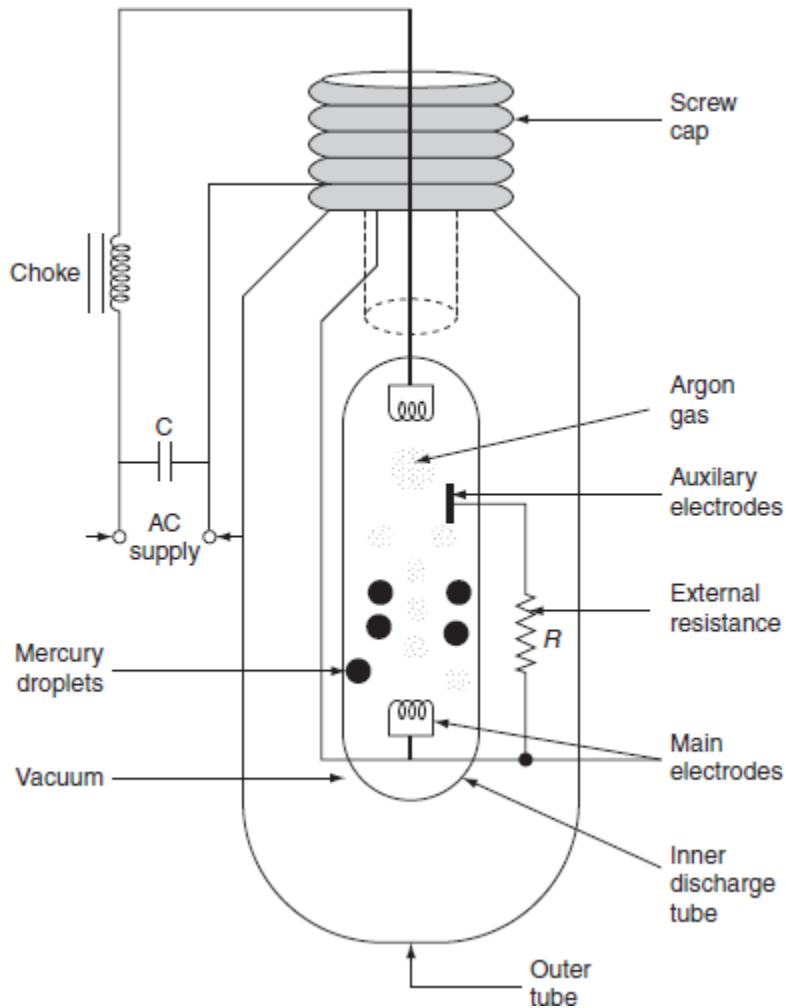

Fig. MA type lamp

MA type lamp consists of a long discharge tube in 'U' shape and is made up of hard glass or quartz. This discharge tube is enclosed in an outer tube of ordinary glass. To prevent the heat loss from the inner bulb, by convection, the gap between the two tubes is completely evacuated. The inner tube contains two main electrodes and an auxiliary starting electrode, which is connected through a high resistance of about $50 \text{ k}\Omega$. It also contains a small quantity of argon gas and mercury. The two main electrodes are tungsten coils coated with electron emitting material (such as thorium metal).

Working

Initially, the tube is cold and hence the mercury is in condensed form. Initially, when supply is given to the lamp, argon gas present between the main and the auxiliary electrodes gets

ionized, and an arc is established, and then discharge takes place through argon for few minutes between the main and the auxiliary electrodes. As a result, discharge takes place through argon for few minutes in between the main and the auxiliary electrodes. The discharge can be controlled by using high resistance that is inserted in-series with the auxiliary electrode. After few minutes, the argon gas, as a whole, gets ionized between the two main electrodes. Hence, the discharge shifts from the auxiliary electrode to the two main electrodes. During the discharge process, heat is produced and this heat is sufficient to vaporize the mercury. As a result, the pressure inside the discharge tube becomes high and the voltage drop across the two main electrodes will increase from 20 to 150 V. After 5–7 min, the lamp starts and gives its full output.

Initially, the discharge through the argon is pale blue glow and the discharge through the mercury vapors is greenish blue light; here, choke is provided to limit high currents and capacitor is to improve the power factor of the lamp.

If the supply is interrupted, the lamp must cool down and the vapor pressure be reduced before it will start. It takes approximately 3 – 4 min. The operating temperature of the inner discharge tube is about 600°C. The efficiency of this type of lamp is 30–40 lumens/W. These lamps are manufactured in 250 and 400 W ratings for use on 200–250 V on AC supply.

Generally, the MA type lamps are used for general industrial lighting, ports, shopping centers, railway yards, etc.

MAT type lamp

This is another type of mercury vapor lamp that is manufactured in 300 and 500 W rating for use on AC as well as DC supplies. The construction of the MAT type lamp is similar to the MA type lamp except the outer tube being empty; it consists of tungsten filament so that at the time of starting, it works as a tungsten filament lamp. Here, the filament itself acts as a choke or ballast to limit the high currents to safer value.

When the supply is switched on, it works as a tungsten filament lamp, its full output is given by the outer tube. At this time, the temperature of the inner discharge tube increases gradually, the argon gas present in it starts ionizing in the discharge tube at any particular temperature is attained then thermal switch gets opened, and the part of the filament is detached and voltage across the discharge tube increases. Now, the discharge takes place through the mercury vapor. Useful color effect can be obtained by this lamp. This is because of the combination of light emitted from the filament and blue radiations from the discharge tube. In this type of lamp, capacitor is not required since the overall power factor of the lamp is 0.95; this is because the filament itself acts as resistance. Fig. 7.10 shows the construction of MAT type lamp.

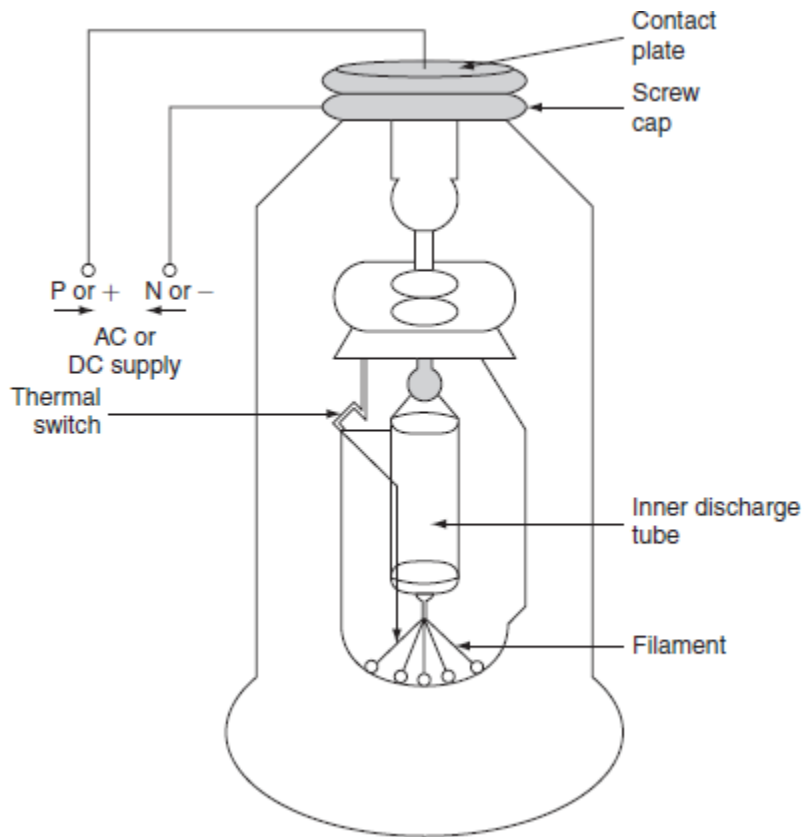

Fig. MAT type lamp

MB type lamp

Schematic representation of MB type lamp is shown in Fig. .

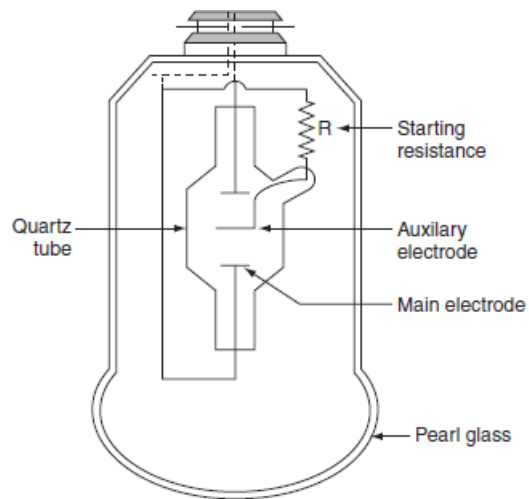

Fig. MB type lamp

The MB type lamp is also similar to the MA type lamp. The inner discharge tube for the MB type lamp is about 5 -cm long and is made up of quartz material. It has three electrodes; two main and one auxiliary electrodes. There are three electrodes present in the MB type lamp, namely two main electrodes and one auxiliary electrode. Relatively, very high pressure is maintained inside the discharge tube and it is about 5–10 times greater than atmospheric pressure. The outer tube is made with pearl glass material so as to withstand high temperatures. We can use these tubes in any position, because they are made up of special glass material.

The working principle of the MB type lamp is similar to the MA type lamp. These lamps are manufactured in 300 and 500 W rating for use in AC as well as DC supplies. An MB type lamp consists a bayonet cap with three pins, so it may not be used in an ordinary sense. A choke coil and a capacitor are necessary for working with these types of lamps.

FLUORESCENT LAMP (LOW-PRESSURE MERCURY VAPOR LAMP)

Fluorescent lamp is a hot cathode low-pressure mercury vapor lamp; the construction and working of the fluorescent lamp are explained as follows.

Construction

It consists of a long horizontal tube, due to low pressure maintained inside of the bulb; it is made in the form of a long tube.

The tube consists of two spiral tungsten electrode coated with electron emissive material and are placed at the two edges of long tube. The tube contains small quantity of argon gas and certain amount of mercury, at a pressure of 2.5 mm of mercury. The construction of fluorescent lamp is shown in [Fig. 7.12](#). Normally, low-pressure mercury vapor lamps suffer from low efficiency and they produce an objectionable colored light. Such drawback is overcome by coating the inside of the tube with fluorescent powders. They are in the form of solids, which are usually known as phosphors.

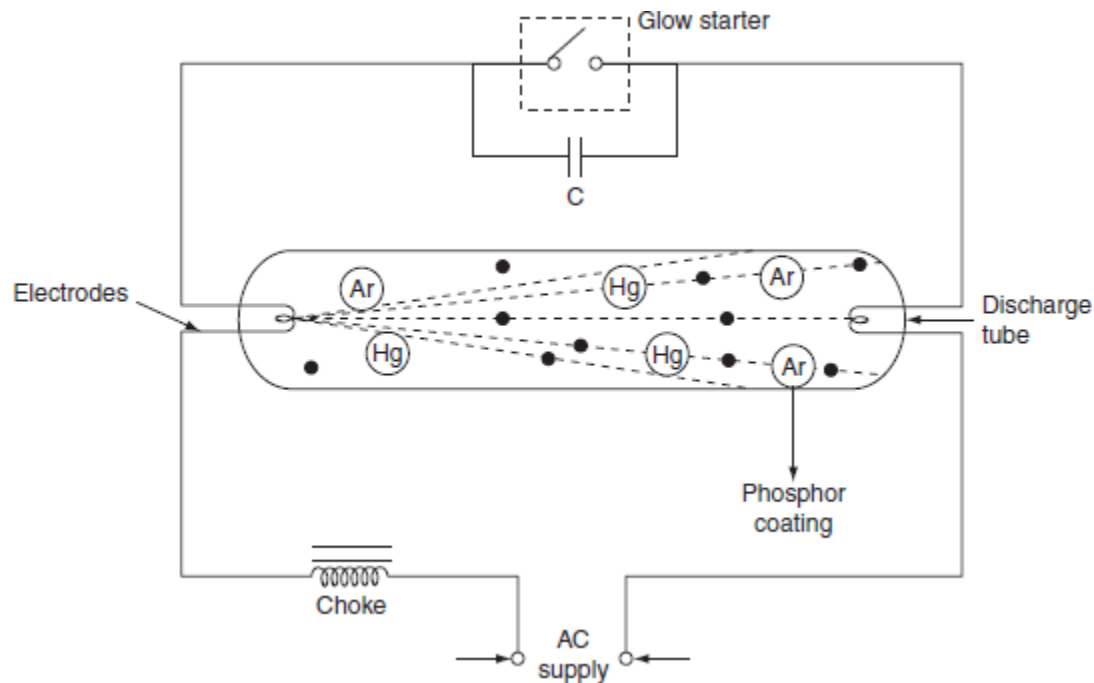

Fig. Fluorescent lamp

A glow starter switch contains small quantity of argon gas, having a small cathode glow lamp with bimetallic strip is connected in series with the electrodes, which puts the electrodes directly across the supply at the time of starting. A choke is connected in series that acts as ballast when the lamp is running, and it provides a voltage impulse for starting. A capacitor of $4\mu\text{F}$ is connected across the starter in order to improve the power factor.

Working

At the time of starting, when both the lamp and the glow starters are cold, the mercury is in the form of globules. When supply is switched on, the glow starter terminals are open circuited and full supply voltage appeared across these terminals, due to low resistance of electrodes and choke coil. The small quantity of argon gas gets ionized, which establishes an arc with a starting glow. This glow warms up the bimetallic strip thus glow starts gets short circuited. Hence, the two electrodes come in series and are connected across the supply voltage. Now, the two electrodes get heated and start emitting electrons due to the flow of current through them. These electrons collide with the argon atoms present in the long tube discharge that takes place through the argon gas. So, in the beginning, the lamp starts conduction with argon gas as the temperature increases, the mercury changes into vapor form and takes over the conduction of current.

In the mean time, the starter potential reaches to zero and the bimetallic strip gets cooling down. As a result, the starter terminals will open. This results breaking of the series circuit. A

very high voltage around 1,000 V is induced, because of the sudden opening of starter terminals in the series circuit. But in the long tube, electrons are already present; this induced voltage is quite sufficient to break down the long gap. Thus, more number of electrons collide with argon and mercury vapor atoms. The excited atom of mercury gives UV radiation, which will not fall in the visible region.

Meanwhile, these UV rays are made to strike phosphor material; it causes the re-emission of light of different wavelengths producing illumination. The phenomenon of the emission is called as *luminescence*.

This luminescence is classified into two ways. They are:

1. **Fluorescence:** In this case, the excitation presents for the excited periods only.
2. **Phosphorescence:** In this case, even after the exciting source is removed, the excitation will present.

In a lamp, the re-emission of light causes fluorescence, then such lamp is known as *fluorescent lamp*.

Depending upon the type of phosphor material used, we get light of different colors as given in Table.

Table Colors of light

	<i>Phosphor material</i>	<i>Color effect</i>
1.	Zinc silicate	Green
2.	Calcium tungstate	Green
3.	Magnesium tungstate	Bluish white
4.	Cadmium silicate	Yellowish pink
5.	Zinc beryllium silicate	Yellowish white
6.	Cadmium borate	Pink

Advantages of fluorescent lamp

The fluorescent lamp has the following advantages:

- High efficiency.
- The life of the lamp is three times of the ordinary filament lamp.

- The quality of the light obtained is much superior.
- Less chances of glare.
- These lamps can be mounted on low ceiling, where other light sources would be unsatisfactory.

Although the fluorescent lamp has the above advantages, it suffers from the following disadvantages:

- The initial cost is high because of choke and starter.
- The starting time as well as the light output of the lamp will increase because of low ambient temperature.
- Because of the presence of choke, these lamps suffer from magnetic humming and may cause disturbance.
- The stroboscopic effect of this lamp is objectionable.

Stroboscopic effect

We all know that because of 'the alternating nature of supply, it crosses zero two times in a cycle'. For 50-Hz frequency supply of the alternating current, a discharge lamp will be extinguished twice in a cycle and 100 times per second (for 50-Hz supply). A human eye cannot identify this extinguish phenomenon, because of the persistence of vision. If this light falls upon a moving object, the object appearing like slow moving or fast moving or moving in reverse direction, sometimes stationary. This effect is due to the extinguishing nature of the light of the lamp. This effect is called as '*stroboscopic effect*'.

This effect can be avoided by employing any of the two techniques listed below.

1. If we have three-phase supply, then the fluorescent lamps that are adjacent should be fed from different phases. Then, no two lamps will not be in same phase at zero instant of AC supply, so light is present at any instant.
2. If the available supply is single phase, then twin tube circuitry as shown in [Fig. 7.13](#), we can eliminate stroboscopic effect.

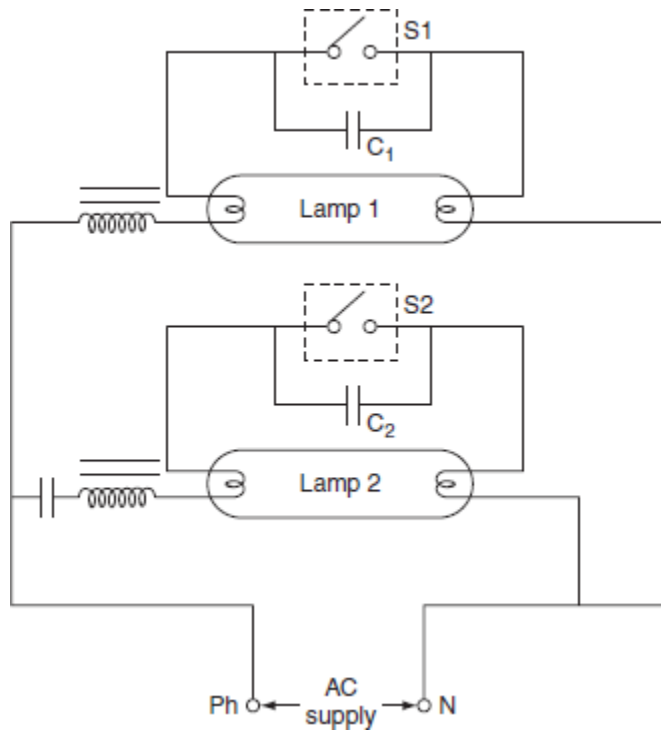

Fig. Lead-lag circuit

Twin tube circuit is also known as *lead-lag circuit*. Here two tubes are connected in parallel. One of the two tubes provided with a capacitor in series with the choke coil. The current through the lamps is almost 90° out of phase and under these conditions, the light output of one of the lamps is at maximum. Moreover, the overall power factor of lamps is unity. In this lead-lag arrangement, one of the lamps is operating at 0.5 lagging, the other, provided with capacitor, is operating at 0.5 leading.

In general, the life of a fluorescent lamp is about 7,500 hr. Based on the operating conditions, the lamp's actual life can be varied from 5,000 to 10,000 hr. It is recommended to replace a lamp after 4,000–5,000 of its working hours.

COMPARISON BETWEEN TUNGSTEN FILAMENT LAMPS AND FLUORESCENT LAMPS

<i>Incandescent lamp</i>	<i>Fluorescent lamp</i>
1. Initial cost is less.	1. Initial cost is more.
2. Fluctuation in supply voltage has less effect on light output, as the variations in voltage are absorbed in choke.	2. Fluctuations in supply voltage has comparatively more effect on the light output.

<i>Incandescent lamp</i>	<i>Fluorescent lamp</i>
3. It radiates the light; the color of which resembles the natural light.	3. It does not give light close to the natural light.
4. It works on AC as well as DC.	4. Change of supply needs additional equipment.
5. The luminous efficiency of the lamp is high that is about 8 – 40 lumens/W.	5. The luminous efficiency is poor, which is about 8–10 lumen/W.
6. Different color lights can be obtained by using different colored glasses.	6. Different color lights can be obtained by using different composition of fluorescent powder.
7. Brightness of the lamp is more.	7. Brightness of the lamp is less.
8. The reduction in light output of the lamp is comparatively high, with the time.	8. The reduction in light output of the lamp is comparatively low, with the lamp.
9. The working temperature is about 2,000°C.	9. The working temperature is about 50°C.
10. The normal working life is 1,000 hr.	10. The normal working life is 5,000–7,500 hr.
11. No stroboscopic effect.	11. Stroboscopic effect is present.
12. These lamps are widely used for domestic, industrial, and street lighting.	12. They find wide application in domestic, industrial, and floodlighting.
13. The luminous efficiency increases with the increase in the voltage of the lamp.	13. The luminous efficiency increase with the increase in voltage and the increase in the length of tube.

BASIC PRINCIPLES OF LIGHT CONTROL

When light strikes the surface of an object, based on the properties of that surface, some portion of the light is reflected, some portion is transmitted through the medium of the surface, and the remaining is absorbed.

The method of light control is used to change the direction of light through large angle. There are four light control methods. They are:

1. reflection,
2. refraction,
3. rdiffusion, and
4. absorption.

Reflection

The light falling on the surface, whole of the light will not absorbed or transmitted through the surface, but some of the light is reflected back, at an angle equals to the angle of incidence. The ratio of reflected light energy to the incident light energy is known as reflection factor. The two basic types of reflection are:

1. mirror or specular reflection and
2. diffuse reflection.

Specular reflection

When whole of the light falling on a smooth surfaces will be reflected back at an angle equal to the angle of incidence. Such a reflection is known as *specular reflection*. With such reflection, observer will be able to see the light source but not the illuminated surface. Most of the surfaces causing the specular reflection are silvered mirrors, highly polished metal surfaces. Specular reflection is shown in [Fig. 7.17](#).

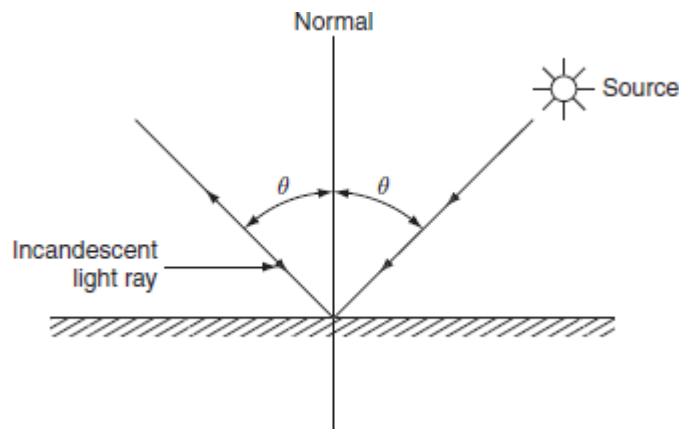

Fig. 7.17 Specular reflection

A surface that is almost free from reflection is called a matt surface.

Diffuse reflection

When the light ray falling on any surface, it is scattered in all directions irrespective of the angle of incidence. Such type of reflector is known as *diffuse reflection* and is shown in [Fig. 7.18](#). Most

of the surfaces causing the diffuse reflection are rough or matt surfaces such as blotting paper, frosted glass, plaster, etc.

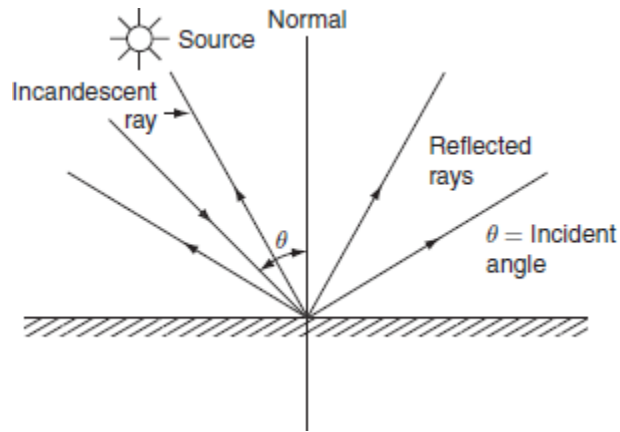

Fig. 7.18 Diffuse reflection

In this reflection, observer will be able to see the illuminated surface but not the light source.

Refraction

When a beam of light passes through two different mediums having different densities, the light ray will be refracted. This phenomenon is known as *refraction*.

Figure 7.19 shows the refraction of light ray from dense medium to rare medium where μ_1 and μ_2 are the refractive indices of two mediums, θ is the angle of incidence, and α is the angle of refraction.

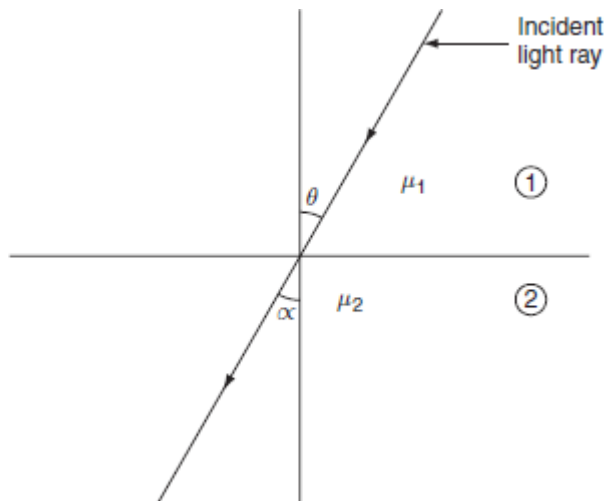

Fig. 7.19 Refraction

The angle of light ray with normal is comparatively less in dense medium than in rare medium.

Diffusion

When a ray of light falling on a surface is reflected in all possible directions, so that such surface appears luminous from all possible directions. This can be achieved with a diffusing glass screen introduced between the observer and the light source. The normally employed diffusing glasses are opal glass and frosted glass. Both are ordinary glasses, but frosted glass is an ordinary glass coated with crystalline substance.

Although frosted glass is cheaper than opal glass, the disadvantage of frosted glass is, it collects more dust particles and it is difficult to clean.

Absorption

In some of the cases, whole of the light emitted by tungsten filament lamp will be excessive, so that it is necessary to avoid that the amount of unwanted wavelengths without interference. This can be achieved by using a special bluish colored glass for the filament lamp to absorb the unwanted radiation.

TYPES OF LIGHTING SCHEMES

Usually, with the reflector and some special diffusing screens, it is possible to control the distribution of light emitted from lamps up to some extent. A good lighting scheme results in an attractive and commanding presence of objects and enhances the architectural style of the interior of a building. Depending upon the requirements and the way of light reaching the surface, lighting schemes are classified as follows:

1. direct lighting,
2. semidirect lighting,
3. indirect lighting,
4. semi-indirect lighting, and
5. general lighting.

Direct lighting schemes

Direct lighting scheme is most widely used for interior lighting scheme. In this scheme, by using deep reflectors, it is possible to make 90% of light falls just below the lamp. This scheme is more efficient but it suffers from hard shadows and glare. Hence, while designing such schemes, all the possibilities that will cause glare on the eye have to be eliminated. It is mainly used for industrial and general outdoor lighting.

Semidirect lighting schemes

In semidirect lighting scheme, about 60–90% of lamps luminous flux is made to fall downward directly by using some reflectors and the rest of the light is used to illuminate the walls and ceiling. This type of light scheme is employed in rooms with high ceiling. Glare can be avoided by employing diffusing globes. This scheme will improve not only the brightness but also the efficiency.

Indirect lighting schemes

In this lighting scheme, 90% of total light is thrown upwards to the ceiling. In such scheme, the ceiling acts as the lighting source and glare is reduced to minimum.

This system provides shadowless illumination, which is very useful for drawing offices and in workshops where large machines and other difficulties would cause trouble some shadows if direct lighting schemes were used.

Semi-indirect lighting schemes

In semi-indirect lighting scheme, about 60–90% of light from the lamp is thrown upwards to the ceiling and the remaining luminous flux reaches the working surface. Glare will be completely

eliminated with such type of lighting scheme. This scheme is widely preferred for indoor lighting decoration purpose.

General lighting scheme

This scheme of lighting use diffusing glasses to produce the equal illumination in all directions. Mounting height of the source should be much above eye level to avoid glare. Lamp fittings of various lighting schemes are shown in [Fig. 7.20](#).

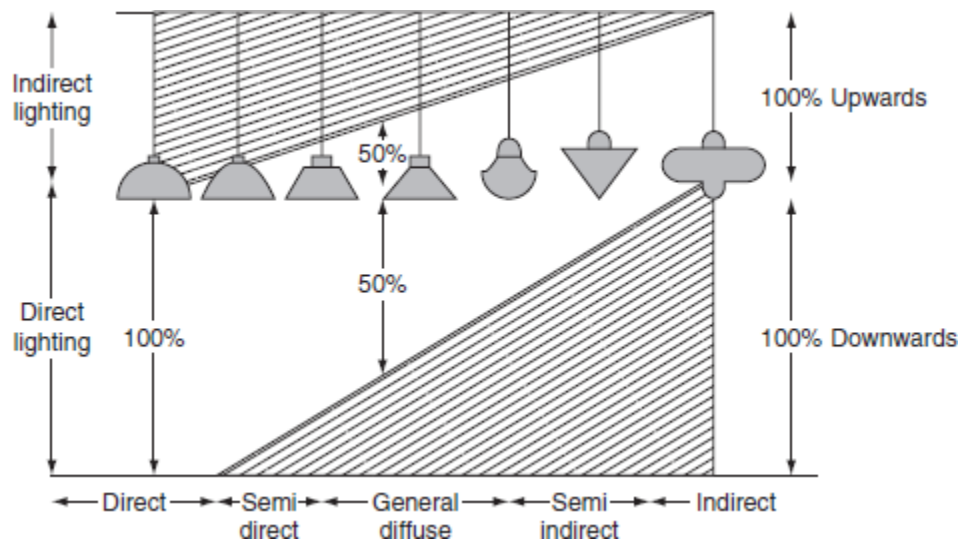

Fig. 7.20 Lighting schemes

DESIGN OF LIGHTING SCHEMES

The lighting scheme should be such that:

- It should be able to provide sufficient illumination.
- It should be able to provide the uniform distribution of light throughout the working plane.
- It should be able to produce the light of suitable color.
- It should be able to avoid glare and hard shadows as much as possible.

While designing a lighting scheme, the following factors should be taken into consideration.

1. Illumination level.
2. The size of the room.
3. The mounting height and the space of fitting.

STREET LIGHTING

Street lighting not only requires for shopping centers, promenades, etc. but also necessary for the following.

- In order to make the street more attractive, so that obstructions on the road clearly visible to the drivers of vehicles.
- To increase the community value of the street.
- To clear the traffic easily in order to promote safety and convenience.

The basic principles employed for the street lighting are given below.

1. Diffusion principle.
2. The specular reflection principle.

Diffusion principle

In this method, light is directed downwards from the lamp by the suitably designed reflectors. The design of these reflectors are in such a way that they may reflect total light over the road surface uniformly as much as possible. The reflectors are made to have a cutoff between 30° and 45° , so that the filament of the lamp is not visible except just below the source, which results in eliminating glare. Illumination at any point on the road surface is calculated by applying inverse square law or point-by-point method.

Specular reflection principle

The specular reflection principle enables a motorist to see an object about 30 m ahead. In this case, the reflectors are curved upwards, so that the light is thrown on the road at a very large angle of incidence. This can be explained with the help of [Fig. 7.21](#). An object resides over the road at 'P' in between the lamps S_1 , S_2 , and S_3 and the observer at 'Q'.

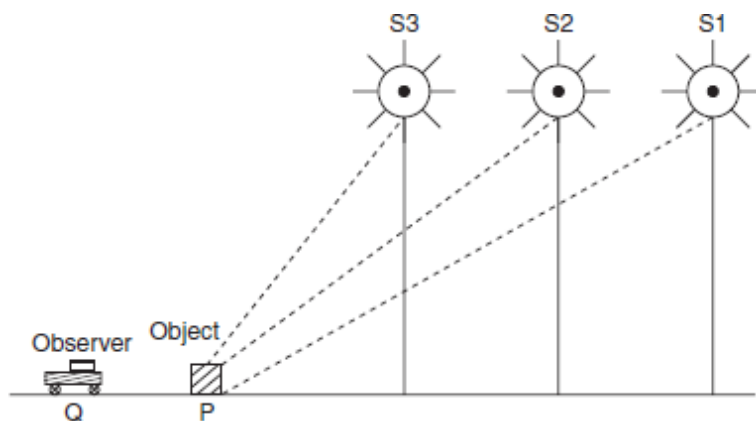

Fig. 7.21 Specular reflection for street lighting

Thus, the object will appear immediately against the bright road surface due to the lamps at a longer distance. This method of lighting is only suitable for straight sections along the road. In this method, it is observed that the objects on the roadway can be seen by a smaller expenditure of power than by the diffusion method of lighting.

Illumination level, mounting height, and the types of lamps for street lighting

Normally, illumination required depends upon the class of street lighting installation. The illumination required for different areas of street lighting are given in [Table 7.3](#).

Table 7.3 Illumination required for different areas of street lighting

	Area	Illumination (lumen/m²)
1.	Road junctions and important shopping centers.	30
2.	Poorly lighted sub-urban streets.	4
3.	Average well-lighted street.	8–15

Mercury vapor and sodium vapor discharge lamps are preferable for street lighting since the overall cost of the installation of discharge lamps are less than the filament lamps and also the less power consumption for a given amount of power output. Normal spacing for the standard lamps is 50 m with a mounting height of 8 m. Lamp posts should be fixed at the junctions of roads.

FLOODLIGHTING

Floodlighting means flooding of large surface areas with light from powerful projectors. A special reflector and housing is employed in floodlighting in order to concentrate the light emitted from the lamp into a relatively narrow beam, which is known as floodlight projector. This projector consists of a reflecting surface that may be a silvered glass or chromium plate or stainless steel. The efficiency of silvered glass and polished metal are 85–90% and 70%, respectively. Usually metal reflectors are robust; therefore, they can be preferred. An important application of illumination engineering is the floodlighting of large and open areas. It is necessary to employ floodlighting to serve one or more of the following purposes.

METHODS OF LIGHTING CALCULATIONS

There are so many methods have been employed for lighting calculation, some of those methods are as follows.

1. Watts-per-square-meter method.
2. Lumen or light flux method
3. Point-to-point method

Example 7.1: A room 20×10 m is illuminated by 60 W incandescent lamps of lumen output of 1,600 lumens. The average illumination required at the workplace is 300 lux. Calculate the number of lamps required to be fitted in the room. Assume utilization and depreciation factors as 0.5 and 1, respectively.

Solution:

The area of the room (A) = 20×10 m
= 200 m².

Total illumination required (E) = 300 lux.

The wattage of each lamp = 60 W

The luminous output of the lamp (ϕ) = 1,600 lumens

UF = 0.5, DF = 1.

\therefore Maintenance factor, $MF = \frac{1}{DF} = \frac{1}{1} = 1.$

\therefore The number of lamps required:

$$N = \frac{F \times A}{\phi \times UF \times MF}$$
$$= \frac{300 \times 200}{1,600 \times 1 \times 0.5} = 7.5 \text{ lamps.}$$

Example 7.2: The front of a building 35×18 m is illuminated by 15 lamps; the wattage of each lamp is 80 W. The lamps are arranged so that uniform illumination on the surface is obtained. Assuming a luminous efficiency of 20 lumens/W, the coefficient of utilization is 0.8, the waste light factor is 1.25, DF = 0.9. Determine the illumination on the surface.

Solution:

$$\text{Area} = (A) = 35 \times 18 = 630 \text{ m}^2.$$

The number of lamps, $N = 15$.

Luminous efficiency, $\eta = 20$ lumens/W.

UF = 0.8, DF = 0.9.

Waste light factor = 1.25, $E = ?$

$$\therefore N = \frac{A \times E \times DF \times \text{waste light factor}}{UF \times \eta \times \text{wattage of each lamp}}$$

$$15 = \frac{630 \times E \times 1.25 \times 0.9}{0.8 \times 20 \times 80}$$

$$= 0.554 E.$$

$$\therefore E = 27.07 \text{ lux (or) lumens/m}^2.$$

Example 7.3: A room of size 10×4 m is to be illuminated by ten 150-W lamps. The MSCP of each lamp is 300. Assuming a depreciation factor of 0.8 and a utilization factor of 0.5. Find the average illumination produced on the floor.

Solution:

The area of the room $(A) = 10 \times 4 = 40 \text{ m}^2$.

The total luminous flux emitted by ten lamps (ϕ)

$$= 10 \times 150 \times 4\pi = 18,849.5 \text{ lumens.}$$

The total luminous flux reaching the working plane

$$\begin{aligned}
&= \frac{\phi \times \text{utilization factor}}{\text{depreciation factor}} \\
&= \frac{18,849.5 \times 0.5}{0.8} = 11,780.97 \text{ lumens.}
\end{aligned}$$

The illumination on the working plane

$$\begin{aligned}
E &= \frac{\text{lumens on the working plane}}{\text{total area to be illuminated}} \\
&= \frac{11,780.97}{40} = 294.52 \text{ lux.}
\end{aligned}$$

Example 7.4: The front of a building 25×12 m is illuminated by 20 1,200-W lamps arranged so that uniform illumination on the surface is obtained. Assuming a luminous efficiency of 30 lumens/W and a coefficient of utilization of 0.75. Determine the illumination on the surface. Assume DF = 1.3 and waste light factor 1.2.

Solution:

$$\text{Area to be illuminated} = 25 \times 12 = 300 \text{ m}^2.$$

The total lumens given out by 20 lamps is:

$$\begin{aligned}
\phi &= \text{number of lamps} \times \text{wattage of each lamp} \times \text{efficiency of each lamp} \\
&= 20 \times 30 \times 1,200 = 720,000 \text{ lumens.}
\end{aligned}$$

The total lumens reaching the surface to be illuminated

$$\begin{aligned}
&= \frac{\phi \times UF}{DF \times \text{waste light factor}} \\
&= \frac{7,20,000 \times 0.75}{1.3 \times 1.2} \\
&= 3,46,153.84 \text{ lumens.}
\end{aligned}$$

The illumination on the surface:

$$E = \frac{3,46,153.84}{300} = 1,153.84 \text{ lux.}$$

Example 7.5: An illumination of 40 lux is to be produced on the floor of a room 16×12 m. 15 lamps are required to produce this illumination in the room; 40% of the emitted light falls on the floor. Determine the power of the lamp in candela. Assume maintenance factor as unity.

Solution:

Given data

$$E = 40 \text{ lux}$$

$$A = 16 \times 12 = 192 \text{ m}^2$$

$$\text{Number of lamps, } N = 15$$

$$\text{UF} = 0.4, \text{ MF} = 1$$

$$N = \frac{E \times A}{\phi \times \text{UF} \times \text{MF}}$$

$$15 = \frac{40 \times 192}{\phi \times 0.4 \times 1}$$

$$\therefore \phi = 1,280 \text{ lux.}$$

$$\text{So, the lumen output of the lamp in candela} = \frac{1,280}{4\pi} = 101.85 \text{ cd.}$$

Example 7.6: A drawing, with an area of 18×12 m, is to be illuminated with an average illumination of about 150 lux. The lamps are to be fitted at 6 m height. Find out the number and size of incandescent lamps required for an efficiency of 20 lumens/W. UF = 0.6, MF = 0.75.

Solution:

Given data:

$$\eta = 20 \text{ lumens/W}$$

$$E = 150 \text{ lux}$$

$$A = 18 \times 12 = 216 \text{ m}^2$$

$$\text{UF} = 0.6$$

$$MF = 0.75$$

The total gross lumens required $\phi = \frac{E \times A}{UF \times MF}$.

$$= \frac{150 \times 216}{0.6 \times 0.75} = 72,000 \text{ lumens.}$$

The total wattage required $= \frac{72,000}{\eta}$

$$= \frac{72,000}{20} = 3,600 \text{ W.}$$

Let, if 24 lamps are arranged to illuminate the desired area. For space to height ratio unity, i.e., 6 lamps are taken along the length with a space of $18/6 = 3\text{m}$, and 4 lamps are along the width giving a space of $12/4 = 3\text{m}$.

\therefore The wattage of each lamp $= \frac{3,600}{24} = 150 \text{ W.}$

The arrangement of 24 lamps in a hall of $18 \times 12\text{ m}$ is shown in [Fig. P.7.1](#)

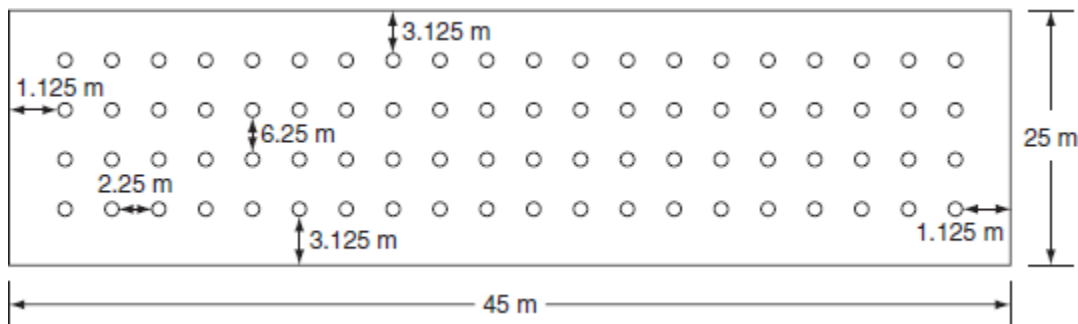

Fig. P.7.1 Lamp arrangement

Example 7.7: A hall of 30×20 m area with a ceiling height of 6 m is to be provided with a general illumination of 200 lumens/m^2 , taking a coefficient of utilization of 0.6 and depreciation factor of 1.6. Determine the number of fluorescent tubes required, their spacing, mounting height, and total wattage. Take luminous efficiency of fluorescent tube as 25 lumens/W for 300-W tube.

Solution:

Given data:

$$\text{Area of hall (A)} = 30 \times 20 \text{ m} = 600 \text{ m}^2$$

$$E = 200 \text{ lumens/m}^2$$

$$\text{CU} = 0.6$$

$$\text{DF} = 1.6$$

The wattage of fluorescent tube = 300 W

Efficiency $\eta = 25 \text{ lumens/W}$

$$\begin{aligned} \therefore \text{Gross lumens required, } \phi &= \frac{A \times E \times \text{DF}}{\text{CU}} \\ &= \frac{600 \times 200 \times 1.6}{0.6} = 320,000 \text{ lux.} \end{aligned}$$

$$\text{The total wattage required} = \frac{\phi}{\eta} = \frac{320,000}{25}$$

$$\begin{aligned} \text{The number of tubes required} &= \frac{\text{total wattage required}}{\text{wattage of each tube}} \\ &= \frac{12,800}{300} \\ &= 42.666 \cong 44. \end{aligned}$$

Let us arrange 44 lamps in a 30×30 m hall, by taking 11 lamps along the length with spacing $30/11 = 2.727$ m and 4 lamps along the width with spacing $20/4 = 5$ m. Here the space to height ratio with this arrangement is, $2.727/5 = 0.545$. Disposition of lamps is shown in Fig. P.7.2.

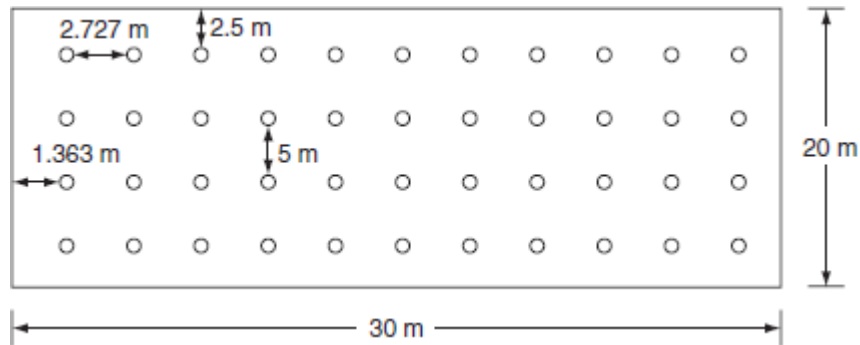

Fig. P.7.2 Lamp arrangement

Example 7.8: A hall 40-m long and 16-m wide is to be illuminated and illumination required is 70-m candles. Five types of lamps having lumen outputs, as given below are available.

Watts:	50	100	150	200	250
Lumens:	1,500	1,830	2,500	3,200	4,000

Taking a depreciation factor of 1.5 and a utilization coefficient of 0.7, calculate the number of lamps required in each case to produce required illumination. Out of above five types of lamps, select most suitable type and design, a suitable scheme, and make a sketch showing location of lamps. Assume a suitable mounting height and calculate space to height ratio of lamps.

Solution:

Given data:

$$\text{Area (A)} = 30 \times 12 = 360 \text{ m}^2$$

$$\text{DF} = 1.5$$

$$\text{CU} = 0.7$$

$$E = 50\text{-m candle}$$

Total gross lumens required:

$$\phi = \frac{A \times E \times DF}{UF}$$

$$= \frac{360 \times 50 \times 1.5}{0.7} = 38,572.42 \text{ lumens.}$$

- | | | |
|----|---|---|
| 1. | If 50-W lamps are used, the number of lamps required | $= \frac{38,571.42}{1,500} = 25.7 \cong 26.$ |
| 2. | If 100-W lamps are used, the number of lamps required | $= \frac{38,571.42}{1,830} = 7.416 \cong 8.$ |
| 3. | If 150-W lamps are used, the number of lamps required | $= \frac{38,571.42}{2,500} = 15.42 \cong 16.$ |
| 4. | If 200-W lamps are used, the number of lamps required | $= \frac{38,571.42}{3,200} = 12.05 \cong 14.$ |
| 5. | If 250-W lamps are used, the number of lamps required | $= \frac{38,571.42}{4,000} = 9.642 \cong 10.$ |

Suitable type of lamp fitting will be 250-W lamps for a hall of 40×16 m.

Here, 10 lamps are arranged in two rows, each row having 5 lamps. By taking 5 lamps along the length with spacing $40/8=5$ m and 2 lamps along width side with spacing $16/2 = 8$ m, i.e., space to height ratio = $8/8 = 1$.

The disposition of lamps is shown in [Fig. P.7.3](#).

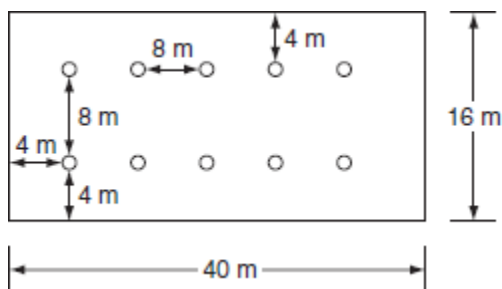

Fig. Lamp arrangement

Among the other lamps, some of wattage lamps require more number of lamp fittings and some other lamps will be few in requirement giving space–height ratio much more than re

UNIT 4

Electric Traction - I

INTRODUCTION

The system that causes the propulsion of a vehicle in which that driving force or tractive force is obtained from various devices such as electric motors, steam engine drives, diesel engine drives, etc. is known as traction system.

Traction system may be broadly classified into two types. They are electric-traction systems, which use electrical energy, and non-electric traction system, which does not use electrical energy for the propulsion of vehicle.

Requirements of ideal traction system

Normally, no single traction system fulfills the requirements of ideal traction system, why because each traction system has its merits and suffers from its own demerits, in the fields of applications.

The requirements of ideal traction systems are:

- Ideal traction system should have the capability of developing high tractive effort in order to have rapid acceleration.
- The speed control of the traction motors should be easy.
- Vehicles should be able to run on any route, without interruption.
- Equipment required for traction system should be minimum with high efficiency.
- It must be free from smoke, ash, dirt, etc.
- Regenerative braking should be possible and braking should be in such a way to cause minimum wear on the break shoe.
- Locomotive should be self-contained and it must be capable of withstanding overloads.
- Interference to the communication lines should be eliminated while the locomotive running along the track.

Advantages and Disadvantages of Electric Traction

Electric traction system has many advantages compared to non-electric traction systems. The following are the advantages of electric traction:

- Electric traction system is more clean and easy to handle.

- No need of storage of coal and water that in turn reduces the maintenance cost as well as the saving of high-grade coal.
- Electric energy drawn from the supply distribution system is sufficient to maintain the common necessities of locomotives such as fans and lights; therefore, there is no need of providing additional generators.
- The maintenance and running costs are comparatively low.
- The speed control of the electric motor is easy.
- Regenerative braking is possible so that the energy can be fed back to the supply system during the braking period.
- In electric traction system, in addition to the mechanical braking, electrical braking can also be used that reduces the wear on the brake shoes, wheels, etc.
- Electrically operated vehicles can withstand for overloads, as the system is capable of drawing more energy from the system.

In addition to the above advantages, the electric traction system suffers from the following drawbacks:

- Electric traction system involves high erection cost of power system.
- Interference causes to the communication lines due to the overhead distribution networks.
- The failure of power supply brings whole traction system to stand still.
- In an electric traction system, the electrically operated vehicles have to move only on the electrified routes.
- Additional equipment should be needed for the provision of regenerative braking, it will increase the overall cost of installation.

REVIEW OF EXISTING ELECTRIC TRACTION SYSTEM IN INDIA

In olden days, first traction system was introduced by Britain in 1890 (600-V DC track). Electrification system was employed for the first traction vehicle. This traction system was introduced in India in the year 1925 and the first traction system employed in India was from Bombay VT to Igatpuri and Pune, with 1,500-V DC supply. This DC supply can be obtained for traction from substations equipped with rotary converters. Development in the rectifiers leads to the replacement of rotary converters by mercury arc rectifiers. But nowadays further development in the technology of semiconductors, these mercury arc valves are replaced by solid-state semiconductors devices due to fast traction system was introduced on 3,000-V DC. Further development in research on traction system by French international railways was suggested that, based on relative merits and

demerits, it is advantageous to prefer to AC rather than DC both financially and operationally.

Thus, Indian railways was introduced on 52-kV, 50-Hz single-phase AC system in 1957; this system of track electrification leads to the reduction of the cost of overhead, locomotive equipment, etc. Various systems employed for track electrification are shown in Table .

Table Track electrification systems

S. no	System	Voltage	Frequency
1	DC system	600 V, 1,500 V, or 3,000 V	–
2	Single-phase AC system	15–25 kV is stepped down to 300–400 V	$\frac{162}{3}$ Hz and 25 Hz
3	Three-phase AC system	15–25 kV is stepped down to 3,300–3,600 V	$\frac{162}{3}$ Hz and 50 Hz

SYSTEM OF TRACTION

Traction system is normally classified into two types based on the type of energy given as input to drive the system and they are:

1. Non-electric traction system

Traction system develops the necessary propelling torque, which do not involve the use of electrical energy at any stage to drive the traction vehicle known as electric traction system.

Ex: Direct steam engine drive and direct internal combustion engine drive.

2. Electric traction system

Traction system develops the necessary propelling torque, which involves the use of electrical energy at any stage to drive the traction vehicle, known as electric traction system.

Based upon the type of sources used to feed electric supply for traction system, electric traction may be classified into two groups:

1. Self-contained locomotives.
2. Electric vehicle fed from the distribution networks.

Self-contained locomotives

In this type, the locomotives or vehicles themselves having a capability of generating electrical energy for traction purpose. Examples for such type of locomotives are:

1. Steam electric drive

In steam electric locomotives, the steam turbine is employed for driving a generator used to feed the electric motors. Such types of locomotives are not generally used for traction because of some mechanical difficulties and maintenance problems.

2. Diesel electric trains

A few locomotives employing diesel engine coupled to DC generator used to feed the electric motors producing necessary propelling torque. Diesel engine is a variable high-speed type that feeds the self- or separately excited DC generator. The excitation for generator can be supplied from any auxiliary devices and battery.

Generally, this type of traction system is suggested in the areas where coal and steam tractions are not available. The advantages and disadvantages of the diesel engine drive are given below:

Advantages

- As these are no overhead distribution system, initial cost is low.
- Easy speed control is possible.
- Power loss in speed control is very low
- Time taken to bring the locomotive into service is less.
- In this system, high acceleration and braking retardation can be obtained compared to steam locomotives.
- The overall efficiency is high compared to steam locomotives.

Disadvantages

- The overloading capability of the diesel engine is less.
- The running and maintenance costs are high.
- The regenerative braking cannot be employed for the diesel engine drives.

Petrol electric traction

This system of traction is used in road vehicles such as heavy lorries and buses. These vehicles are capable of handling overloads. At the same time, this system

provides fine and smooth control so that they can run along roads without any jerking.

Battery drives

In this drive, the locomotive consists of batteries used to supply power to DC motors employed for driving the vehicle. This type of drives can be preferred for frequently operated services such as local delivery goods traction in industrial works and mines, etc. This is due to the unreliability of supply source to feed the electric motors.

Electric vehicles fed from distribution network

Vehicles in electrical traction system that receives power from over head distribution network fed or substations with suitable spacing. Based on the available supply, these groups of vehicles are further subdivided into:

1. System operating with DC supply. Ex: tramways, trolley buses, and railways.
2. System operating with AC supply. Ex: railways.

Systems operating with DC supply

In case if the available supply is DC, then the necessary propelling power can be obtained for the vehicles from DC system such as tram ways, trolley buses, and railways.

Tramways: Tramways are similar to the ordinary buses and cars but only the difference is they are able to run only along the track. Operating power supply for the tramways is 500-V DC tramways are fed from single overhead conductor acts as positive polarity that is fed at suitable points from either power station or substations and the track rail acts as return conductor.

The equipment used in tramways is similar to that used in railways but with small output not more than 40–50 kW. Usually, the tramways are provided with two driving axels to control the speed of the vehicles from either ends. The main drawback of tramways is they have to run along the guided routes only. Rehostatic and mechanical brakings can be applied to tramways. Mechanical brakes can be applied at low speeds for providing better saturation where electric braking is ineffective, during the normal service. The erection and maintenance costs of tramways are high since the cost of overhead distribution structure is costlier and sometimes, it may cause a source of danger to other road users.

Trolley buses: The main drawback of tramways is, running along the track is avoided in case of trolley buses. These are electrically operated vehicles, and are fed usually 600-V DC from two overhead conductors, by means of two collectors. Even though overhead distribution structure is costlier, the trolley buses are advantageous because, they eliminate the necessity of track in the roadways.

In case of trolley buses, rheostatic braking is employed, due to high adhesion between roads and rubber types. A DC compound motor is employed in trolley buses.

SYSTEM OF TRACK ELECTRIFICATION

Nowaday, based on the available supply, the track electrification system are categorized into.

1. DC system.
2. Single-phase AC system.
3. Three-phase AC system.
4. Composite system.

1 DC system

In this system of traction, the electric motors employed for getting necessary propelling torque should be selected in such a way that they should be able to operate on DC supply. Examples for such vehicles operating based on DC system are tramways and trolley buses. Usually, DC series motors are preferred for tramways and trolley buses even though DC compound motors are available where regenerative braking is desired. The operating voltages of vehicles for DC track electrification system are 600, 750, 1,500, and 3,000 V. Direct current at 600–750 V is universally employed for tramways in the urban areas and for many suburban and main line railways, 1,500–3,000 V is used. In some cases, DC supply for traction motor can be obtained from substations equipped with rotary converters to convert AC power to DC. These substations receive AC power from 3- ϕ high-voltage line or single-phase overhead distribution network. The operating voltage for traction purpose can be justified by the spacing between stations and the type of traction motors available. These substations are usually automatic and remote controlled and they are so costlier since they involve rotary converting equipment. The DC system is preferred for suburban services and road transport where stops are frequent and distance between the stops is small.

2 Single-phase AC system

In this system of track electrification, usually AC series motors are used for getting the necessary propelling power. The distribution network employed for such traction systems is normally 15–25 kV at reduced frequency of $1\frac{2}{3}$ Hz or 25 Hz. The main reason of operating at reduced frequencies is AC series motors that are more efficient and show better performance at low frequency. These high voltages are stepped down to suitable low voltage of 300–400 V by means of step-down transformer. Low frequency can be obtained from normal supply frequency with the help of frequency converter. Low-frequency operation of overhead transmission line reduces the line reactance and hence the voltage drops directly and single-phase AC system is mainly preferred for main line services where the cost of overhead structure is not much importance moreover rapid acceleration and retardation is not required for suburban services.

3 Three-phase AC system

In this system of track electrification, 3- ϕ induction motors are employed for getting the necessary propelling power. The operating voltage of induction motors is normally 3,000–3,600-V AC at either normal supply frequency or $1\frac{2}{3}$ -Hz frequency.

Usually 3- ϕ induction motors are preferable because they have simple and robust construction, high operating efficiency, provision of regenerative braking without placing any additional equipment, and better performance at both normal and seduced frequencies. In addition to the above advantages, the induction motors suffer from some drawbacks; they are low-starting torque, high-starting current, and the absence of speed control. The main disadvantage of such track electrification system is high cost of overhead distribution structure. This distribution system consists of two overhead wires and track rail for the third phase and receives power either directly from the generating station or through transformer substation.

Three-phase AC system is mainly adopted for the services where the output power required is high and regeneration of electrical energy is possible.

4 Composite system

As the above track electrification system have their own merits and demerits, 1- ϕ AC system is preferable in the view of distribution cost and distribution voltage

can be stepped up to high voltage with the use of transformers, which reduces the transmission losses. Whereas in DC system, DC series motors have most desirable features and for 3- ϕ system, 3- ϕ induction motor has the advantage of automatic regenerative braking. So, it is necessary to combine the advantages of the DC/AC and 3- ϕ /1- ϕ systems. The above cause leads to the evolution of composite system.

Composite systems are of two types.

1. Single-phase to DC system.
2. Single-phase to three-phase system or kando system.

Single-phase to DC system

In this system, the advantages of both 1- ϕ and DC systems are combined to get high voltage for distribution in order to reduce the losses that can be achieved with 1- ϕ distribution networks, and DC series motor is employed for producing the necessary propelling torque. Finally, 1- ϕ AC distribution network results minimum cost with high transmission efficiency and DC series motor is ideally suited for traction purpose. Normal operating voltage employed of distribution is 25 kV at normal frequency of 50 Hz. This track electrification is employed in India.

Single-phase to 3- ϕ system or kando system

In this system, 1- ϕ AC system is preferred for distribution network. Since single-phase overhead distribution system is cheap and 3- ϕ induction motors are employed as traction motor because of their simple, robust construction, and the provision of automatic regenerative braking.

The voltage used for the distribution network is about 15–25 kV at 50 Hz. This 1- ϕ supply is converted to 3- ϕ supply through the help of the phase converters and high voltage is stepped down transformers to feed the 3- ϕ induction motors. Frequency converters are also employed to get high-starting torque and to achieve better speed control with the variable supply frequency.

SPECIAL FEATURES OF TRACTION MOTORS

The general features of the electric motors used for traction purpose are:

1. Mechanical features.
2. Electrical features.

Mechanical features

1. A traction motor must be mechanically strong and robust and it should be capable of withstanding severe mechanical vibrations.
2. The traction motor should be completely enclosed type when placed beneath the locomotive to protect against dirt, dust, mud, etc.
3. In overall dimensions, the traction motor must have small diameter, to arrange easily beneath the motor coach.
4. A traction motor must have minimum weight so the weight of locomotive will decrease. Hence, the load carrying capability of the motor will increase.

Electrical features

High-starting torque

A traction motor must have high-starting torque, which is required to start the motor on load during the starting conditions in urban and suburban services.

Speed control

The speed control of the traction motor must be simple and easy. This is necessary for the frequent starting and stopping of the motor in traction purpose.

Dynamic and regenerative braking

Traction motors should be able to provide easy simple rheostatic and regenerative braking subjected to higher voltages so that system must have the capability of withstanding voltage fluctuations.

Temperature

The traction motor should have the capability of withstanding high temperatures during transient conditions.

Overload capacity

The traction motor should have the capability of handling excessive overloads.

Parallel running

In traction work, more number of motors need to run in parallel to carry more load. Therefore, the traction motor should have such speed–torque and current–torque characteristics and those motors may share the total load almost equally.

Commutation

Traction motor should have the feature of better commutation, to avoid the sparking at the brushes and commutator segments.

TRACTION MOTORS

No single motor can have all the electrical operating features required for traction.

In earlier days, DC motor is suited for traction because of the high-starting torque and having the capability of handling overloads. In addition to the above characteristics, the speed control of the DC motor is very complicated through semiconductor switches. So that, the motor must be designed for high base speed initially by reducing the number of turns in the field winding. But this will decrease the torque developed per ampere at the time of starting. And regenerative braking is also complicated in DC series motor; so that, the separately excited motors can be preferred over the series motor because their speed control is possible through semi-controlled converters. And also dynamic and regenerative braking in separately excited DC motor is simple and efficient.

DC compound motors are also preferred for traction applications since it is having advantageous features than series and separately excited motors.

But nowadays squirrel cage induction and synchronous motors are widely used for traction because of the availability of reliable variable frequency semiconductor inverters.

The squirrel cage induction motor has several advantages over the DC motors. They are:

1. Robust construction.
2. Highly reliable.
3. Low maintenance and low cost.
4. High efficiency.

Synchronous motor features lie in between the squirrel cage induction motor and the DC motor. The main advantages of the synchronous motor over the squirrel cage induction motor are:

1. The synchronous motors can be operated at leading power by varying the field excitation.
2. Load commutated thyristor inverter is used in synchronous motors as compared to forced commutation thyristor inverter in squirrel cage induction motors.

Even though such forced commutation reduces the weight and volume of induction motor, the synchronous motor is less expensive.

1. DC series motor

From the construction and operating characteristics of the DC series motor, it is widely suitable for traction purpose. Following features of series motor make it suitable for traction.

1. DC series motor is having high-starting torque and having the capability of handling overloads that is essential for traction drives.
2. These motors are having simple and robust construction.
3. The speed control of the series motor is easy by series parallel control.
4. Sparkless commutation is possible, because the increase in armature current increases the load torque and decreases the speed so that the emf induced in the coils undergoing commutation.
5. Series motor flux is proportional to armature current and torque. But armature current is independent of voltage fluctuations. Hence, the motor is unaffected by the variations in supply voltage.
6. We know that:

$$N \propto \frac{1}{\phi} \propto \frac{1}{I_a} \quad \text{and} \quad T \propto \phi I_a.$$

But for series motor $\phi \propto I_a$

$$\therefore T \propto I_a^2$$

$$\therefore N \propto \frac{1}{I_a} \propto \frac{1}{\sqrt{T}}.$$

But the power output of the motor is proportional to the product of torque and speed.

$$\therefore \text{Motor output} \propto T N \propto \sqrt{T}.$$

That is motor input drawn from the source is proportional to the square root of the torque. Hence, the series motor is having self-retaining property.

7. If more than one motor are to be run in parallel, their speed–torque and current–torque characteristics must not have wide variation, which may result in the unequal wear of driving wheels.

2 DC shunt motor

From the characteristics of DC shunt motor, it is not suitable for traction purpose, due to the following reasons:

1. DC shunt motor is a constant speed motor but for traction purpose, the speed of the motor should vary with service conditions.
2. In case of DC shunt motor, the power output is independent of speed and is proportional to torque. In case of DC series motor, the power output is proportional to \sqrt{T} . So that, for a given load torque, the shunt motor has to draw more power from the supply than series motor.
3. For shunt motor, the torque developed is proportional to armature current ($T \propto I_a$). So for a given load torque motor has to draw more current from the supply.
4. The flux developed by shunt motor is proportional to shunt field current and hence supply voltage. $\left[\because \phi_{sh} \propto I_{sh} \propto \frac{V}{R_{sh}} \right]$. But the torque developed is proportional to ϕ_{sh} and I_a . Hence, the torque developed by the shunt motor is affected by small variations in supply voltage.
5. If two shunt motors are running in parallel, their speed–torque and speed–current characteristics must be flat and same. Otherwise, the currents drawn by the motor from the supply mains will be different and cause to unequal sharing of load.

Example 9.1: A DC series motor drives a load. The motor takes a current of 13 A and the speed is 620 rpm. The torque of the motor varies as the square of speed. The field winding is shunted by a diverter of the same resistance as that of the field winding, then determine the motor speed and current. Neglect all motor losses and assume that the magnetic circuit is unsaturated.

Solution:

Before connecting field diverter:

Speed, $N_1 = 620$ rpm.

Series field current, $I_{se1} = 13 \text{ A}$.

The same current flows through the armature; so that,

$$I_1 = I_{se1} = I_{a1} = 13 \text{ A}.$$

After connecting field diverter, the field winding is shunted by the diverter of the same resistance; so that:

$$\text{Series field current} = I_{se2} = \frac{1}{2} I_2.$$

Since torque developed:

$$\begin{aligned} T &\propto \phi I_a \\ &\propto \phi I_1 \\ \frac{T_2}{T_1} &= \frac{T_2 I_2}{\phi_1 I_1} = \frac{1/2 I_2^2}{2 I_1^2} \quad \text{(i) } (\phi \propto I_{se} \text{ magnetic circuit is unsaturated}). \end{aligned}$$

According to given data, the torque varies as the square of the speed.

$$\frac{T_2}{T_1} = \frac{N_2^2}{N_1^2} \quad \text{(ii)}$$

From Equations (i) and (ii):

$$\frac{I_2^2}{2 I_1^2} = \frac{N_2^2}{N_1^2}$$

$$\frac{N_2}{N_1} = \frac{I_2}{\sqrt{2}I_1} \quad (\text{iii})$$

All the losses are neglected, and assume that the supply voltage is constant.

$$N \propto \frac{1}{\phi}$$

$$\frac{N_2}{N_1} = \frac{\phi_1}{\phi_2}$$

$$= \frac{I_1}{\frac{1}{2}I_2} \quad (\text{iv})$$

From Equations (iii) and (iv):

$$\frac{I_2}{\sqrt{2}I_1} = \frac{2I_1}{I_2}$$

$$I_2^2 = 2\sqrt{2} I_1^2$$

$$= 2 \times \sqrt{2} \times (13)^2$$

$$= 478.004.$$

$$\therefore I_2 = 21.86 \text{ A.}$$

From Equation (iv):

$$\frac{N_2}{N_1} = \frac{2I_1}{I_2}$$

$$N_2 = \frac{2I_1}{I_2} \times N_1$$

$$= 2 \times \frac{13}{21.86} \times 620$$

$$= 737.42 \text{ rpm.}$$

Example: A series motor having a resistance of 0.8Ω between its terminal drives. The torque of a fan is proportional to the square of the speed. At 220 V, its speed is 350 rpm and takes 12 A. The speed of the fan is to be raised to 400 rpm by supply voltage control. Estimate the supply voltage required.

Solution:

$$R_a + R_{sc} = 0.8 \Omega, V_1 = 220 \text{ V}, N_1 = 350 \text{ rpm}, I_1 = I_{a1} = 12 \text{ A}$$

$$N_2 = 400 \text{ rpm.}$$

Use the torque equation, $T \propto \phi I_a \propto I_a^2$ as $\phi \propto I_a$:

$$\frac{T_1}{T_2} = \left(\frac{I_{a1}}{I_{a2}} \right)^2 \quad \text{(i)}$$

Also $T \propto N^2$ (given)

$$\frac{T_1}{T_2} = \left(\frac{N_1}{N_2} \right)^2 \quad \text{(ii)}$$

Equating Equations (i) & (ii):

$$\begin{aligned} \left(\frac{N_1}{N_2} \right)^2 &= \left(\frac{I_{a1}}{I_{a2}} \right)^2 \\ \left(\frac{350}{400} \right)^2 &= \left(\frac{12}{I_{a2}} \right)^2 \\ \therefore I_{a2} &= 13.7 \text{ A.} \end{aligned}$$

Use the speed equation $N \propto \frac{E_b}{\phi} \propto \frac{E_b}{I_a}$

$$\frac{N_1}{N_2} = \frac{E_{b1}}{E_{b2}} \times \frac{I_{a2}}{I_{a1}} \quad \text{(iii)}$$

$$\begin{aligned} \text{Now, } E_{b1} &= V_1 - I_{a1}(R_a + R_{se}) \\ &= 220 - 12(0.8) = 210.4 \text{ V.} \end{aligned}$$

In second case, the voltage is to be changed from V_1 to V_2 .

$$\begin{aligned} \therefore E_{b2} &= V_2 - I_{a2}(R_a + R_{se}) \\ &= V_2 - 13.7(0.8) = V_2 - 10.96. \end{aligned}$$

E_{b1} and E_{b2} are substituted in Eq (iii):

$$\begin{aligned} \frac{350}{400} &= \frac{210.4}{V_2 - 10.96} \times \frac{13.7}{12} \\ V_2 - 10.96 &= 274.52 \\ V_2 &= 284.52 \text{ V.} \end{aligned}$$

\therefore This is the new supply voltage required to raise the speed from 350 rpm to 400 rpm.

Example: A 230-V DC shunt motor takes a current of 20 A on a certain load. The armature resistance is 0.8Ω and the field circuit resistance is 250Ω . Find the resistance to be inserted in series with the armature to have the speed is half if the load torque is constant.

Solution:

$$I_{L1} = 20 \text{ A.}$$

$$I_{sh} = \frac{V}{R_{sh}} = \frac{230}{250} = 0.92 \text{ A.}$$

$$I_{a1} = I_{L1} - I_{sh} = 20 - 0.92 = 19.08.$$

$$E_{b1} = V - I_{a1}R_a = 230 - 19.08(0.08) = 214.736 \text{ V.}$$

$$T \propto \phi I_a \propto I_a \quad (\because \phi \text{ is constant}).$$

$$\frac{T_1}{T_2} = \frac{I_{a1}}{I_{a2}} = 1 \quad \text{as torque is constant}$$

$$\therefore I_{a1} = I_{a2} = 19.08 \text{ A.}$$

R_x = external resistance in armature

$$E_{b2} = V - I_{a2}(R_a + R_x) = 230 - (19.08)(0.8 + R_x).$$

$$\text{Now, } N \propto \frac{E_b}{\phi} \propto E_b \quad (\because \phi \text{ is constant})$$

$$\therefore \frac{N_1}{N_2} = \frac{E_{b1}}{E_{b2}}$$

$$\frac{1}{0.5} = \frac{214.736}{230 - 19.08(0.8 + R_x)}$$

$$230 - 19.08(0.8 + R_x) = 214.736 \times 0.5 = 107.368$$

$$19.08(0.8 + R_x) = -107.368 + 230$$

$$= 122.632$$

$$0.8 + R_x = 6.43$$

$$R_x = 6.43 - 0.8$$

$$R_x = 5.62 \Omega.$$

AC series motor

Practically, AC series motor is best suited for the traction purpose due to high-starting torque (Fig. 9.1). When DC series motor is fed from AC supply, it works but not satisfactorily due to some of the following reasons:

1. If DC series motor is fed from AC supply, both the field and the armature currents reverse for every half cycle. Hence, unidirectional torque is developed at double frequency.

2. Alternating flux developed by the field winding causes excessive eddy current loss, which will cause the heating of the motor. Hence, the operating efficiency of the motor will decrease.
3. Field winding inductance will result abnormal voltage drop and low power factor that leads to the poor performance of the motor.
4. Induced emf and currents flowing through the armature coils undergoing commutation will cause sparking at the brushes and commutator segments.

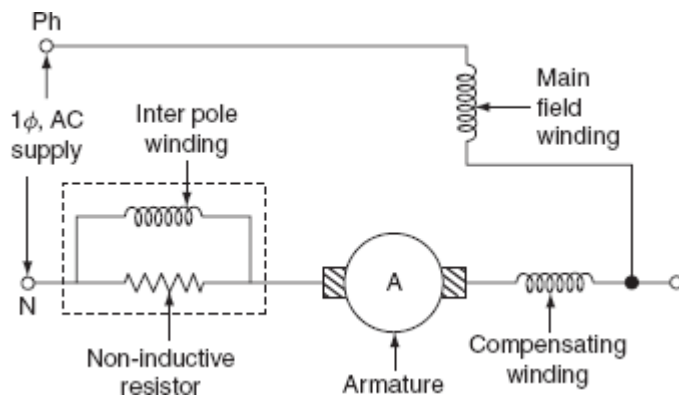

Fig. AC series motor

Hence, some modifications are necessary for the satisfactory operation of the DC series motor on the AC supply and they are as follows:

1. In order to reduce the inductive reactance of the series field, the field winding of AC series motor must be designed for few turns.
2. The decrease in the number of turns of the field winding reduces the load torque, i.e., if field turns decrease, its mmf decrease and then flux, which will increase the speed, and hence the torque will decrease. But in order to maintain constant load torque, it is necessary to increase the armature turns proportionately.
3. If the armature turns increase, the inductive reactance of the armature would increase, which can be neutralized by providing the compensating winding.
4. Magnetic circuit of an AC series motor should be laminated to reduce eddy current losses.
5. Series motor should be operating at low voltage because high voltage low current supply would require large number of turns to produce given flux.

6. Motor should be operating at low frequency, because inductive reactance is proportional to the frequency. So, at low frequency, the inductive reactance of the field winding decreases.

The operating characteristics of the AC series motor are similar to the DC series motor. Weight of an AC series motor is one and a half to two times that of a DC series motor. And operating voltage is limited to 300 V. They can be built up to the size of several hundred kW for traction work.

At the time of starting operation, the power factor is low; so that, for a given current, the torque developed by the AC motor is less compared to the DC motor. Thus, the AC series motor is not suitable for suburban services with frequent stops and preferred for main line service where high acceleration is not required.

Three-phase induction motor

The three-phase induction motors are generally preferred for traction purpose due to the following advantages.

1. Simple and robust construction.
2. Trouble-free operation.
3. The absence of commutator.
4. Less maintenance.
5. Simple and automatic regeneration.
6. High efficiency.

Three-phase induction motor also suffer from the following drawbacks.

1. Low-starting torque.
2. High-starting current and complicated speed control system.
3. It is difficult to employ three-phase induction motor for a multiple-unit system used for propelling a heavy train.

Three-phase induction motor draws less current when the motor is started at low frequencies. When a three-phase induction motor is used, the cost of overhead distribution system increases and it consists of two overhead conductors and track rail for the third phase to feed power to locomotive, which is a complicated overhead structure and if any person comes in contact with the third rail, it may cause danger to him or her.

This drawback can be overcome by employing kando system. In this system, 1- ϕ supply from the overhead distribution structure is converted to 3- ϕ supply by using phase converters and is fed to 3- ϕ induction motor.

The speed controller of induction motor becomes smooth and easy with the use of thyristorized inverter circuits to get variable frequency supply that can be used to control the speed of three-phase induction motor.

Nowadays, by overcoming the drawbacks of three-phase induction motor, it can be used for traction purpose.

Linear induction motor

It is a special type of induction motor that gives linear motion instead of rotational motion, as in the case of a conventional motor.

In case of linear induction motor, both the movement of field and the movement of the conductors are linear.

A linear induction motor consists of 3- ϕ distributed field winding placed in slots, and secondary is nothing but a conducting plate made up of either copper or aluminum as shown in Fig. .

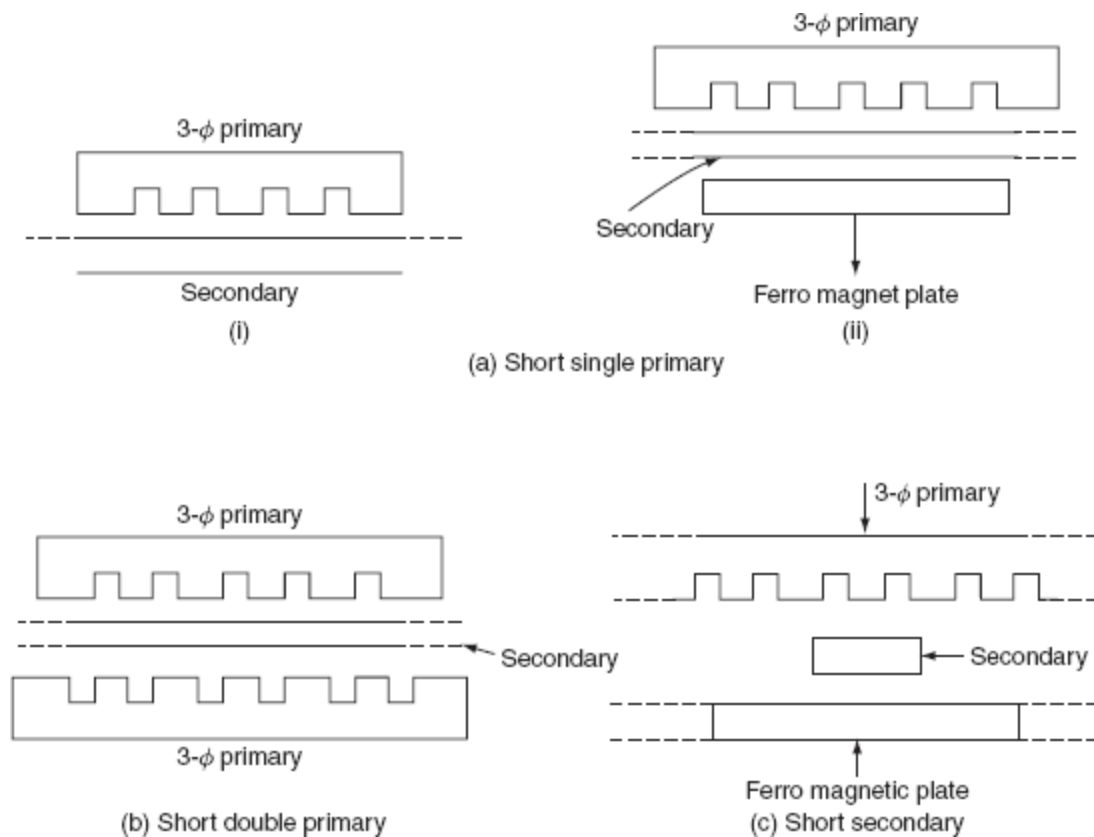

Fig Linear induction motor

The field system may be either single primary or double primary system. In single primary system, a ferro magnetic plate is placed on the other side of the copper plate; it is necessary to provide low reluctance path for the magnetic flux. When primary is excited by 3- ϕ AC supply, according to mutual induction, the induced currents are flowing through secondary and ferro magnetic plate. Now, the ferro magnetic plate energized and attracted toward the primary causes to unequal air gap between primary and secondary as shown in [Fig. 9.2\(a\)](#). This drawback can be overcome by double primary system as shown in [Fig. 9.2\(b\)](#). In this system, two primaries are placed on both the sides of secondary, which will be shorter in length compared to the other depending upon the use of the motor.

When the operating distance is large, the length of the primary is made shorter than the secondary because it is not economical to place very large 3- ϕ primary.

Generally, the short secondary form of system is preferred for limited operating distance, as shown in

When 3- ϕ primary winding is excited by giving 3- ϕ AC supply, magnetic field is developed rotating at linear synchronous speed, V_s .

The linear synchronous speed is given by:

$$V_s = 2\tau f \text{ m/s,}$$

where τ is the pole pitch in m and f is the supply frequency in hertz.

Note: here, the synchronous speed does not depend upon the number of poles but depends upon the pole pitch and the supply frequency.

1. Short single primary.
2. Short double primary.
3. Short secondary.

The flux developed by the field winding pulls the rotor same as to the direction of the magnetic field linearly, which will reduce relative speed between field and rotor plate. If the speed of the rotor plate is equal to the magnetic field, then the field would be stationary when viewed from the rotor plate. If rotor plate is rotating at a speed more than linear synchronous, the direction of a force would be reversed, which causes regenerative braking.

The slip of the linear induction motor is given by:

$$s = \frac{V_s - V}{V_s},$$

where 'V' is the actual speed of the rotor plate.

The speed–torque (tractive effort) characteristics is shown in Fig. 9.3.

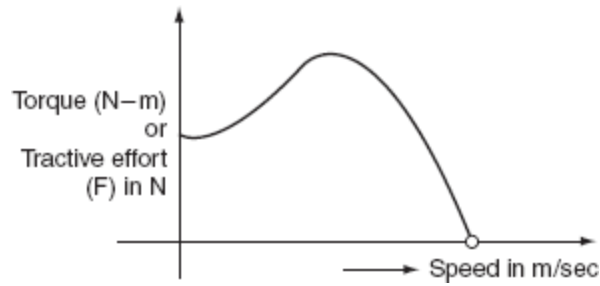

Fig. 9.3 Torque–speed characteristics

Therefore, force or tractive effort is given by:

$$F = \frac{P_2}{V_s},$$

where ‘ P_2 ’ is the actual power supply to the rotor.

Advantages

1. Simple in construction.
2. Low initial cost.
3. Maintenance cost is low.
4. Maximum speed is not limited due centrifugal forces.
5. Better power to weight ratio.

Disadvantages

1. High cost of providing collector system.
2. Poor efficiency and low power factor, due to high currents drawn by the motor because of large air gap.

Applications

Linear induction motor are generally used in:

- High-speed rail traction.
- Trolley cars and metallic belt conveyors.

- Electromagnetic pumps.

Synchronous motor

The synchronous motor is one type of AC motor working based upon the principle of magnetic locking. It is a constant speed motor running from no-load to full load. The construction of the synchronous motor is similar to the AC generator; armature winding is excited by giving three-phase AC supply and field winding is excited by giving DC supply. The synchronous motor can be operated at leading and lagging power factors by varying field excitation.

The synchronous motor can be widely used various applications because of constant speed from no-load to full load.

- High efficiency.
- Low-initial cost.
- Power factor improvement of three-phase AC industrial circuits.

BRAKING

If at any time, it is required to stop an electric motor, then the electric supply must be disconnected from its terminals to bring the motor to rest. In this method, even though supply is cut off, the motor continues to rotate for long time due to inertia. In some cases, there is delay in bringing the other equipment. So that, it is necessary to bring the motor to rest quickly. The process of bringing the motor to rest within the pre-determined time is known as braking.

A good braking system must have the following features:

- Braking should be fast and reliable.
- The equipment to stop the motor should be in such a way that the kinetic energy of the rotating parts of the motor should be dissipated as soon as the brakes are applied.

Braking applied to bring the motor to rest position is of two types and they are:

1. Electric braking.
2. Mechanical braking.

Electric braking

In this process of braking, the kinetic energy of the rotating parts of the motor is converted into electrical energy which in turn is dissipated as heat energy in a resistance or in sometimes, electrical energy is returned to the supply. Here, no energy is dissipated in brake shoes.

Mechanical braking

In this process of braking, the kinetic energy of the rotating parts is dissipated in the form of heat by the brake shoes of the brake lining that rubs on a wheel of vehicle or brake drum.

The advantages of the electric braking over the mechanical braking

- The electric braking is smooth, fast, and reliable.
- Higher speeds can be maintained; this is because the electric braking is quite fast. This leads to the higher capacity of the system.
- The electric braking is more economical; this is due to excessive wear on brake blocks or brake lining that results frequent and costly replacement in mechanical braking.
- Heat produced in the electric braking is less and not harmful but heat produced in the mechanical braking will cause the failure of brakes.
- In the electric braking, sometimes, it is possible to fed back electric energy during braking period to the supply system. This results in saving in the operating cost. This is not possible in case of mechanical braking.

Disadvantages

In addition to the above advantages, the electric braking suffers from the following disadvantages.

- During the braking period, the traction motor acts generator and electric brakes can almost stop the motor but it cannot hold stationary. Hence, it is necessary to employ mechanical braking in addition to electric braking.
- Traction motor has to work as a generator during braking period. So that, motor has to select in such a way that it should have suitable braking characteristics.
- The initial cost of the electric braking equipment is costlier.

TYPES OF ELECTRIC BRAKING

Electric braking can be applied to the traction vehicle, by any one of the following methods, namely:

1. Plugging.
2. Rheostatic braking.
3. Regenerative braking.

Plugging

In this method of braking, the electric motor is reconnected to the supply in such a way that it has to develop a torque in opposite direction to the movement of the rotor. Now, the motor will decelerates until zero speed is zero and then accelerates in opposite direction. Immediately, it is necessary to disconnect the motor from the supply as soon as system comes to rest.

The main disadvantage of this method is that the kinetic energy of the rotating parts of the motor is wasted and an additional amount of energy from the supply is required to develop the torque in reverse direction, i.e., in this method, the motor should be connected to the supply during braking. This method can be applied to both DC and AC motors.

Plugging applied to DC motors

Pulling is nothing but reverse current braking. This method of braking can be applied to both DC shunt and DC series motors by reversing either the current through armature or the field winding in order to produce the torque in apposite direction, but not both. The connection diagrams for both DC shunt and DC series motors during normal and braking periods are given as follows.

The connection diagram for normal running conditions of both DC shunt and DC series motors are shown in Figs. 9.4 (a) and 9.5 (a). The back emf developed by the motor is equal in magnitude and same as to the direction of terminal or supply voltage. During the braking, the armatures of both shunt and series motors are reversed as shown in Fig. 9.4 (b) and Fig. 9.5 (b). Now, the back emf developed by the motor direction of terminal voltage. A high resistance 'R' is connected in series with the armature to limit high-starting current during the braking period.

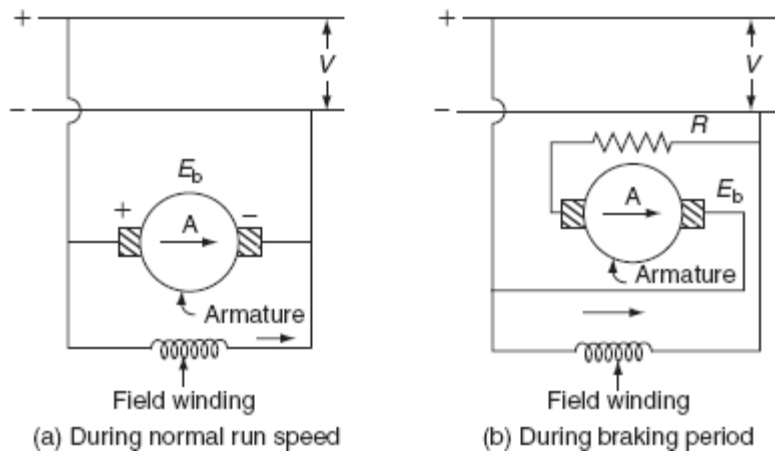

Fig. 9.4 Plugging of DC shunt motor

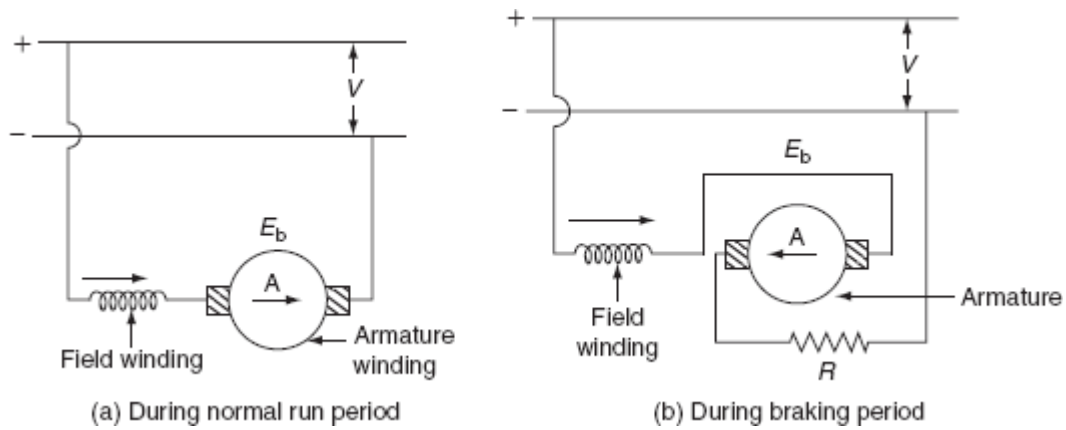

Fig. 9.5 Plugging of DC series motor

Current flowing through the armature during normal run condition:

$$I_1 = \frac{V - E_b}{R_a}, \quad (9.1)$$

where V is the supply voltage, E_b is the back emf, and R_a is the armature resistance.

Current flowing through the armature during braking period:

$$\begin{aligned} I_2 &= \frac{V - (-E_b)}{R_a + R} \\ &= \frac{V + E_b}{R_a + R} = \frac{V + E_b}{R'} \quad [\because R' = R_a + R]. \end{aligned}$$

\therefore Electric braking torque, $T_b \propto \phi I_2$.

$$\begin{aligned} T_B &= K_1 \phi I_2 \\ &= K_1 \phi \left(\frac{V + E_b}{R'} \right) \\ &= \frac{K_1 \phi V}{R'} + \frac{K_1 \phi E_b}{R'}. \end{aligned} \tag{9.2}$$

But we know that:

$$E_b \propto N\phi. \tag{9.3}$$

Substitute Equation (9.3) in Equation (9.2):

$$\begin{aligned}
\therefore T_B &= \frac{K_1 \phi V}{R'} + \frac{K_1 K_2 \phi^2 N}{R'} \\
&= \frac{K_1 \phi V}{R'} + \frac{K_3 \phi^2 N}{R'} && [\because K_3 = K_1 K_2] \\
&= K_4 \phi = K_5 \phi^2, && (9.4)
\end{aligned}$$

where $K_4 = \frac{K_1 V}{R'}$ and $K_5 = \frac{K_3 N}{R'}$.

We know that, in case of series motor flux (ϕ) developed by the winding is depending the current flowing through it.

$$\therefore T_B = K_6 I_a + K_7 I_a^2. \quad (9.5)$$

In case of shunt motor, the flux remains constant.

$$\therefore T_B = K_4 + K_5 N. \quad (9.6)$$

Plugging applied to induction motor

During the normal operating condition, the rotating magnetic field developed by the stator and the rotation of rotor are in the same direction. But during the braking period, plugging is applied to an induction motor by reversing any two phases of the three phases of stator winding in order to change the direction of the rotating magnetic field as shown in Fig. 9.6. So that, the rotating magnetic field and the rotor will be rotating in opposite direction. So that, the relative speed between emf and rotor is nearly twice the synchronous speed $N_s - (-N_s) = 2N_s$.

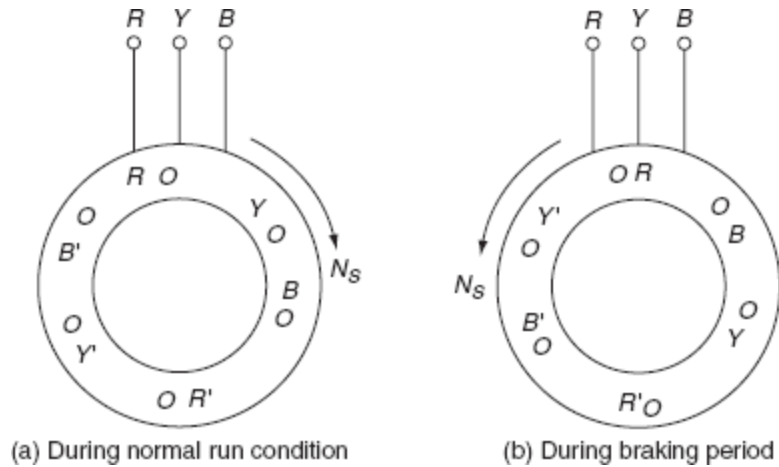

Fig. 9.6 Plugging applied to induction motor

∴ Slip during the braking period:

$$S = \frac{-N_s - N_s}{N_s} = \frac{-2N_s}{N_s} = -2.$$

But the voltage induced in the rotor (E_2) is proportional to the slip (S) \times stator voltage (V):

$$\therefore E_2 \propto SV.$$

So, the rotor voltage during the braking period is twice the normal voltage. To avoid the damage of the rotor winding, it should be provided with additional insulation, to withstand the high induced voltage.

The rotation of the magnetic field in the reverse direction produce torque in reverse direction; thereby applying the brakes to the motor. The braking of induction motor can be analyzed by the torque–slip characteristics shown in [Fig. 9.7](#).

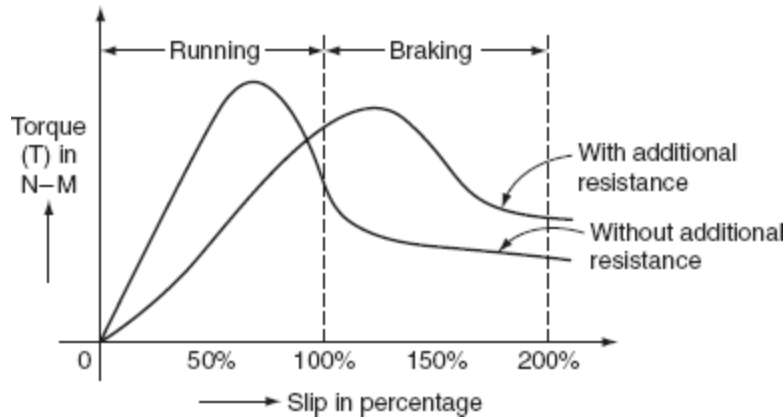

Fig. 9.7 Torque–slip characteristics

Rotor current during the braking period,
$$I_{2B} = \frac{SE_2}{\sqrt{R_2^2 + (SX^2)^2}}$$

The characteristic curve for the rotor current and the rotor voltage with the variation of the slip is shown in Fig. 9.8.

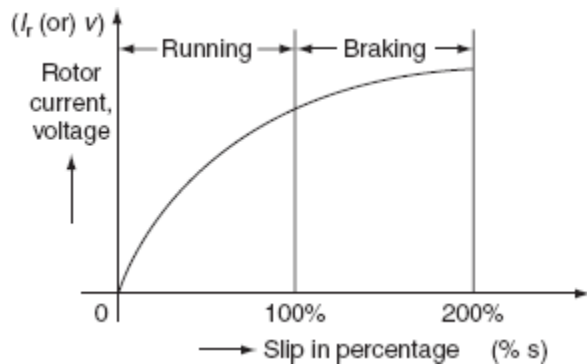

Fig. Rotor current–slip characteristics

Plugging applied to synchronous motor

Normally, the stator winding of the synchronous motor is fed with 3- ϕ AC supply to produce the rotating magnetic field that induces stator poles. And, the field winding is excited by giving the DC supply thereby inducing the rotor poles. At

any instant, the stator poles gets locked with the rotor poles and the synchronous motor rotating at the synchronous speed. In this method of plugging applied to synchronous motor, simply it is not possible to produce the counter torque during the braking period by interchanging any two of three phases. This is due to the magnetic locking of stator and rotor poles (Fig. 9.9).

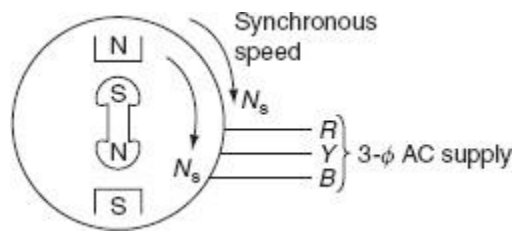

Fig. 9.9 Synchronous motor

In order to develop the counter torque, the rotor of synchronous motor should be provided with damper winding. The EMF induced in the damper winding whenever there is any change, i.e., the reversal of the direction of the stator field. Now, according to Lenz's law, the emf induced in the damper winding opposes the change which producing it. This emf induced in the damper winding produces the circulating current to produce the torque in the reverse direction. This torque is known as braking torque. This braking torque helps to bring the motor to rest.

Rheostatic or dynamic braking

In this method of braking, the electric motor is disconnected from the supply during the braking period and is reconnected across same electrical resistance. But field winding is continuously excited from the supply in the same direction. Thus, during the starts working as generator during the braking period and all the kinetic energy of the rotating parts is converted into electric energy and is dissipated across the external resistance.

One of the main advantages of the rehostatic braking is electrical energy is not drawn by the motor during braking period compared to plugging. The rehostatic braking can be applied to various DC and AC motors.

Rheostatic braking applied to DC motors

The rheostatic braking can be applied to both DC shunt and DC series motors, by disconnecting the armature from the supply and reconnecting it across an external resistance. This is required to dissipate the kinetic energy of all rotating parts thereby bringing the motor to rest.

DC shunt motor

Figure 9.10 shows the connection diagram of the DC shunt motor during both normal and braking conditions. In case of DC shunt motor, both armature and field windings are connected across the DC supply, as shown in Fig. 9.10 (a.)

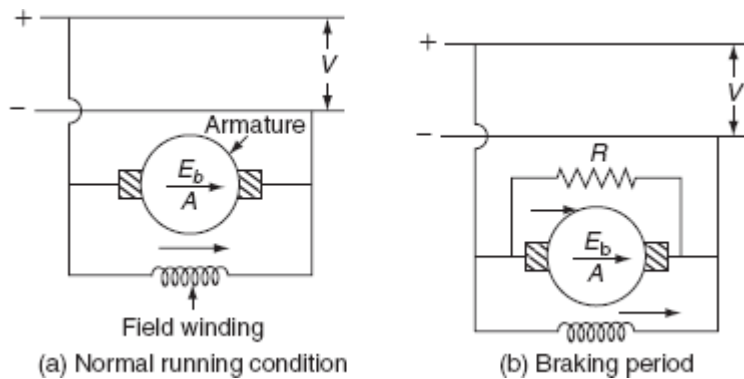

Fig. Rheostatic braking of DC shunt motor

During the braking period, the armature is disconnected from the supply and field winding is continuously excited by the supply in the same direction, as shown in Fig. 9.10 (b). The kinetic energy of all rotating parts is dissipated in the resistor ' R ' now the machine starts working as generator. Now, braking developed is proportional to the product of the field and the armature currents. But the shunt motor flux remains constant, so the braking torque is proportional to armature current at low-speeds braking torque is less and in order to maintain constant braking torque, the armature is gradually disconnected. Hence, the armature current remains same thereby maintaining the uniform braking torque.

DC series motor

In this braking, which is applied to DC series motor, the armature is disconnected from the supply and is reconnected across an external resistance ' R ' shown in Fig. 9.11 (a) and (b). But, simply, it is not possible to develop the retarding torque by the DC series motor after connecting armature across the resistance as DC shunt motor.

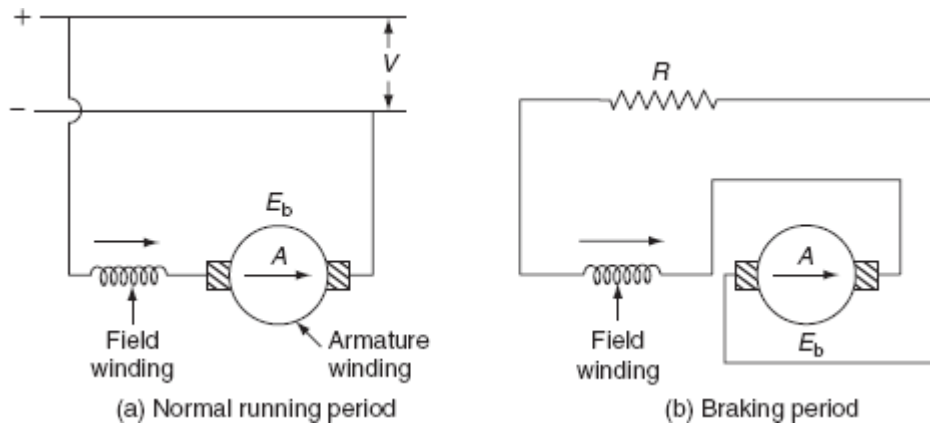

Fig. Rheostatic braking of DC series motor

In case of DC series motor, both the field and armature windings are connected across the resistance after disconnecting the same from the supply; current directions of both the field and armatures are reversed. This results in the production of torque in same direction as before. So, in order to produce the braking torque only the direction of current in the armature has to be reversed. The connection diagram of DC series is shown in Fig. 9.11.

If more than one motor has to be used as in electric traction. All motors can be connected in equalizer connection as shown in Fig. 9.12. In this connection, one machine is excited by the armature current of another machine.

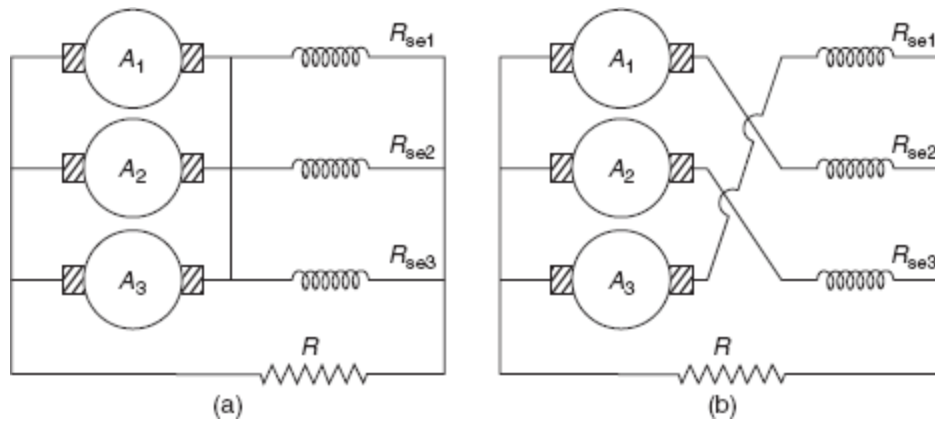

Fig. Equalizer connection

Braking torque

The current flowing through the armature during braking period:

$$I_a = \frac{E_b}{R + R_a}, \quad (9.7)$$

where E_b is the back emf developed, R is the external resistance, and R_a is the armature resistance.

And we know that, back emf $E_b \propto \phi N$
 $E_b = K_1 \phi N$.

$$\therefore \text{Braking current } I_a = \frac{K_1 \phi N}{R + R_a}. \quad (9.8)$$

Braking torque, $T_B \propto \phi I_a$.

$$\therefore T_B = K_2 \phi I_a. \quad (9.9)$$

Now, substitute Equation (9.8) in Equation (9.9):

$$\begin{aligned}\therefore T_B &= K_2 \phi \left[\frac{K_1 \phi N}{R + R_a} \right] \\ &= \frac{K_1 K_2 \phi^2 N}{R + R_a} = K_3 \phi^2 N \quad \left[\because K_3 = \frac{K_1 K_2}{R + R_a} \right].\end{aligned}$$

For shunt motor flux is practically constant:

$$\therefore T_B = K_5 I_a^2 N. \quad (9.10)$$

DC series motor

In case of DC series motor, it is not easy to apply regenerative braking as of DC shunt motor. The main reasons of the difficulty of applying regenerative braking to DC series motor are:

1. During the braking period, the motor acts as generator by reversing the direction of current flowing through the armature, but at the same time, the current flowing through the field winding is also reversed; hence, there is no retarding torque. And, a short-circuit condition will set up both back emf and supply voltage will be added together. So that, during the braking period, it is necessary to reverse the terminals of field winding.
2. Some sort of compensating equipment must be incorporated to take care of large change in supply voltage.

On doing some modifications during the braking period, the regenerative braking can be applied to DC series motor. Any one of the following methods is used.

Method-I (French method)

If one or more series motors are running in parallel, during the braking period, the field windings, of all series motors, are connected across the supply in series with

suitable resistance. Thereby converting all series machines in shunt machines as shown in Fig. 9.15.

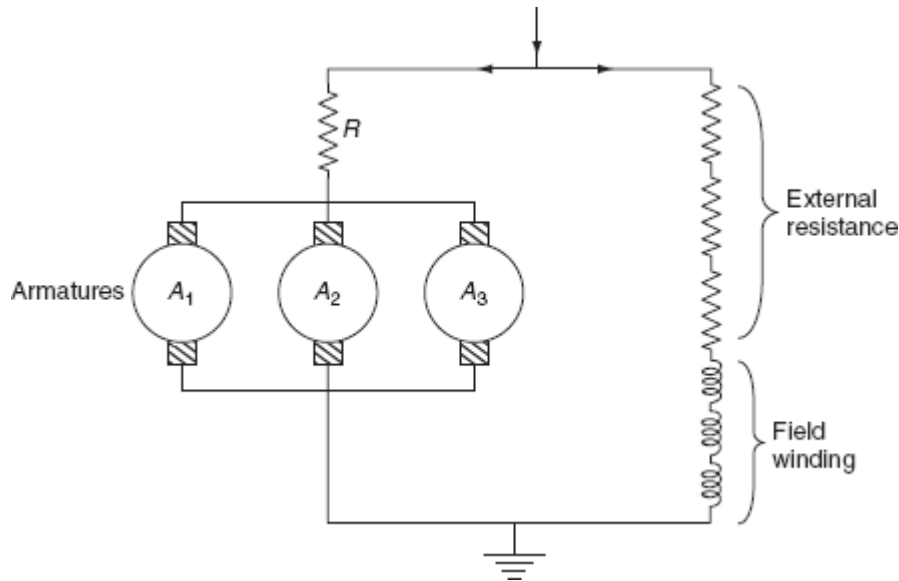

Fig. Regenerative braking of DC series motor

The main advantage of this method is, all armatures are connected in parallel and current supplied to one machine is sufficient to excite the field windings of all the machines, and the energy supplied by remaining all the machines is fed back to the supply system, during the braking period.

Method-II

In this method, the exciter is provided to excite the field windings of the series machine during the regenerative braking period. This is necessary to avoid the dissipation of energy or the loss of power in the external resistance.

Whenever the excitation of field winding is adjusted to increase the rotational emf more than the supply voltage, then the energy is supplied to the supply system. At that time, the field winding of the series machine is connected across an excited being driven by motor operated from an auxiliary supply. Now, during the braking period, the series machine acts as separately excited DC generator which supplies

energy to the main lines. A stabilizing resistance is used to control the braking torque (Figs. 9.16 and 9.17).

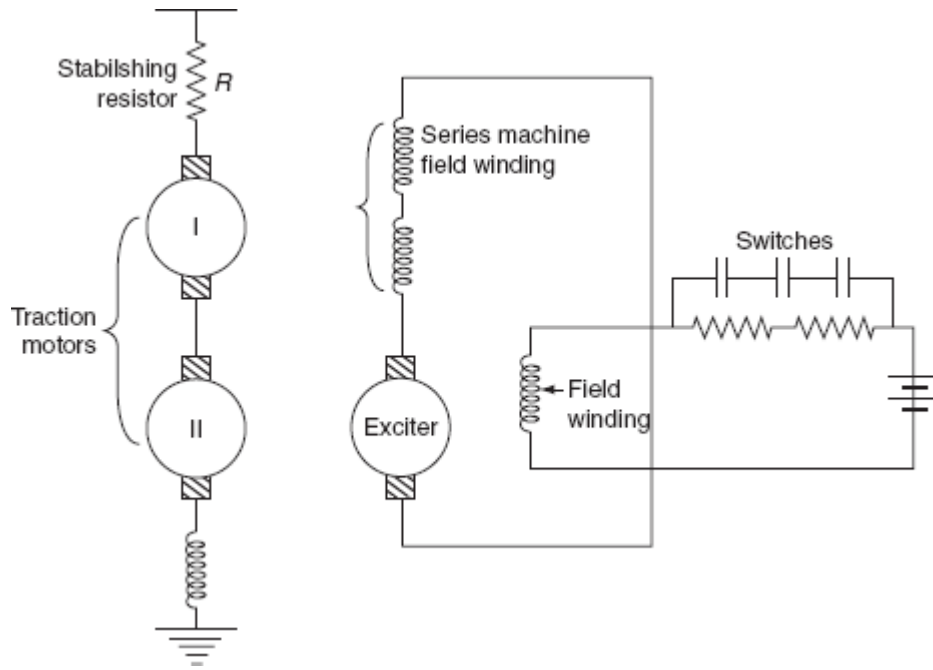

Fig. Regenerative braking

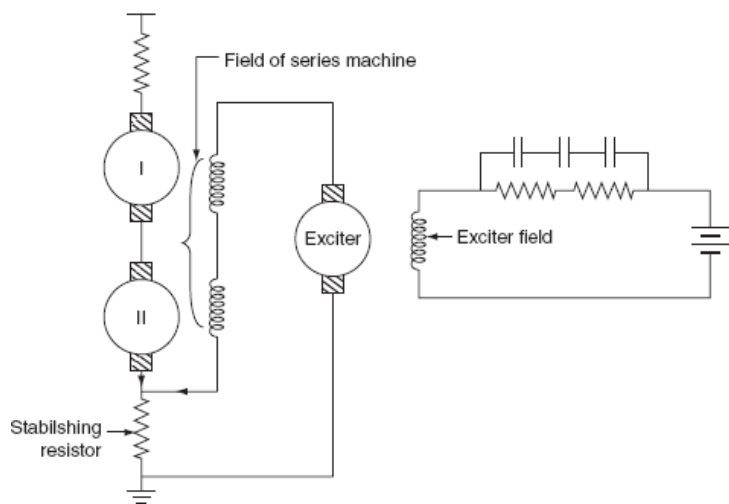

Fig. Regenerative braking

Method-III

In this method, the armature of exciter is connected in series. With the field winding of series machine, this combination is connected across the stabilizing resistance.

Here, the current flowing through stabilizing resistance is the sum of exciter current and regenerated current by the series machines.

During the braking period, the regenerated current increases the voltage drop across the stabilizing resistance, which will reduce the voltage across the armature circuit and cause the reduction of the exciter current of the series machine field winding. Hence, the traction motors operating as series generators.

Regenerative braking applied to 3- ϕ induction motor

Regenerative braking is applied to the induction motor by increasing its speed above the synchronous speed. Now, the induction motor acting as an induction generator that feeds power to the main line. The torque slip characteristics of the induction motors are shown in Fig. 9.18.

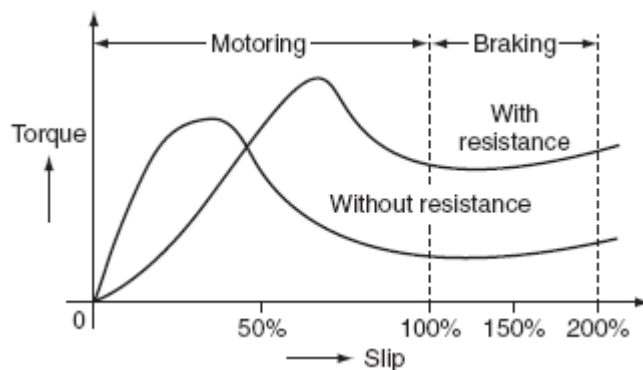

Fig. Torque vs slip characteristics

The main advantage of the induction motor is during the braking period; no need of placing external resistance in the rotor circuit. The speed during the braking remains almost constant and independent of the gradient and the weight of the train.

This regenerative braking applied to an induction motor can save 20% of the total energy leads the reduction of operating cost.

Regenerative braking applied to AC series motors

It is not simple way to apply regenerative braking to an AC series motor. In this method, the armature of traction motor is connected to the top changing transformer through iron cored reactors RE_1 and RE_2 and commutating pole winding 'C'.

An auxiliary transformer is provided to excite the field winding of the traction motor. Let us assume 'V' be the voltage of tap-changing transformer and I_f is the field current of traction motor. Due to the presence of reactor, I_f lags V by an angle 90° of traction motor is phase with exciting current as shown in Fig. 9.19.

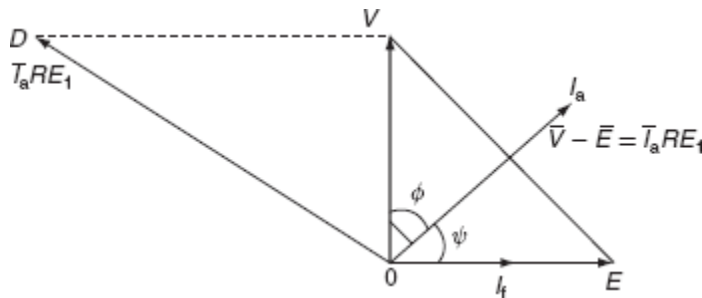

Fig. Phasor diagram

From the phasor diagram, the vector difference of \bar{V} and \bar{E} gives voltage across iron-cored reactor RE_1 . Now, the armature current I_a lags $\left(\bar{I}_a RE_1\right)$ by 90° . And, the braking torque developed the series machine will be proportional to $I_a \cos\phi$. And, the power returned to the supply is also proportional $I_a \cos\phi$. So that, proper phase angle must be obtained for efficient braking effect arise in the regenerative braking applied to an AC series motor are:

- During the regenerative braking, the braking torque is proportional to the operating power factor. In order to operate the series motor at high power factor field, winding must be excited separately from other auxiliary devices.
- Proper phase-shifting device must be incorporated to ensure correct phase angle.

To overcome the difficulty stated above, a special arrangement is adopted that is known as Behn Eschenburg method of regenerative braking.

The circuit diagram for applying regenerative braking to an AC series motor is shown in Fig. 9.20.

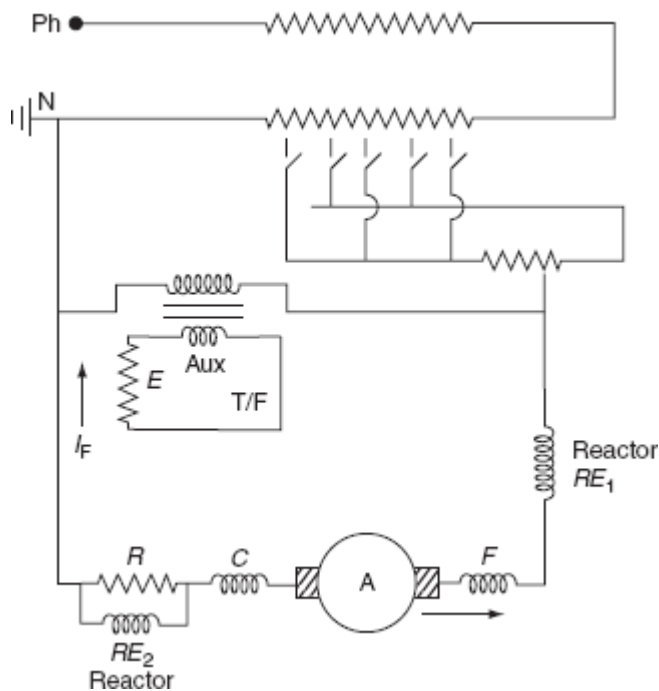

Fig. 9.20 Regenerative braking of AC series motor

TRACTION MOTOR CONTROL

Normally, at the time of starting, the excessive current drawn by the electric motor from the main supply causes to the effects. So that, it is necessary to reduce the current drawn by the traction motor for its smooth control such as:

1. To achieve smooth acceleration without any jerking and sudden shocks.

2. To prevent damage to coupling.
3. To achieve various speed depending upon the type of services.

Control of DC motors

At the time of starting, excessive current is drawn by the traction motor when rated voltage is applied across its terminals. During the starting period, the current drawn by the motor is limited to its rated current. This can be achieved by placing a resistance in series with the armature winding. This is known as starting resistance; it will be cut off during the normal running period thereby applying rated voltage across its armature terminals. By the resistance of starting resistor, there is considerable loss of energy takes place in it.

∴ At the time of switching on, the back emf developed by the motor $E_b = 0$.

$$\therefore \text{Supply voltage, } V = I_a R_a + V_s \quad (9.11)$$

where V_s is the voltage drop across starting resistance and $I_a R_a$ is the voltage drop in armature.

During the running condition:

$$V = I_a R_a + V_s + E_b \quad (9.12)$$

At the end of accelerating period, the total starting resistance will be cut off from the armature then:

$$V = I_a R_a + E_b \quad (9.13)$$

1. Various drops during starting and running with armature resistance.

2. Various drops during starting and running with negligible armature resistance.

When armature resistance is neglected $R_a = 0$ and 't' is the time in seconds for starting, then total energy supplied is, $V_a I_a t$ watts-sec and the energy wasted in the starting resistance at the time of starting can be calculated from Fig. 9.21(b) as:

$$\begin{aligned}
 &= \text{Area of } \Delta^{le}PQR \times I_a \\
 &= \frac{1}{2} t V I_a \\
 &= \frac{1}{2} V I_a t \text{ W-sec.}
 \end{aligned}
 \tag{9.14}$$

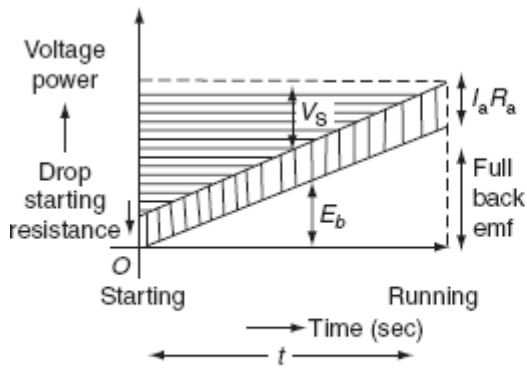

(a) Various drops during starting and running with armature resistance

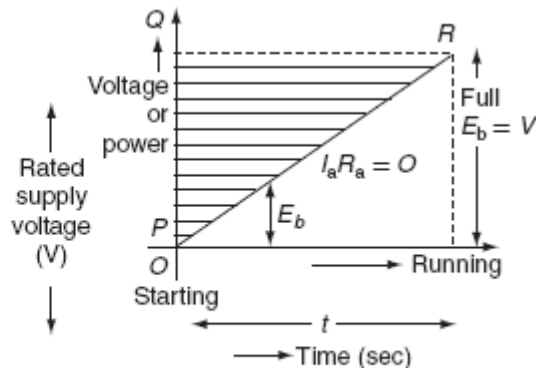

(b) Various drops during starting and running with negligible armature resistance

FigTraction control of DC motor

That is whatever the electrical energy supplied to the motor, half of the energy is wasted during the starting resistor.

∴ The efficiency of the traction motor at time of starting, $\eta_{start} = 50\%$.

AUXILIARY EQUIPMENT

A traction system comprises of the following auxiliary equipment in addition to the main traction motors required to be arranged in the locomotive are discussed below.

Motor–generator set

Motor–generator set consists of a series motor and shunt generator. It is mainly used for lighting, control system, and the other power circuits of low voltages in the range 10–100 V. The voltage of generator is effectively controlled by automatic voltage regulator.

Battery

It is very important to use the battery as a source of energy for pantograph, to run auxiliary compressor, to operate air blast circuit breaker, etc. The capacity of battery used in the locomotive is depending on the vehicle. Normally, the battery may be charged by a separate rectifier.

Rectifier unit

If the track electrification system is AC motors and available traction motors are DC motors, then rectifiers are to be equipped with the traction motors to convert AC supply to DC to feed the DC traction motors.

Transformer or autotransformer

Depending on the track electrification system employed, the locomotive should be equipped with tap-changing transformers to step-down high voltages from the distribution network to the feed low-voltage traction motors.

Driving axles and gear arrangements

All the driving motors are connected to the driving axle through a gear arrangement, with ratios of 4:1 or 6:1.

TRANSMISSION OF DRIVE

Drive is a system used to create the movement of electric train. The electric locomotives are specially designed to have springs between the driving axles and the main body. This arrangement of springs reduces the damage not only to the track wings but also to the hammer blows.

The power developed by the armature of the traction motors must be transferred to the driving axles through pinion and gear drive. There are several methods by which power developed by the armature can be transferred to the driving wheel.

Gearless drive

Gearless drives are of two types.

Direct drive

It is a simple drive. The armatures of the electric motors are mounted directly on the driving axle with the field attached to the frame of locomotive. In this system, the poles of electric motors should be flat so that the armature can be able to move freely without affecting of the operation. Here, the size of the armatures of the traction motor is limited by the diameter of the driving wheels. The arrangement of direct drive is shown in fig,

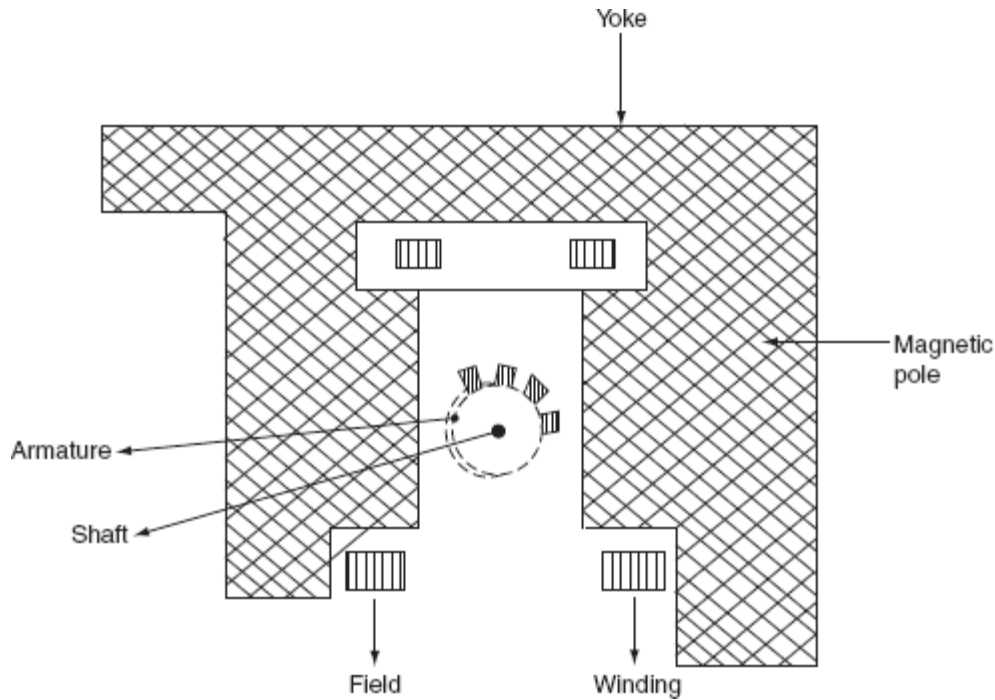

Fig. Direct drive

Direct quill drive

Quill is nothing but a hollow shaft. Driving axle is surrounded by the hollow shaft attached by springs. The armature of the motor is mounted on a quill. The speed and the size of the armature are limited by the diameter of the driving wheels.

Geared drive

In this drive, the armature of the traction motor is attached to the driving wheel through the gear wheel system. Now, the power developed by the armature is transferred to the driving wheel through the gear system. Here, gear drive is necessary to reduce the size of the motor for given output at high speeds (Fig. 9.33). The gear ratio of the system is usually 3–5:1.

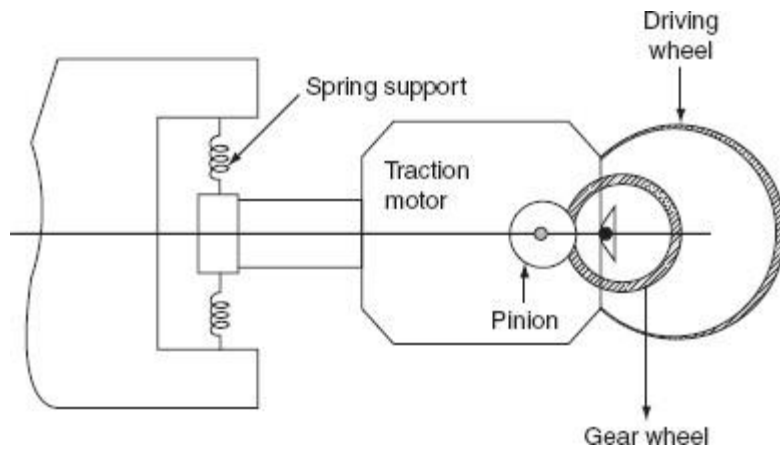

Fig. Geared drive

Brown-Boveri individual drive

In this drive, a special link is provided between the gear wheel and driving wheel, which provides more flexibility of the system.

UNIT 5

Electric Traction-II

INTRODUCTION

The movement of trains and their energy consumption can be most conveniently studied by means of the speed–distance and the speed–time curves. The motion of any vehicle may be at constant speed or it may consist of periodic acceleration and retardation. The speed–time curves have significant importance in traction. If the frictional resistance to the motion is known value, the energy required for motion of the vehicle can be determined from it. Moreover, this curve gives the speed at various time instants after the start of run directly.

TYPES OF SERVICES

There are mainly three types of passenger services, by which the type of traction system has to be selected, namely:

1. Main line service.
2. Urban or city service.
3. Suburban service.

Main line services

In the main line service, the distance between two stops is usually more than 10 km. High balancing speeds should be required. Acceleration and retardation are not so important.

Urban service

In the urban service, the distance between two stops is very less and it is less than 1 km. It requires high average speed for frequent starting and stopping.

Suburban service

In the suburban service, the distance between two stations is between 1 and 8 km. This service requires rapid acceleration and retardation as frequent starting and stopping is required.

SPEED–TIME AND SPEED–DISTANCE CURVES FOR DIFFERENT SERVICES

The curve that shows the instantaneous speed of train in kmph along the ordinate and time in seconds along the abscissa is known as '*speed–time*' curve.

The curve that shows the distance between two stations in km along the ordinate and time in seconds along the abscissa is known as '*speed–distance*' curve.

The area under the speed–time curve gives the distance travelled during, given time interval and slope at any point on the curve toward abscissa gives the acceleration and retardation at the instance, out of the two speed–time curve is more important.

Speed–time curve for main line service

Typical speed–time curve of a train running on main line service is shown in Fig. 10.1. It mainly consists of the following time periods:

1. Constant accelerating period.
2. Acceleration on speed curve.
3. Free-running period.
4. Coasting period.
5. Braking period.

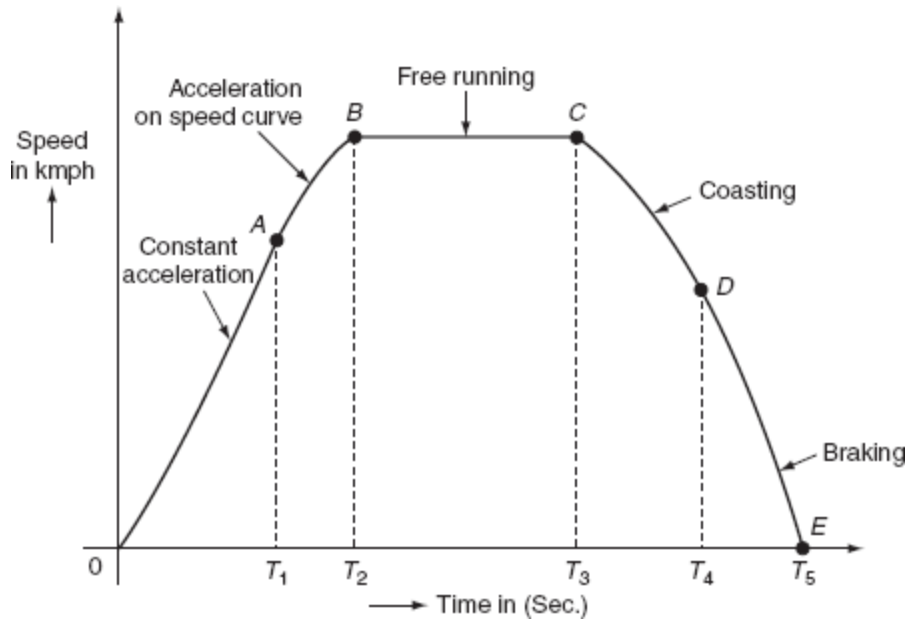

Fig. 10.1 Speed–time curve for mainline service

Constant acceleration

During this period, the traction motor accelerates from rest. The curve ‘OA’ represents the constant accelerating period. During the instant 0 to T_1 , the current is maintained approximately constant and the voltage across the motor is gradually increased by cutting out the starting resistance slowly moving from one notch to the other. Thus, current taken by the motor and the tractive efforts are practically constant and therefore acceleration remains constant during this period. Hence, this period is also called as notch up accelerating period or reostatic accelerating period. Typical value of acceleration lies between 0.5 and 1 kmph. Acceleration is denoted with the symbol ‘ α ’.

Acceleration on speed-curve

During the running period from T_1 to T_2 , the voltage across the motor remains constant and the current starts decreasing, this is because cut out at the instant ‘ T_1 ’.

According to the characteristics of motor, its speed increases with the decrease in the current and finally the current taken by the motor remains constant. But, at the same time, even though train accelerates, the acceleration decreases with the increase in speed. Finally, the acceleration reaches to zero for certain speed, at

which the tractive effort exerted by the motor is exactly equals to the train resistance. This is also known as decreasing accelerating period. This period is shown by the curve 'AB'.

Free-running or constant-speed period

The train runs freely during the period T_2 to T_3 at the speed attained by the train at the instant ' T_2 '. During this speed, the motor draws constant power from the supply lines. This period is shown by the curve BC.

Coasting period

This period is from T_3 to T_4 , i.e., from C to D. At the instant ' T_3 ' power supply to the traction, the motor will be cut off and the speed falls on account of friction, windage resistance, etc. During this period, the train runs due to the momentum attained at that particular instant. The rate of the decrease of the speed during coasting period is known as coasting retardation. Usually, it is denoted with the symbol ' β_c '.

Braking period

Braking period is from T_4 to T_5 , i.e., from D to E. At the end of the coasting period, i.e., at ' T_4 ' brakes are applied to bring the train to rest. During this period, the speed of the train decreases rapidly and finally reduces to zero.

In main line service, the free-running period will be more, the starting and braking periods are very negligible, since the distance between the stops for the main line service is more than 10 km.

Speed–time curve for suburban service

In suburban service, the distance between two adjacent stops for electric train is lying between 1 and 8 km. In this service, the distance between stops is more than the urban service and smaller than the main line service. The typical speed–time curve for suburban service is shown in Fig. 10.2.

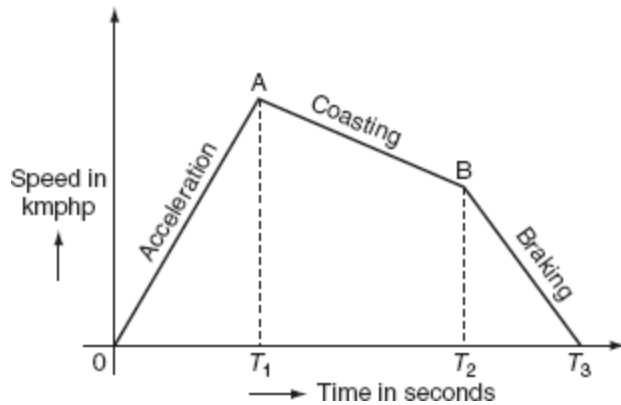

Fig. 10.2 Typical speed–time curve for suburban service

The speed–time curve for urban service consists of three distinct periods. They are:

1. Acceleration.
2. Coasting.
3. Retardation.

For this service, there is no free-running period. The coasting period is comparatively longer since the distance between two stops is more. Braking or retardation period is comparatively small. It requires relatively high values of acceleration and retardation. Typical acceleration and retardation values are lying between 1.5 and 4 kmph and 3 and 4 kmph, respectively.

Speed–time curve for urban or city service

The speed–time curve urban or city service is almost similar to suburban service and is shown in Fig. 10.3.

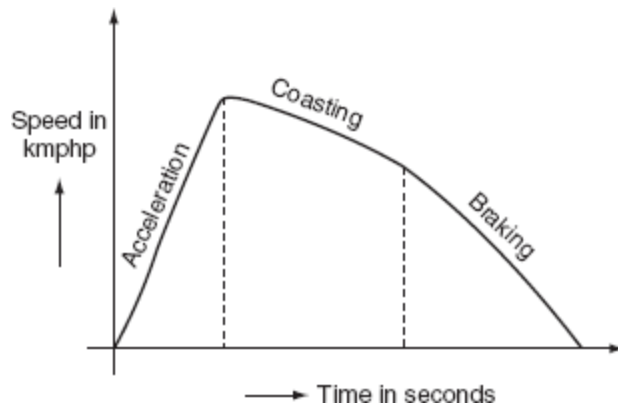

Fig. 10.3 Typical speed–time curve for urban service

In this service also, there is no free-running period. The distance between two stop is less about 1 km. Hence, relatively short coasting and longer braking period is required. The relative values of acceleration and retardation are high to achieve moderately high average between the stops. Here, the small coasting period is included to save the energy consumption. The acceleration for the urban service lies between 1.6 and 4 kmph. The coasting retardation is about 0.15 kmph and the braking retardation is lying between 3 and 5 kmph. Some typical values of various services are shown in Table. 10.1.

Table 10.1 Types of services

	<i>Mainline service</i>	<i>Suburban service</i>	<i>Urban service</i>
Distance between stops in km	More than 10	1–8	1
Maximum speed in kmph	160	120	120
Acceleration in kmph	0.5–0.9	1.5–4	1.5–4
Retardation in kmph	1.5	3–4	3–4
Features	Long free-run period, coasting and acceleration braking periods are small	No free-running period, coasting period is long	No free-running period, coasting period is small

SOME DEFINITIONS

Crest speed

The maximum speed attained by the train during run is known as crest speed. It is denoted with ' V_m '.

Average speed

It is the mean of the speeds attained by the train from start to stop, i.e., it is defined as the ratio of the distance covered by the train between two stops to the total time of run. It is denoted with ' V_a '.

$$\therefore \text{Average speed} = \frac{\text{distance between stops}}{\text{actual time of run}}$$

$$V_a = \frac{D}{T},$$

where V_a is the average speed of train in kmph, D is the distance between stops in km, and T is the actual time of run in hours.

Schedule speed

The ratio of the distance covered between two stops to the total time of the run including the time for stop is known as schedule speed. It is denoted with the symbol ' V_s '.

$$\therefore \text{Schedule speed} = \frac{\text{distance between stops}}{\text{total time of run} + \text{time for stop}}$$

$$= \frac{\text{distance between stops}}{\text{shedule time}}$$

$$V_s = \frac{D}{T_s},$$

where T_s is the schedule time in hours.

Schedule time

It is defined as the sum of time required for actual run and the time required for stop.

$$\therefore T_s = T_{\text{run}} + T_{\text{stop}}$$

FACTORS AFFECTING THE SCHEDULE SPEED OF A TRAIN

The factors that affect the schedule speed of a train are:

1. Crest speed.
2. The duration of stops.
3. The distance between the stops.
4. Acceleration.
5. Braking retardation.

Crest speed

It is the maximum speed of train, which affects the schedule speed as for fixed acceleration, retardation, and constant distance between the stops. If the crest speed increases, the actual running time of train decreases. For the low crest speed of train it running so, the high crest speed of train will increase its schedule speed.

Duration of stops

If the duration of stops is more, then the running time of train will be less; so that, this leads to the low schedule speed.

Thus, for high schedule speed, its duration of stops must be low.

Distance between the stops

If the distance between the stops is more, then the running time of the train is less; hence, the schedule speed of train will be more.

Acceleration

If the acceleration of train increases, then the running time of the train decreases provided the distance between stops and crest speed is maintained as constant. Thus, the increase in acceleration will increase the schedule speed.

Breaking retardation

High breaking retardation leads to the reduction of running time of train. These will cause high schedule speed provided the distance between the stops is small.

SIMPLIFIED TRAPEZOIDAL AND QUADRILATERAL SPEED TIME CURVES

Simplified speed–time curves gives the relationship between acceleration, retardation average speed, and the distance between the stop, which are needed to estimate the performance of a service at different schedule speeds. So that, the actual speed–time curves for the main line, urban, and suburban services are approximated to some from of the simplified curves. These curves may be of either trapezoidal or quadrilateral shape.

Analysis of trapezoidal speed–time curve

Trapezoidal speed–time curve can be approximated from the actual speed–time curves of different services by assuming that:

- The acceleration and retardation periods of the simplified curve is kept same as to that of the actual curve.
- The running and coasting periods of the actual speed–time curve are replaced by the constant periods.

This known as trapezoidal approximation, a simplified trapezoidal speed–time curve is shown in fig,

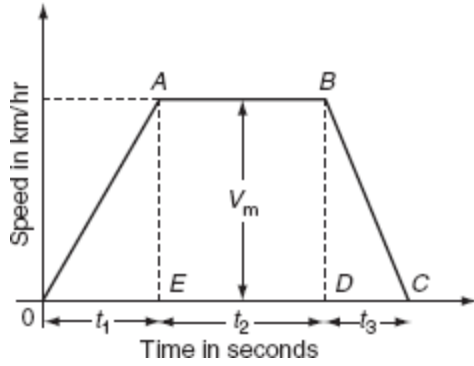

Fig. Trapezoidal speed–time curve

Calculations from the trapezoidal speed–time curve

Let D be the distance between the stops in km, T be the actual running time of train in second, α be the acceleration in km/h/sec, β be the retardation in km/h/sec, V_m be the maximum or the crest speed of train in km/h, and V_a be the average speed of train in km/h. From the Fig. 10.4:

$$\text{Actual running time of train, } T = t_1 + t_2 + t_3. \quad (10.1)$$

$$\text{Time for acceleration, } t_1 = \frac{V_m - 0}{\alpha} = \frac{V_m}{\alpha}. \quad (10.2)$$

$$\text{Time for retardation, } t_3 = \frac{V_m - 0}{\beta} = \frac{V_m}{\beta}. \quad (10.3)$$

$$= T - \left[\frac{V_m}{\alpha} + \frac{V_m}{\beta} \right]. \quad (10.4)$$

Area under the trapezoidal speed–time curve gives the total distance between the two stops (D).

\therefore The distance between the stops (D) = area under triangle OAE + area of rectangle $ABDE$ + area of triangle DBC

= The distance travelled during acceleration + distance travelled during free-running period + distance travelled during retardation.

Now:

The distance travelled during acceleration = average speed during accelerating period \times time for acceleration

$$\begin{aligned} &= \frac{0 + V_m}{2} \times t_1 \text{ km/h} \times \text{sec} \\ &= \frac{0 + V_m}{2} \times \frac{t_1}{3,600} \text{ km.} \end{aligned}$$

The distance travelled during free-running period = average speed \times time of free running

$$\begin{aligned} &= V_m \times t_2 \text{ km/h} \times \text{sec} \\ &= V_m \times \frac{t_2}{3,600} \text{ km.} \end{aligned}$$

The distance travelled during retardation period = average speed \times time for retardation

$$= \frac{V_m + 0}{2} \times t_3 \text{ km/h} \times \text{sec}$$

$$= \frac{0 + V_m}{2} \times \frac{t_3}{3,600} \text{ km.}$$

The distance between the two stops is:

$$D = \frac{V_m}{2} \times \frac{t_1}{3,600} + V_m \times \frac{t_2}{3,600} + \frac{V_m}{2} \times \frac{t_3}{3,600}$$

$$D = \frac{V_m t_1}{7,200} + \frac{V_m}{3,600} [T - V_m (t_1 + t_2)] + \frac{V_m t_3}{7,200}$$

$$D = \frac{V_m^2}{7,200\alpha} + \frac{V_m}{3,600} \left[T - V_m \left(\frac{1}{\alpha} + \frac{1}{\beta} \right) \right] + \frac{V_m^2}{7,200\beta}$$

$$3,600 \times D = \frac{V_m^2}{2\alpha} + \frac{V_m^2}{\beta} - V_m^2 \left(\frac{1}{\alpha} + \frac{1}{\beta} \right) + V_m T$$

$$3,600 D = V_m^2 \left(\frac{1}{2\alpha} - \frac{1}{\alpha} \right) + V_m^2 \left(\frac{1}{2\beta} - \frac{1}{\beta} \right) + V_m T$$

$$3,600 D = \frac{-V_m^2}{2\alpha} - \frac{V_m^2}{2\beta} + V_m T$$

$$\therefore V_m^2 \left[\frac{1}{2\alpha} + \frac{1}{2\beta} \right] - V_m T + 3,600 D = 0.$$

$$\text{Let } \frac{1}{2\alpha} + \frac{1}{2\beta} = X = \frac{\alpha + \beta}{2\alpha\beta}$$

$$\therefore V_m^2 X - V_m T + 3,600 D = 0. \quad (10.5)$$

Solving quadratic Equation (10.5), we get:

$$V_m = \frac{T + \sqrt{T^2 - 4 \times X \times 3,600D}}{2 \times X}$$

$$= \frac{T}{2X} \pm \sqrt{\frac{T^2}{4X^2} - \frac{3,600D}{X}}$$

By considering positive sign, we will get high values of crest speed, which is practically not possible, so negative sign should be considered:

$$V_m = \frac{T}{2X} - \sqrt{\frac{T^2}{4X^2} - \frac{3,600D}{X}} \quad (10.6)$$

$$\text{Or, } V_m = \frac{\alpha\beta}{\alpha+\beta} T - \sqrt{\left(\frac{\alpha\beta}{\alpha+\beta}\right)^2 T^2 - 7,200 \left(\frac{\alpha\beta}{\alpha+\beta}\right) D}$$

Analysis of quadrilateral speed–time curve

Quadrilateral speed–time curve for urban and suburban services for which the distance between two stops is less. The assumption for simplified quadrilateral speed–time curve is the initial acceleration and coasting retardation periods are extended, and there is no free-running period. Simplified quadrilateral speed–time curve is shown in Fig. 10.5.

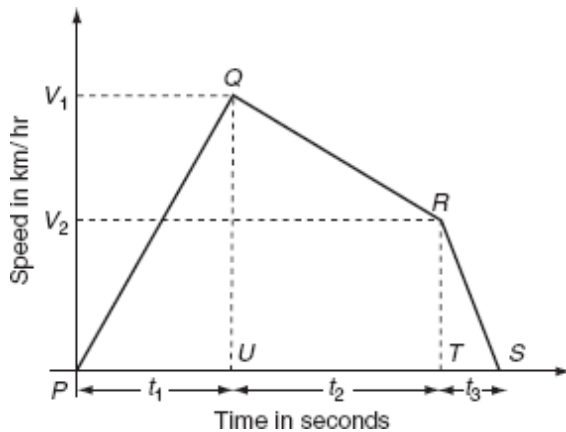

Fig. Quadrilateral speed–time curve

Let V_1 be the speed at the end of accelerating period in km/h, V_2 be the speed at the end of coasting retardation period in km/h, and β_c be the coasting retardation in km/h/sec.

$$\text{Time for acceleration, } t_1 = \frac{V_1 - 0}{\alpha} = \frac{V_1}{\alpha}.$$

$$\text{Time for coasting period, } t_2 = \frac{V_2 - V_1}{\beta}.$$

$$\text{Time period for braking retardation period, } t_3 = \frac{V_2 - 0}{\beta} = \frac{V_2}{\beta}.$$

Total distance travelled during the running period D :

= the area of triangle PQU + the area of rectangle $UQRS$ + the area of triangle TRS .

= the distance travelled during acceleration + the distance travelled during coasting retardation + the distance travelled during braking retardation.

But, the distance travelled during acceleration = average speed \times time for acceleration

$$\begin{aligned} &= \frac{0 + V_1}{2} \times t_1 \text{ km/h} \times \text{sec} \\ &= \frac{V_1}{2} \times \frac{t_1}{3,600} \text{ km.} \end{aligned}$$

$$\text{The distance travelled during coasting retardation} = \frac{V_2 + V_1}{2} \times t_2 \text{ km/h} \times \text{sec}$$

$$= \frac{V_2 + V_1}{2} \times \frac{t_2}{3,600} \text{ km.}$$

The distance travelled during breaking retardation = average speed \times time for breaking retardation

$$= \frac{0 + V_2}{2} \times t_3 \text{ km/h} \times \text{sec}$$

$$= \frac{V_2}{2} \times \frac{t_3}{3,600} \text{ km.}$$

\therefore Total distance travelled:

$$D = \frac{V_1}{2} \times \frac{t_1}{3,600} + \frac{(V_1 + V_2)}{2} \frac{(t_2)}{3,600} + \frac{V_2}{2} \times \frac{t_3}{3,600}$$

$$= \frac{V_1 t_1}{7,200} + \frac{(V_1 + V_2) t_2}{7,200} + \frac{V_2 t_3}{7,200}$$

$$= \frac{V_1}{7,200} (t_1 + t_2) + \frac{V_2}{7,200} (t_2 + t_3)$$

$$= \frac{V_1}{7,200} (T - t_3) + \frac{V_2}{7,200} (T - t_1)$$

$$= \frac{(V_1 + V_2) T}{7,200} - \frac{V_1 t_3}{7,200} - \frac{V_2 t_1}{7,200}$$

$$= \frac{(V_1 + V_2) T}{7,200} - \frac{V_1 V_2}{7,200 \beta} - \frac{V_1 V_2}{7,200 \alpha}$$

$$= \frac{T}{7,200} (V_1 + V_2) - \frac{V_1 V_2}{7,200} \left(\frac{1}{\alpha} + \frac{1}{\beta} \right)$$

$$7,200 D = (V_1 + V_2) T - V_1 V_2 \left(\frac{1}{\alpha} + \frac{1}{\beta} \right). \quad (10.7)$$

Example 10.1: The distance between two stops is 1.2 km. A schedule speed of 40 kmph is required to cover that distance. The stop is of 18-s duration. The values of the acceleration and retardation are 2 kmph and 3 kmph, respectively. Then, determine the maximum speed over the run. Assume a simplified trapezoidal speed–time curve.

Solution:

Acceleration $\alpha = 2.0$ kmph.

Retardation $\beta = 3$ kmph.

Schedule speed $V_s = 40$ kmph.

Distance of run, $D = 1.2$ km.

$$\begin{aligned}\text{Schedule time, } T_s &= \frac{D \times 3,600}{V_s} \\ &= \frac{1.2 \times 3,600}{40} \\ &= 108 \text{ s.}\end{aligned}$$

Actual run time, $T = T_s - \text{stop duration}$

$$= 108 - 18$$

$$= 90 \text{ s.}$$

$$\text{Maximum speed } V_m = \frac{T}{2X} - \sqrt{\frac{T^2}{4X^2} - \frac{3,600D}{X}},$$

where

$$\begin{aligned}
X &= \frac{1}{2\alpha} + \frac{1}{2\beta} \\
&= \frac{1}{2 \times 2} + \frac{1}{2 \times 3} \\
&= 0.416. \\
\therefore V_m &= \frac{90}{2 \times 0.416} - \sqrt{\frac{(90)^2}{4 \times (0.416)^2} - \frac{3,600 \times 1.2}{0.416}} \\
&= 108.173 - \sqrt{(1,1701.414) - (1,0384.61)} \\
&= 71.88 \text{ kmph.}
\end{aligned}$$

Example 10.2: The speed–time curve of train carries of the following parameters:

1. Free running for 12 min.
2. Uniform acceleration of 6.5 kmphp for 20 s.
3. Uniform deceleration of 6.5 kmphp to stop the train.
4. A stop of 7 min.

Then, determine the distance between two stations, the average, and the schedule speeds.

Solution:

Acceleration (α) = 6.5 kmphps.

Acceleration period $t_1 = 20$ s.

Maximum speed $V_m = \alpha t_1$

$$= 6.5 \times 20 = 130 \text{ kmph.}$$

Free-running time (t_2) = 12 × 60

$$= 720 \text{ s.}$$

$$\begin{aligned}
\text{Time for retardation, } (t_3) &= \frac{V_m}{\beta} \\
&= \frac{130}{6.5} = 20 \text{ s.}
\end{aligned}$$

The distance travelled during the acceleration period:

$$\begin{aligned} D_1 &= \frac{1}{2} \frac{V_m t_1}{3,600} \\ &= \frac{1}{2} \times \frac{130 \times 20}{3,600} \\ &= 0.36 \text{ km.} \end{aligned}$$

The distance travelled during the free-running period:

$$\begin{aligned} D_2 &= \frac{V_m t_2}{3,600} \\ &= \frac{130 \times 720}{3,600} \\ &= 26 \text{ km.} \end{aligned}$$

The distance travelled during the braking period $D_3 = \frac{V_m t_3}{7,200}$

$$\begin{aligned} &= \frac{130 \times 20}{7,200} \\ &= 0.362 \text{ km.} \end{aligned}$$

The distance between the two stations:

$$\begin{aligned} D &= D_1 + D_2 + D_3 \\ &= 0.36 + 26 + 0.362 \\ &= 26.724 \text{ km.} \end{aligned}$$

$$\begin{aligned} \text{Average distance } (V_{\text{avg}}) &= \frac{D \times 3600}{T} \\ &= \frac{26.724 \times 3600}{20 + 720 + 20} \\ &= 126.58 \text{ kmph.} \end{aligned}$$

$$\begin{aligned} \text{Schedule speed } (V_s) &= \frac{D \times 3600}{T + \text{stoptime}} \\ &= \frac{26.724 \times 3,600}{20 + 720 + 20 + 70 \times 60} \\ &= 81.53 \text{ kmph.} \end{aligned}$$

Example 10.3: An electric train is to have the acceleration and braking retardation of 0.6 km/hr/sec and 3 km/hr/sec, respectively. If the ratio of the maximum speed to the average speed is 1.3 and time for stop is 25 s. Then determine the schedule speed for a run of 1.6 km. Assume the simplified trapezoidal speed–time curve.

Solution:

Acceleration $\alpha = 0.6 \text{ km/hr/s}$.

Retardation $\beta = 3 \text{ km/hr/s}$.

Distance of run $D = 1.6 \text{ km}$.

Let the cultural time of run be ‘ T ’ s.

$$\begin{aligned} \text{Average speed } V_a &= \frac{3,600D}{T} \\ &= \frac{3,600 \times 1.6}{T} \\ &= \frac{5,760}{T} \text{ kmph.} \end{aligned}$$

$$\begin{aligned} \text{Maximum speed} &= 1.3V_a \\ &= 1.3 \times \frac{5,760}{T} \end{aligned}$$

$$= \frac{7,488}{T} \text{ km/hr}$$

$$V_m^2 \left[\frac{1}{2\alpha} + \frac{1}{2\beta} \right] - V_m T + 3,600 = D$$

$$V_m^2 = \frac{V_m T - 3,600 D}{\left(\frac{1}{2\alpha} + \frac{1}{2\beta} \right)}$$

$$= \frac{\frac{7,488}{T} \times T - 3,600 \times 1.6}{\left(\frac{1}{2 \times 0.6} + \frac{1}{2 \times 3} \right)}$$

$$= \frac{7,488 - 5,760}{0.833 + 0.166}$$

$$= 1,729.729$$

$$\therefore V_m = 41.59 \text{ km/hr.}$$

$$\text{Average speed, } (V_a) = \frac{V_m}{1.3} = \frac{41.59}{1.3}$$

$$(V_a) = 31.9923 \text{ kmph.}$$

$$\begin{aligned} \text{Actual time of run } T &= \frac{3,600 D}{V_a} \\ &= \frac{3,600 \times 1.6}{31.9923} \end{aligned}$$

$$T = 180.0433 \text{ s.}$$

$$\begin{aligned} \text{Schedule time } T_s &= \text{Actual time of run} + \text{time of stop} \\ &= 180.0433 + 25 \\ &= 205.0433 \text{ s.} \end{aligned}$$

$$\begin{aligned} \text{Schedule speed } V_s &= \frac{D \times 3,600}{T_s} \\ &= \frac{1.6 \times 3,600}{205.0433} \\ &= 28.0916 \text{ kmph.} \end{aligned}$$

Example 10.4: The distance between two stops is 5 km. A train has schedule speed of 50 kmph. The train accelerates at 2.5 kmph/s and retards 3.5 kmph/s and the duration of stop is 55 s. Determine the crest speed over the run assuming trapezoidal speed–time curve.

Solution:

Acceleration (α) = 2.5 kmphps.

Retardation (β) = 3.5 kmphps.

Distance of run (D) = 5 km.

Schedule speed (V_s) = 50 kmph.

$$\begin{aligned}\text{Schedule time, } T_s &= \frac{D}{V_s} \times 3,600 \\ &= \frac{5}{50} \times 3,600 \\ &= 360 \text{ s.}\end{aligned}$$

$$\begin{aligned}\text{Actual time of run } T &= T_s - \text{Time of stop} \\ &= 360 - 55 \\ &= 305 \text{ s.}\end{aligned}$$

By using the equation:

$$\begin{aligned}V_m &= \frac{T}{2X} - \sqrt{\frac{T^2}{4X^2} - \frac{3,600D}{X}} \\ X &= \frac{1}{2\alpha} + \frac{1}{2\beta} \\ &= \frac{1}{2 \times 2.5} + \frac{1}{2 \times 3.5} \\ &= 0.2 + 0.1428 \\ &= 0.3428. \\ \therefore V_m &= \frac{305}{2 \times 0.3428} - \sqrt{\frac{(305)^2}{4 \times (0.3428)^2} - \frac{3600 \times 5}{0.3428}} \\ &= 444.868 - \sqrt{197,905.5898 - 52,508.75146} \\ &= 63.556 \text{ kmph.}\end{aligned}$$

Example 10.5: A train is required to run between two stations 1.5 km apart at an average speed of 42 kmph. The run is to be made to a simplified quadrilateral speed–time curve. If the maximum speed is limited to 65 kmph, the acceleration to

, kmphs, and the coasting and braking retardation to 0.15 kmphs and 3 kmphs, respectively. Determine the duration of acceleration, coasting, and braking periods.

Solution:

Distance between two stations $D = 1.5$ km.

Average speed $V_a = 42$ kmph.

Maximum speed $V_m = 65$ kmph.

Acceleration (α) = 2.5 kmphs.

Coasting retardation $\beta_c = 0.15$ kmphs.

Braking retardation $\beta = 3$ kmphs.

$$\begin{aligned} \text{The duration of acceleration } t_1 &= \frac{V_m}{\alpha} \\ &= \frac{65}{2.5} \\ &= 26 \text{ s.} \end{aligned}$$

$$\text{The actual time of run, } T = \frac{3,600 \times D}{V_a} = \frac{3,600 \times 1.5}{42} = 128.57 \text{ s.}$$

Before applying brakes; let the speed be V_2 .

$$\begin{aligned} \text{The duration of coasting, } t_2 &= \frac{V_m - V_2}{\beta_c} \\ &= \frac{65 - V_2}{0.15} \text{ s.} \end{aligned}$$

$$\begin{aligned} \text{The duration of braking } t_3 &= \frac{V_2}{\beta} \\ &= \frac{V_2}{3} \text{ s.} \end{aligned}$$

The actual time of run, $T = t_1 + t_2 + t_3$

$$\begin{aligned}128.557 &= 26 + \frac{65 - V_2}{0.15} + \frac{V_2}{3} \\102.57 &= 433.33 - 6.66V_2 + 0.33V_2 \\330.76 &= 6.33V_2 \\V_2 &= 52.252 \text{ km/hr.}\end{aligned}$$

The duration of coasting, $t_2 = \frac{V_m - V_2}{\beta_c}$

$$\begin{aligned}&= \frac{65 - 52.252}{0.15} \\&= 84.98 \text{ s.}\end{aligned}$$

Duration of braking (t_3) = $\frac{V_2}{\beta}$

$$\begin{aligned}&= \frac{52.252}{3} \\&= 17.4173 \text{ s.}\end{aligned}$$

Example 10.6: A train has schedule speed of 32 kmph over a level track distance between two stations being 2 km. The duration of stop is 25 s. Assuming the braking retardation of 3.2 kmphs and the maximum speed is 20% greater than the average speed. Determine the acceleration required to run the service.

Solution:

Schedule speed $V_s = 32$ kmph.

Distance $D = 2$ km.

Duration of stop = 25 s.

Braking retardation = 3.2 kmphs.

$$\begin{aligned}\text{Schedule time} &= \frac{D}{V_s} \\ &= \frac{2}{32} \times 60 \times 60 = 225 \text{ s.}\end{aligned}$$

$$\text{Actual time of run } T = 225 - 25 = 200 \text{ s.}$$

$$\begin{aligned}\text{Average speed, } V_a &= \frac{3,600 \times D}{T} \\ &= \frac{3,600 \times 2}{200} \\ &= 36 \text{ kmph.}\end{aligned}$$

$$\begin{aligned}\text{Maximum speed, } (V_m) &= 1.2 V_a \\ &= 1.2 \times 36 \\ V_m &= 43.2 \text{ kmph}\end{aligned}$$

$$\therefore V_m^2 \left(\frac{1}{2\alpha} + \frac{1}{2\beta} \right) - V_m T + 3,600$$

$$\begin{aligned}\frac{1}{2\alpha} + \frac{1}{2\beta} &= \frac{V_m T - 3,600 \times D}{V_m^2} \\ &= \frac{43.2 \times 200 - 3,600 \times 2}{(43.2)^2}\end{aligned}$$

$$\frac{1}{2\alpha} + \frac{1}{2\beta} = 0.7716$$

$$\frac{1}{2\alpha} = 0.716 - \frac{1}{2 \times 3.2}$$

$$\frac{1}{2\alpha} = 0.61535$$

$$\alpha = 0.893 \text{ kmphps.}$$

Example 10.7: A suburban electric train has a maximum speed of 75 kmph. The schedule speed including a station stop of 25 s is 48 kmph. If the acceleration is 2 kmphps, the average distance between two stops is 4 km. Determine the value of retardation.

Solution:

Maximum speed $V_m = 75$ kmph.

The distance of run (D) = 4 km.

Schedule speed (V_s) = 48 kmph.

Acceleration (α) = 2 kmphs.

The duration of stop = 25 s.

$$\begin{aligned}\text{Schedule time } (T_s) &= \frac{D}{V_s} \\ &= \frac{4}{48} \times 60 \times 60 = 300 \text{ s.}\end{aligned}$$

$$\therefore V_m^2 \left(\frac{1}{2\alpha} + \frac{1}{2\beta} \right) - V_m T + 3,600 \times D = 0$$

$$\frac{1}{2\alpha} + \frac{1}{2\beta} = \frac{V_m T - 3,600 D}{V_m^2}$$

$$\frac{1}{2 \times 2} + \frac{1}{2\beta} = \frac{75 \times 275 - 3,600 \times 4}{(75)^2}$$

$$0.25 + \frac{1}{2\beta} = 1.1066$$

$$\beta = 0.5836 \text{ kmphs.}$$

Example 10.8: An electric train is accelerated at 2 kmphs and is braked at 3 kmphs. The train has an average speed of 50 kmph on a level track of 2,000 min between the two stations. Determine the following:

1. Actual time of run.
2. Maximum speed.
3. The distance travelled before applying brakes
4. Schedule speed.

Assume time for stop as 12 s. And, run according to trapezoidal.

Solution:

Acceleration (α) = 2 kmphs.

Retardation (β) = 3 kmphs.

Average speed (V_a) = 50 kmph.

Distance $D = 2,000 \text{ min} = 2 \text{ km}$.

The duration of stop = 12 s.

$$\begin{aligned} \text{(i) Time of run } T &= \frac{D}{V_a} \\ &= \frac{2}{50} \times 60 \times 60 = 144 \text{ s.} \end{aligned}$$

$$\text{(ii) Maximum speed, } V_m = \frac{T}{2X} - \sqrt{\frac{T^2}{4X^2} - \frac{3,600D}{X}},$$

where

$$\begin{aligned} X &= \frac{1}{2\alpha} + \frac{1}{2\beta} \\ &= \frac{1}{2 \times 2} + \frac{1}{2 \times 3} \\ &= 0.4166. \end{aligned}$$

$$\begin{aligned} \therefore V_m &= \frac{144}{2 \times 0.4166} - \sqrt{\frac{(144)^2}{4 \times (0.4166)^2} - \frac{3,600 \times 2}{0.4166}} \\ &= 172.8276 - \sqrt{(29,869.397) - (17,282.765)} \\ &= 60.63744 \text{ kmph.} \end{aligned}$$

$$\begin{aligned} \text{(iii) } t_3 &= \frac{V_m}{\beta} = \frac{60.63744}{3} \\ &= 20.2148 \text{ s.} \end{aligned}$$

$$\begin{aligned} D_3 &= \frac{1}{2} V_m t_3 \\ &= \frac{1}{2} \times 60.63744 \times \frac{20.2148}{60 \times 60} = 0.173 \text{ km.} \end{aligned}$$

The distance travelled before applying brakes

$$D_1 + D_2 = D - D_3$$

$$= 2 - 0.17 = 1.83 \text{ km.}$$

$$\begin{aligned} \text{(iv) Schedule speed } V_s &= \frac{D}{T + T_{\text{stop}}} \\ &= \frac{2}{\frac{144 + 12}{60 \times 60}} = 46.153 \text{ kmph.} \end{aligned}$$

Example 10.9: An electric train has an average speed of 40 kmph on a level track between stops 1,500 m apart. It is accelerated at 2 kmphs and is braked at 3 kmphs. Draw the speed–time curve for the run.

Solution:

Average speed $V_a = 40$ kmph.

The distance of run (D) = 1,500 m = 1.5 km.

Acceleration (α) = 2 kmphs.

Retroaction (β) = 3 kmphs.

$$\begin{aligned} \text{The time of run } T &= \frac{D}{V_a} \\ &= \frac{1.5}{40} \times 60 \times 60 = 135 \text{ s.} \end{aligned}$$

Using the equation (Fig. P.10.1):

$$V_m = \frac{T}{2X} - \sqrt{\frac{T^2}{4X^2} - \frac{3,600D}{X}},$$

where

$$X = \frac{1}{2\alpha} + \frac{1}{2\beta}$$

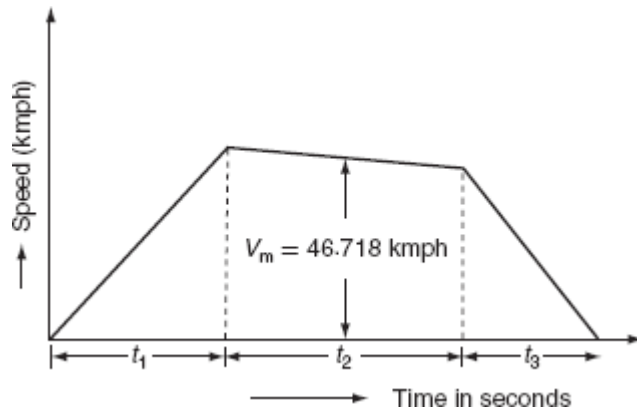

Fig. P.10.1

$$= \frac{1}{2 \times 2} + \frac{1}{2 \times 3} = 0.416.$$

$$\begin{aligned} \therefore V_m &= \frac{135}{2 \times 0.416} - \sqrt{\frac{(135)^2}{4 \times (0.416)^2} - \frac{3600 \times 1.5}{0.416}} \\ &= 162.25 - \sqrt{(2,632 - 8.182) - (12,980.769)} \\ &= 46.718 \text{ kmph.} \end{aligned}$$

$$\begin{aligned} \text{Acceleration period, } t_1 &= \frac{V_m}{\alpha} \\ &= \frac{46.718}{2} \\ t_1 &= 23.359 \text{ s.} \end{aligned}$$

$$\begin{aligned} \text{Braking period, } t_3 &= \frac{V_m}{\beta} \\ &= \frac{46.718}{3} = 15.572. \end{aligned}$$

$$\begin{aligned} \text{Free-running period, } t_2 &= T - (t_1 + t_3) \\ &= 135 - (23.359 + 15.572) \\ &= 96.069. \end{aligned}$$

Example 10.10: An electric train has quadrilateral speed–time curve as follows:

1. Uniform acceleration from rest at 1.5 kmphps for 25 s.
2. Coasting for 45 s.
3. The duration of braking 20 s.

If the train is moving a uniform up gradient of 1.5%, the reactive resistance is 45 N/ton, the rotational inertia effect is 10% of dead weight, the duration of stop is 15 s, and the overall efficiency of transmission gear and motor is 80%. Find schedule speed.

Solution:

Time for acceleration $t_1 = 25$ s.

Time for coasting $t_2 = 45$ s.

Time for braking $t_3 = 20$ s.

Acceleration (α) = 1.5 kmphps.

Maximum speed $V_m = \alpha t_1$

$$= 1.5 \times 25 = 37.5 \text{ kmph.}$$

According to the equation:

$$F_t = 277.8 W_e (-\beta_c) + 98.1 WG + Wf$$

$$0 = -277.8 \times 1.1 W \beta_c + 98.1 \times 1.5 \times W + 45 \times W$$

$$= -305.58 W \beta_c + 147.15 W + 45 W$$

$$30.58 W \beta_c = 192.15 W$$

$$\beta_c = \frac{192.15 W}{305.58 W}$$

$$\beta_c = 0.628 \text{ kmphps.}$$

The speed at the end of coating period $V_2 = V_m - \beta_c t_2$

$$= 37.5 - 0.628 \times 45$$

$$= 9.24 \text{ kmph.}$$

The braking retardation $\beta = \frac{V_2}{t_3}$

$$= \frac{9.24}{20} = 0.462 \text{ kmphps.}$$

The distance travelled $D = \frac{V_m t_1}{7,200} + \frac{(V_m + V_2) t_2}{7,200} + \frac{V_2 t_3}{7,200}$

$$= \frac{37.5 \times 25}{7,200} + \frac{(37.5 + 9.24) \times 45}{7,200} + \frac{9.24 \times 20}{7,200}$$

$$= 0.13 + 0.292 + 0.0256$$

$$= 0.4475 \text{ km.}$$

The schedule time $T_s = t_1 + t_2 + t_3 + \text{duration of stop}$

$$= 25 + 45 + 20 + 15$$

$$= 105 \text{ s.}$$

The schedule speed $V_s = \frac{3,600 \times D}{T_s}$

$$= \frac{3,600 \times 0.4476}{105}$$

$$V_s = 15.346 \text{ kmph.}$$

TRACTIVE EFFORT (FT)

It is the effective force acting on the wheel of locomotive, necessary to propel the train is known as '*tractive effort*'. It is denoted with the symbol F_t . The tractive effort is a vector quantity always acting tangential to the wheel of a locomotive. It is measured in newton.

The net effective force or the total tractive effort (F_t) on the wheel of a locomotive or a train to run on the track is equals to the sum of tractive effort:

1. Required for linear and angular acceleration (F_a).
2. To overcome the effect of gravity (F_g).
3. To overcome the frictional resistance to the motion of the train (F_r).

$$\therefore F_t = F_a + F_g + F_r \quad (10.8)$$

Mechanics of train movement

The essential driving mechanism of an electric locomotive is shown in [Fig. 10.6](#). The electric locomotive consists of pinion and gear wheel meshed with the traction motor and the wheel of the locomotive. Here, the gear wheel transfers the tractive effort at the edge of the pinion to the driving wheel.

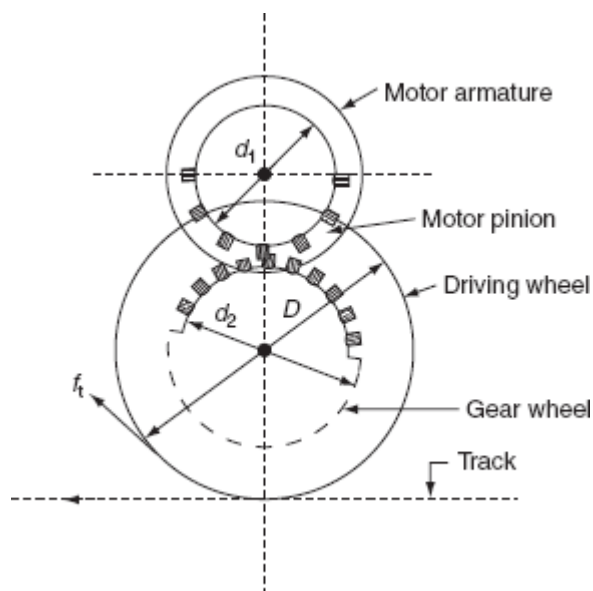

Fig. Driving mechanism of electric locomotives

Let T is the torque exerted by the motor in N-m, F_p is tractive effort at the edge of the pinion in Newton, F_t is the tractive effort at the wheel, D is the diameter of

the driving wheel, d_1 and d_2 are the diameter of pinion and gear wheel, respectively, and η is the efficiency of the power transmission for the motor to the driving axle.

Now, the torque developed by the motor $T = F_p \times \frac{d_1}{2}$ N-m.

$$\therefore F_p = \frac{2T}{d_1} \text{ N.} \quad (10.9)$$

The tractive effort at the edge of the pinion transferred to the wheel of locomotive is:

$$F_t = F_p \times \frac{d_2}{D} \text{ N.} \quad (10.10)$$

$$\begin{aligned} \text{From Equations (10.9) and (10.10) } F_t &= \eta \times \frac{2T}{d_1} \times \frac{d_2}{D} \\ &= \eta \cdot T \cdot \frac{2}{D} \left(\frac{d_2}{d_1} \right) \\ &= \eta T \cdot \frac{2}{D} \cdot r, \end{aligned}$$

where ' r ' = $\left(\frac{d_2}{d_1} \right)$ is known as gear ratio.

$$\therefore F_t = 2\eta r \frac{T}{D} \text{ N.} \quad (10.11)$$

10.7.2 Tractive effort required for propulsion of train

From Equation (10.8), the tractive effort required for train propulsion is:

$$F_t = F_a + F_g + F_r,$$

where F_a is the force required for linear and angular acceleration, F_g is the force required to overcome the gravity, and F_r is the force required to overcome the resistance to the motion.

Force required for linear and angular acceleration (F_a)

According to the fundamental law of acceleration, the force required to accelerate the motion of the body is given by:

Force = Mass \times acceleration

$$F = ma.$$

Let the weight of train be ‘ W ’ tons being accelerated at ‘ α ’ kmphs:

\therefore The mass of train $m = 1,000 W$ kg.

And, the acceleration = α kmphs

$$= \alpha \times \frac{1,000}{3,600} \text{ m/s}^2$$

$$= 0.2778\alpha \text{ m/s}^2.$$

The tractive effort required for linear acceleration:

$$\begin{aligned} F_a &= 1,000 W \text{ kg} \times 0.2778\alpha \text{ m/s}^2 \\ &= 27.78 W\alpha \text{ kg} - \text{m/s}^2 \text{ (or) N.} \end{aligned} \quad (10.12)$$

Equation (10.12) holds good only if the accelerating body has no rotating parts. Owing to the fact that the train has rotating parts such as motor armature, wheels, axels, and gear system. The weight of the body being accelerated including the rotating parts is known as *effective weight* or *accelerating weight*. It is denoted with ‘ W_e ’. The accelerating weight ‘(W_e)’ is much higher (about 8–15%) than the dead weight (W) of the train. Hence, these parts need to be given angular acceleration at the same time as the whole train is accelerated in linear direction.

\therefore The tractive effort required-for linear and angular acceleration is:

$$F_a = 27.88 W_e \alpha \text{ N.} \quad (10.13)$$

Tractive effort required to overcome the train resistance (F_r)

When the train is running at uniform speed on a level track, it has to overcome the opposing force due to the surface friction, i.e., the friction at various parts of the rolling stock, the friction at the track, and also due to the wind resistance. The magnitude of the frictional resistance depends upon the shape, size, and condition of the track and the velocity of the train, etc.

Let ' r ' is the specific train resistance in N/ton of the dead weight and ' W ' is the dead weight in ton.

∴ The tractive effort required to overcome the train resistance $F_r = Wr$ N. (10.14)

Tractive effort required to overcome the effect of gravity (F_g)

When the train is moving on up gradient as shown in Fig. 10.7, the gravity component of the dead weight opposes the motion of the train in upward direction. In order to prevent this opposition, the tractive effort should be acting in upward direction.

∴ The tractive effort required to overcome the effect of gravity:

$$\begin{aligned} F_g &= \pm mg \sin\theta \text{ N} \\ &= \pm 1,000 Wg \sin\theta \quad [\because m = 1,000 W\text{kg}]. \end{aligned} \quad (10.15)$$

Now, from the Fig. 10.7:

$$\text{Gradient} = \sin\theta = \frac{BC}{AC} = \frac{\text{Elevation}}{\text{distance along the track}}$$

$$\% \text{ Gradient } G = \sin\theta \times 100. \quad (10.16)$$

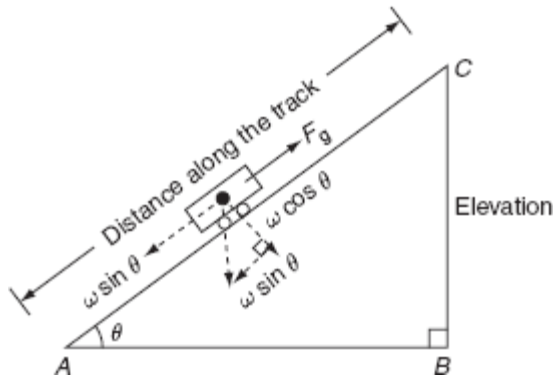

Fig. 10.7 Train moving on up gradient

From Equations (10.15) and (10.16):

$$\begin{aligned}
 \therefore F_g &= \pm 1,000 W g \times \frac{G}{100} \\
 &= \pm 10 \times 9.81 W G \\
 &= \pm 98.1 W G N \quad \quad \quad [\text{since } g = 9.81 \text{ m/s}^2]. \quad (10.17)
 \end{aligned}$$

+ve sign for the train is moving on up gradient.

–ve sign for the train is moving on down gradient.

This is due to when the train is moving on a gradient, the tractive effort showing Equation (10.17) will be required to oppose the force due to gravitational force, but while going down the gradient, the same force will be added to the total tractive effort.

\therefore The total tractive effort required for the propulsion of train $F_t = F_a + F_r \pm F_g$:

$$F_t = 277.8 W_e \alpha + W r \pm 98.1 W G N. \quad (10.18)$$

Power output from the driving axle

Let F_t is the tractive effort in N and v is the speed of train in kmph.

∴ The power output (P) = rate of work done

$$\begin{aligned} &= \text{Tractive effort} \times \frac{\text{distance}}{\text{time}} \\ &= \text{Tractive effort} \times \text{speed} \\ &= \frac{F_t \times v \times 1,000}{3,600} \text{ W} \\ &= \frac{F_t \times v}{3,600} \text{ kW.} \end{aligned} \quad (10.19)$$

If ' v ' is in m/s, then $P = F_t \times v$ W.

If ' η ' is the efficiency of the gear transmission, then the power output of motors, $P = \frac{F_t v}{\eta}$ W:

$$= \frac{F_t v}{3,600 \eta} \text{ kW.} \quad (10.20)$$

SPECIFIC ENERGY CONSUMPTION

The energy input to the motors is called the *energy consumption*. This is the energy consumed by various parts of the train for its propulsion. The energy drawn from the distribution system should be equals to the energy consumed by the various parts of the train and the quantity of the energy required for lighting, heating, control, and braking. This quantity of energy consumed by the various parts of train per ton per kilometer is known as specific energy consumption. It is expressed in watt hours per ton per km.

$$\therefore \left. \begin{array}{l} \text{Specific energy} \\ \text{consumption} \end{array} \right\} = \frac{\text{total energy consumption in W-h}}{\text{the weight of the train in tons} \times \text{the distance covered by train in km}}$$

Determination of specific energy output from simplified speed–time curve

Energy output is the energy required for the propulsion of a train or vehicle is mainly for accelerating the rest to velocity ‘ V_m ’, which is the energy required to overcome the gradient and track resistance to motion.

Energy required for accelerating the train from rest to its crest speed ‘ V_m ’

The energy required for accelerating the train = power \times time

$$\begin{aligned} &= \frac{\text{work done}}{\text{time}} \times \text{time} \\ &= \text{tractive effort} \times \text{velocity} \times \text{time} \\ &= F_t \times \frac{V_m}{3,600} \times t_1 \text{ N-km/h-sec} \\ &= F_t \times \frac{1}{2} \times \frac{V_m}{3,200} \times \frac{t_1}{3,600} \text{ N-km (or) kW-hr} \\ &= \frac{1}{2} \times \frac{V_m^2}{(3,600)^2} F_t \text{ kW-hr} \left[\because t_1 = \frac{V_m}{\alpha} \right] \\ &= \frac{1}{2} \times \frac{V_m^2}{(3,600)^2} \alpha [277.8W_e \alpha + 98.1 WG + Wr] \text{ kW-hr.} \\ &[\because F_t = 277.8W_e \alpha + 98.1 WG + Wr]. \end{aligned}$$

Energy required for overcoming the gradient and tracking resistance to motion

Energy required for overcoming the gradient and tracking resistance:

$$\begin{aligned} &= \text{tractive effort} \times \text{velocity} \times \text{time} \\ &= F_t' \times \frac{V_m}{3,600} \times \frac{t_2}{3,600} \text{ kW-hr} \\ &= \frac{V_m t_2}{(3,600)^2} [Wr + 98.1 WG] \text{ kW-hr,} \end{aligned}$$

where F_t' is the tractive effort required to overcome the gradient and track resistance, W is the dead weight of train, r is the track resistance, and G is the percentage gradient.

Total energy output = energy required for acceleration + energy required to overcome gradient and to resistance to motion.

$$\begin{aligned}
 &= \frac{V_m^2}{2(3,600)^2 \alpha} [277.8 W_e \alpha + 98.1 WG + Wr] + \frac{V_m t_2}{(3,600)^2} [Wr + 98.1 WG] \text{ kW-hr} \\
 &= \frac{V_m^2 (1,000)}{2(3,600)^2 \alpha} [277.8 W_e \alpha + 98.1 WG + Wr] + \frac{V_m t_2 \times 1,000}{(3,600)^2} [Wr + 98.1 WG] \text{ W-hr} \\
 &= \frac{V_m^2 (1,000)}{2\alpha (3,600)^2} [27.8 W_e \alpha] + \left[\frac{V_m^2 (1,000)}{2\alpha (3,600)^2} + \frac{V_m t_2 \times 1,000}{(3,600)^2} \right] [Wr + 98.1 WG] \text{ W-hr} \\
 &= 0.01072 W_e V_m^2 + \frac{1,000}{(3,600)} [Wr + 98.1 WG] \left[\frac{V_m^2}{2\alpha 3,600} + \frac{V_m t_2}{3,600} \right] \text{ W-hr} \\
 &= 0.01072 W_e V_m^2 + 0.2778 [Wr + 98.1 WG] [D_1 + D_2] \text{ W-hr,}
 \end{aligned}$$

$$\text{where } D_1 = \frac{V_m^2}{2\alpha 3,600} = \frac{V_m^2}{7,200\alpha}.$$

$$D_2 = \frac{V_m t_2}{3,600}.$$

$$\therefore \text{ The specific energy output} = \frac{\text{energy output in Whr}}{\text{weight of train in tons} \times \text{distance of running}}$$

$$= \frac{0.001072V_m^2 W_e + 0.2778[98.1WG + Wr][D_1 + D_2]}{W \times D}$$

$$= \frac{0.001072V_m^2}{D} \left[\frac{W_e}{W} \right] + \left[\frac{98.1G + r}{D} \right] \times 0.2778 \times D'$$

where $D' = D_1 + D_2$.

For uniform level track $G = 0$:

$$\therefore \text{The specific energy output} = \frac{0.001072V_m^2}{D} \frac{W_e}{W} + 0.2778r \times \frac{D'}{D} \text{ W-hr/ton-km.}$$

$$\therefore \text{The specific energy consumption} = \frac{\text{specific energy output}}{\text{efficiency of motors}}$$

$$= \frac{0.001072V_m^2}{\eta D} \frac{W_e}{W} + 0.2778 \frac{D'}{D} \frac{r}{\eta} \text{ W-hr/ton-km.} \quad (10.21)$$

Factors affecting the specific energy consumption

Factors that affect the specific energy consumption are given as follows.

Distance between stations

From equation specific energy consumption is inversely proportional to the distance between stations. Greater the distance between stops is, the lesser will be the specific energy consumption. The typical values of the specific energy consumption is less for the main line service of 20–30 W-hr/ton-km and high for the urban and suburban services of 50–60 W-hr/ton-km.

Acceleration and retardation

For a given schedule speed, the specific energy consumption will accordingly be less for more acceleration and retardation.

Maximum speed

For a given distance between the stops, the specific energy consumption increases with the increase in the speed of train.

Gradient and train resistance

From the specific energy consumption, it is clear that both gradient and train resistance are proportional to the specific energy consumption. Normally, the coefficient of adhesion will be affected by the running of train, parentage gradient,

condition of track, etc. for the wet and greasy track conditions. The value of the coefficient of adhesion is much higher compared to dry and sandy conditions.

IMPORTANT DEFINITIONS

1 Dead weight

It is the total weight of train to be propelled by the locomotive. It is denoted by 'W'.

2 Accelerating weight

It is the effective weight of train that has angular acceleration due to the rotational inertia including the dead weight of the train. It is denoted by 'W_e'.

This effective train is also known as accelerating weight. The effective weight of the train will be more than the dead weight. Normally, it is taken as 5–10% of more than the dead weight.

3 Adhesive weight

The total weight to be carried out on the drive in wheels of a locomotive is known as adhesive weight.

4 Coefficient of adhesion

It is defined as the ratio of the tractive effort required to propel the wheel of a locomotive to its adhesive weight.

$$F_t \propto W$$
$$= \mu W,$$

where F_t is the tractive effort and W is the adhesive weight.

$$\therefore \mu = \frac{F_t}{W} \quad (10.22)$$

Example 10.11: A 250-ton motor coach having four motors each developing 6,000 N-m torque during acceleration, starts from rest. If the gradient is 40 in 1,000, gear ratio is 4, gear transmission efficiency is 87%, wheel radius is 40 cm, train resistance is 50 N/ton, the addition of rotational inertia is 12%. Calculate the time taken to attain a speed of 50 kmph. If the line voltage is 3,000-V DC and the efficiency of motors is 85%. Find the current during notching period.

Solution:

The weight of train $W = 250$ ton.

$$\text{Percentage gradient } G = \frac{40}{1,000} \times 100 = 4\%.$$

Gear ratio $r = 4$.

Wheel diameter $D = 2 \times 40 = 80$ cm.

Or, $D = 0.8$ m.

Train resistance $r = 50$ N/ton.

Rotational inertia = 12%.

Accelerating weight of the train $W_e = 1.10 \times 250 = 275$ ton.

Total torque developed $T = 4 \times 6,000 = 24,000$ Nm.

$$\begin{aligned} \text{Tractive effort } F_t &= \frac{\eta T 2r}{D} \\ &= \frac{0.87 \times 24,000 \times 2 \times 4}{0.8} = 208,800 \text{ N.} \end{aligned}$$

But,

$$F_t = 277.8 W_e \alpha + 98.1 WG + Wr$$

$$208,800 = 277.8 \times 275 \alpha + 98.1 \times 250 \times 4 + 250 \times 50$$

$$\therefore \alpha = 1.285 \text{ kmphs.}$$

The time taken for the train to attain the speed of 50 kmph:

$$t = \frac{V_m}{\alpha}$$
$$= \frac{50}{1.285} = 38.89 \text{ s.}$$

Power output from the driving axles:

$$= \frac{F_t \times V_m}{3,600} = \frac{208,800 \times 50}{3,600}$$
$$= 2,900 \text{ kW.}$$

$$\text{Power input} = \frac{\text{power output}}{\eta_m}$$
$$= \frac{2,900}{0.85} = 3,411.76 \text{ kW.}$$

$$\text{Total current drawn} = \frac{\text{power input}}{V}$$
$$= \frac{3,411.76 \times 10^3}{3,000} = 1,137.25 \text{ A.}$$

$$\text{Current drawn by the each motor} = \frac{1,137.25}{4} = 284.31 \text{ A.}$$

Example 10.12: An electric train of weight 250 ton has eight motors geared to driving wheels, each is 85 cm diameter. The tractive resistance is of 50/ton. The effect of rotational inertia is 8% of the train weight, the gear ratio is 4–1, and the gearing efficiency is 85% determine. The torque developed by each motor to accelerate the train to a speed of 50 kmph in 30 s up a gradient of 1 in 200.

Solution:

The weight of train $W = 250$ ton.

The diameter of driving wheel $D = 0.85$ m.

Tractive resistance, $r = 50$ N/ton.

Gear ratio $r = 4$.

Gearing efficiency $\eta = 0.85$.

Accelerating weight of the train:

$$\begin{aligned}W_e &= 1.10 \times W \\ &= 1.10 \times 250 = 275 \text{ ton.}\end{aligned}$$

Maximum speed $V_m = 50$ kmph.

$$\text{Acceleration } \alpha = \frac{V_m}{t_1} = \frac{50}{30} = 1.66 \text{ kmph.}$$

$$\begin{aligned}\text{Tractive effort } F_t &= 277.8 W_e \alpha + 98.1 WG + Wr \\ &= 126,815.7 + 12,262.5 + 12,500 \\ &= 151,578.2 \text{ N.}\end{aligned}$$

$$\begin{aligned}\text{Total torque developed } T &= \frac{F_t \times D}{\eta \times 2\gamma} \\ &= \frac{151,578.2 \times 0.85}{0.85 \times 2 \times 4} \\ &= 18,947.25 \text{ N-m.}\end{aligned}$$

$$\begin{aligned}\text{Torque developed by each motor} &= \frac{18,947.25}{8} \\ &= 2,368.409 \text{ N-m.}\end{aligned}$$

Example 10.13: A tram car is equipped with two motors that are operating in parallel, the resistance in parallel. The resistance of each motor is 0.5Ω . Calculate the current drawn from the supply mains at 450 V when the car is running at a steady-state speed of 45 kmph and each motor is developing a tractive effort of $1,600 \text{ N}$. The friction, windage, and other losses may be assumed as $3,000 \text{ W}$ per motor.

Solution:

The resistance of each motor = 0.5Ω .

Voltage across each motor $V = 450 \text{ V}$.

Tractive effort $F_t = 1,600$ N.

Maximum speed $V_m = 45$ kmph.

Losses per motor = 3,000 W.

$$\begin{aligned}\text{The power output of each motor} &= \frac{F_t \times V_m}{3,600} \\ &= \frac{1,600 \times 45 \times 10^3}{3,600} \\ &= 20,000 \text{ W.}\end{aligned}$$

Copper losses = $I^2 R_m = I^2 \times 0.5$

Motor input = motor output + constant loss + copper losses

$$450 \times I = 20,000 + 3,000 + 0.5I^2$$

$$0.5 I^2 - 450I + 23,000 = 0.$$

After solving, we get $I = 54.39$ A.

$$\begin{aligned}\text{Total current drawn from supply mains} &= 2 \times 54.39 \\ &= 108.78 \text{ A.}\end{aligned}$$

Example 10.14: A locomotive exerts a tractive effort of 35,000 N in halting a train at 50 kmph on the level track. If the motor is to haul the same train on a gradient of 1 in 50 and the tractive effort required is 55,000 N, determine the power delivered by the locomotive if it is driven by (i) DC series motors and (ii) induction motors.

Solution:

Tractive effort $F_t = 35,000$ N.

Maximum speed $V_m = 50$ kmph.

$$\begin{aligned}
 \text{Power output} &= \frac{F_t \times V_m}{3,600} \\
 &= \frac{35,000 \times 50 \times 10^3}{3,600} \\
 &= 486,111.11 \text{ W} \\
 &= 486.11 \text{ kW.}
 \end{aligned}$$

The power delivered by the locomotive on up gradient track with the DC series motors:

$$\begin{aligned}
 &= 486.11 \sqrt{\frac{55,000}{35,000}} \\
 &= 609.37 \text{ kW.}
 \end{aligned}$$

Since the power output $\propto \sqrt{T} \propto \sqrt{F_t}$, the power delivered by the locomotive on up gradient with the induction motors is:

$$\begin{aligned}
 &= 486.11 \times \frac{55,000}{35,000} \\
 &= 763.8875 \text{ W} \quad (\because \text{power output} \propto T \propto F_t).
 \end{aligned}$$

Example 10.15: A train weighting 450 ton has speed reduced by the regenerative braking from 50 to 30 kmph over a distance of 2 km on down gradient of 1.5%. Calculate the electrical energy and the overage power returned to the line tractive resistance is 50 N/ton. And, allow the rotational inertia of 10% and the efficiency conversion 80%.

Solution:

The accelerating weight of the train $W_e = 1.1 W$

$$= 1.1 \times 450 = 495 \text{ ton.}$$

The distance travelled $D = 2$ km.

Gradient $G = 1.5\%$

Track resistance $r = 50$ N/ton.

Efficiency $\eta = 0.8$.

The energy available due to the reduction in the speed is:

$$\begin{aligned} &= 0.01072 W_e V_1^2 - V_2^2 \\ &= 0.1072 \times 495 (50^2 - 30^2) \\ &= 8,490.24 \text{ W-hr} \\ &= 8.49 \text{ kW-hr.} \end{aligned}$$

The tractive effort required while going down the gradient:

$$\begin{aligned} F_t &= Wr - 98.1 WG \\ &= 450 \times 50 - 98.1 \times 450 \times 1.5 \\ &= -43,717.5 \text{ N.} \end{aligned}$$

The energy available while moving down the gradient a distance of 2 km is:

$$\begin{aligned} &\frac{F_t \times D \times 1,000}{1,000 \times 3,600} \text{ kW-hr} \\ &= \frac{43,717.5 \times 2 \times 1,000}{1,000 \times 3,600} \\ &= 24.2875 \text{ kW-hr.} \end{aligned}$$

The total energy available = $8.49 + 24.2875$

$$= 32.7775 \text{ kW-hr.}$$

$$\begin{aligned}\text{The average speed} &= \frac{50 + 30}{2} \\ &= 40 \text{ kmph.}\end{aligned}$$

$$\text{The time taken to cover 2 km} = \frac{2}{40} = \frac{1}{20} \text{ h.}$$

$$\text{The average power} = \frac{\text{Energy returned to the line}}{\text{time}} = \frac{26.222}{1/20} = 524.44 \text{ kW.}$$

Example 10.16: A train weighing 450 ton is going down a gradient of 20 in 1,000, it is desired to maintain train speed at 50 kmph by regenerative braking. Calculate the power fed into the line and allow rotational inertia of 12% and the efficiency of conversion is 80%. Traction resistance is 50 N/ton.

Solution:

The dead weight of train $W = 450 \text{ ton.}$

The maximum speed $V_m = 50 \text{ kmph.}$

$$\text{Gradient } G = \frac{20 \times 100}{1,000} = 2\%.$$

Tractive resistance $r = 50 \text{ N/ton.}$

Rotational inertia = 12%.

The efficiency of conversion = 0.8

The tractive effort required while going down the gradient:

Tractive resistance $r = 50 \text{ N/ton.}$

Rotational inertia = 12%.

The efficiency of conversion = 0.8

The tractive effort required while going down the gradient:

$$= Wr - 98.1 WG$$

$$= 450 \times 50 - 98.1 \times 450 \times 2$$

$$= -65,790 \text{ N.}$$

$$\text{The power available } P = \frac{F_t \times V_m}{3,600}$$

$$= \frac{65,790 \times 50}{3,600}$$

$$= 913.75 \text{ kW.}$$

The power fed into the line = power available \times efficiency of conversion

$$= 913.75 \times 0.8$$

$$= 731 \text{ kW.}$$

Example 10.17: The speed–time curve of an electric train on a uniform raising gradient of 10 in 1,000 comprise of:

1. Uniform acceleration from rest at 2.2 kmphs for 30 s.
2. Wasting with power off for 30 s.
3. Braking at 3.2 kmphs to standstill the weight of the train is 200 ton. The tractive resistance of level track being 4 kg/ton and the allowance for rotary inertia 10%. Calculate the maximum power developed by traction motors and the total distance travelled by the train. Assume the transmission efficiency as 85%.

Solution:

$$\text{Gradient} = \frac{10}{1,000} \times 100 = 1\%.$$

$$\text{Acceleration } (\alpha) = 2.2 \text{ kmphs.}$$

$$\text{Braking } (\beta) = 3.2 \text{ kmph.}$$

$$\text{The dead weight of train } W = 200 \text{ ton.}$$

$$\text{Track resistance } r = 4 \text{ kg/ton} = 4 \times 9.81 = 39.24 \text{ N/ton.}$$

$$\text{Maximum velocity } V_m = \alpha t_1 = 2.2 \times 30 = 66 \text{ kmph.}$$

Tractive effort required:

$$\begin{aligned}
F_t &= 277.8 W_c \alpha + 98.1 WG + Wr \\
&= 277.8 \times 8 \times 1.1 \times 200 \times 2.2 + 98.1 \times 200 \times 1 + 200 \times 39.24 \\
&= 161,923.2 \text{ N.}
\end{aligned}$$

$$\begin{aligned}
\text{The maximum power output} &= \frac{F_t V_m}{3,600} \\
&= \frac{161,923.2 \times 66}{3,600} \\
&= 2,968.592 \text{ kW.}
\end{aligned}$$

$$\text{The maximum power developed by the traction motor} = \frac{2,968.592}{0.85} = 3492.46 \text{ kW.}$$

Let, the coasting retardation be β_c :

$$F_t = 277.8 W_c (-\beta_c) + 98.1 WG + Wr$$

$$0 = -277.8 \times (1.1 \times 200) \times \beta_c + 98.1 \times 200 \times 1 + 200 \times 39.24$$

$$\beta_c = 0.449 \text{ kmphps}$$

$$V_2 = V_m - \beta_c V_2$$

$$= 66 - 0.449 \times 65$$

$$= 36.815 \text{ kmph.}$$

$$\text{Braking period } t_3 = \frac{V_2}{\beta} = \frac{36.815}{3.2} = 11.504 \text{ s.}$$

The total distance travelled by the train:

$$\begin{aligned}
D &= \frac{V_m t_1}{7,200} + \frac{(V_1 + V_2)t_2}{7,200} + \frac{V_2 t_3}{7,200} \\
&= \frac{66 \times 30}{7,200} + \frac{(66 + 36.815) \times 65}{7,200} + \frac{36.815 \times 11.504}{7,200} \\
&= 0.275 + 0.928 + 0.0588 \\
&= 1.26 \text{ km.}
\end{aligned}$$

Example 10.18: A 2,300-ton train proceeds down a gradient of 1 in 100 for 5 min, during which period, its speed gets reduced from 40 to 20 kmph by the application of the regenerative braking. Find the energy returned to the lines if the tractive resistance is 5 kg/ton, the rotational inertia 10%, and the overall efficiency of the motors during regeneration is 80%.

Solution:

The dead weight of the train $W = 2,300$ ton.

The accelerating weight of the train $W_e = 1.1 \times 2,300$ s
 $= 2,530$ ton.

$$\text{Gradient} = \frac{1}{100} \times 100 = 1\%.$$

Tractive resistance $r = 5 \times 9.81 = 49.05$ N/ton.

Regenerative period $t = 5 \times 60$
 $= 300$ s.

Overall efficiency $\eta = 0.8$.

The energy available due to the reduction in speed:

$$\begin{aligned}
&= 0.01072 W_e (V_1^2 - V_2^2) \\
&= 0.01072 \times 2,530 \times (40^2 - 20^2)
\end{aligned}$$

$$= 32,545.92$$

$$= 32.54 \text{ kW-hr.}$$

The tractive effort required while going down the gradient:

$$= Wr - 98.1 WG$$

$$= 2,300 \times 49.05 - 98.1 \times 2,300 \times 1$$

$$= -112,815.$$

The distance moved during regeneration:

$$\begin{aligned} &= \frac{V_1 + V_2}{2} \times \frac{1,000}{3,600} \times t \\ &= \frac{40 + 20}{2} \times \frac{1,000}{3,600} \times 300 \\ &= 2,500 \text{ m.} \end{aligned}$$

The energy available on the account of moving down the gradient over a distance of 2,500 m:

$$\begin{aligned} &= \frac{112,815 \times 2,500}{2,600 \times 1,000} \\ &= 78.34 \text{ kW-hr.} \end{aligned}$$

The total energy available = 32.54 + 78.34

$$= 88.707 \text{ kW-hr.}$$

The energy returned to the line = 0.8 × 11.08

$$= 88.707 \text{ kW-hr.}$$

Example 10.19: An electric train has an average speed of 50 kmph on a level track between stops 1,500 m apart. It is accelerated at 2 kmphs and is braked at 3 kmphs. Estimate the energy consumption at the axle of the train per ton-km. Take the reactive resistance constant at 50 N/ton and allow 10% for rotational inertia.

Solution:

Acceleration (α) = 2 kmphs.

Retardation (β) = 3 kmphs.

The distance of run (D) = 1.5 km.

Average speed V_a = 50 kmph.

$$\begin{aligned}\text{The time of run } T &= \frac{D}{V_a} \times 3,600 \\ &= \frac{1.5}{50} \times 3,600 \\ &= 108 \times 10^3 \text{ s.}\end{aligned}$$

Using the equation:

$$V_m = \frac{T}{2X} - \sqrt{\frac{T^2}{4X^2} - \frac{3,600}{X}}$$

$$X = \frac{1}{2\alpha} + \frac{1}{2\beta}$$

$$= \frac{1}{2 \times 2} + \frac{1}{2 \times 3} = 0.416.$$

$$V_m = \frac{108}{2 \times 0.416} - \sqrt{\frac{(108)^2}{4 \times (0.416)} - \frac{3600 \times 3.5}{0.416}}$$

$$= 129.807 - \sqrt{16850.036 - 1298.769}$$

$$= 67.603 \text{ kmph.}$$

$$\text{Accelerating period, } t_1 = \frac{V_m}{\alpha}$$

$$= \frac{67.603}{2}$$

$$= 33.8015 \text{ s.}$$

$$\text{Braking period, } t_3 = \frac{V_m}{\beta}$$

$$= \frac{67.603}{3}$$

$$= 22.534 \text{ s.}$$

The distance travelled during braking:

$$= \frac{1}{2} \times V_m \times \frac{t_3}{3,600}$$

$$= \frac{1}{2} \times 67.603 \times \frac{22.534}{3,600}$$

$$= 0.2115 \text{ km.}$$

$$D_1 = D - 0.2115$$

$$= 1.5 - 0.2115$$

$$= 1.288 \text{ km.}$$

Tractive resistance $r = 50 \text{ N/ton}$

$$\frac{W_c}{W} = 1.1.$$

The energy consumption at the axle of the train per ton-km:

$$\begin{aligned}
 &= \frac{0.01072V_m^2}{D} \times \frac{W_e}{W} + 0.2778r \frac{D_1}{D} \\
 &= \frac{0.01072 \times (67.603)^2}{1.5} \times 1.1 + 2.778 \times 50 \times \frac{1.288}{1.5} \\
 &= 35.927 + 11.926 \\
 &= 47.853 \text{ W-hr.}
 \end{aligned}$$

Example 10.20: An electric train has quadrilateral speed–time curve as follows.

1. The uniform acceleration for rest at 2.2 kmphs for 30 s.
2. Coasting for 45 s.
3. The braking period of 20 s.

The train is moving in a uniform up gradient of 1%, the tractive resistance is 50 N/ton, the rotational inertia effect 10% of the dead weight the duration of the station stop 20 s and overall efficiency of transmission gear and motor as 80%. Determine the value of is schedule speed and specific energy consumption of run.

Solution:

Time of acceleration $t_1 = 30$ s.

Time of coasting $t_2 = 45$ s.

Time of braking $t_3 = 20$ s.

Acceleration (α) = 2.2 kmphs.

Maximum speed $V_m = \alpha t_1 = 2.2 \times 30 = 66$ kmph.

Gradient $G = 1\%$.

Let the coasting retardation be β_c :

$$F_t = 277.8 W_e(-\beta_c) + 98.1 WG + Wr.$$

$$0 = 277.8 \times 1.1 W \beta_c + 98.1 \times W \times 1 + 50 W$$

$$= -305.58 W \beta_c + 98.1 W + 50 W.$$

$$\beta_c = 0.4846 \text{ kmphps.}$$

$$V_2 = V_m - \beta_c t_2$$

$$= 66 - 0.4846 \times 45$$

$$= 44.193 \text{ kmph.}$$

$$\begin{aligned} \text{Braking retardation, } \beta &= \frac{V_2}{t_3} = \frac{44.193}{20} \\ &= 2.207 \text{ kmphps.} \end{aligned}$$

$$\begin{aligned} \text{The distance travelled } D &= \frac{V_m t_1}{7,200} + \frac{(V_m + V_2)t_2}{7,200} + \frac{V_2 t_3}{7,200} \\ &= \frac{66 \times 30}{7,200} + \frac{(66 + 44.193)}{7,200} \times 45 + \frac{44.193 \times 20}{7,200} \\ &= 0.275 + 0.688 + 0.122 \\ &= 1.085 \text{ km.} \end{aligned}$$

$$\begin{aligned} \text{Schedule time, } T_s &= t_1 + t_2 + t_3 + \text{stop duration} \\ &= 30 + 45 + 20 + 20 \\ &= 115 \text{ s.} \end{aligned}$$

$$\begin{aligned} \text{Schedule speed, } V_s &= \frac{3,600 \times D}{T_s} \\ &= \frac{3,600 \times 1.085}{115} \\ &= 33.965 \text{ kmph.} \end{aligned}$$

When power is on, the distance travelled is:

D_1 = distance travelled during acceleration period

$$\begin{aligned}
&= \frac{V_m t_1}{7,200} \\
&= \frac{66 \times 30}{7,200} = 0.275 \text{ km.}
\end{aligned}$$

The specific energy output:

$$\begin{aligned}
&= \frac{0.01072 V_m^2}{D} \times \frac{W_e}{W} + 0.2778(98.1G + r) \frac{D_1}{D} \\
&= \frac{0.01072 \times 66^2}{1.085} \times 1.1 + 0.2778(98.1 \times 1 + 50) \times \frac{0.275}{1.085} \\
&= 47.341 + 10.427 \\
&= 57.768 \text{ W-hr/ton-km.}
\end{aligned}$$

$$\begin{aligned}
\text{The specific energy consumption} &= \frac{57.768}{0.8} \\
&= 72.21 \text{ W-hr/ton-km.}
\end{aligned}$$

Example 10.21: A train weighing 200-ton accelerates uniformly from rest to a speed of 40 kmph up a gradient of 1 in 100, the time taken being 30 s. The power is then cut off and train coasts down a uniform gradient of 1 in 1,000 for period of 40 s. When brakes are applied for period of 20 s so as to bring the train uniformly to rest on this gradient determine:

1. The maximum power output from the driving axles.
2. The energy taken from the conductor rails in kW-hr assuming an efficiency of 70% assume tractive resistance to be 45 N/ton at all speeds and allow 10% for rotational inertia.

Solution:

$$\begin{aligned}
\text{Accelerating weight, } W_e &= 1.1 \times 200 \\
&= 220 \text{ ton.}
\end{aligned}$$

$$\text{Tractive resistance, } r = 45 \text{ N/ton}$$

$$\begin{aligned}
\text{Gradient} &= \frac{1}{100} \times 100 \\
&= 1\%.
\end{aligned}$$

Maximum speed $V_m = 40$ kmph.

Accelerating period $t_1 = 30$ s.

$$\begin{aligned}\text{Acceleration } \alpha &= \frac{V_m}{t_1} \\ &= \frac{40}{30} \\ &= 1.33 \text{ kmphps.}\end{aligned}$$

Tractive effort required:

$$\begin{aligned}F_t &= 27.88 W_e \alpha + 98.1 WG + Wr \\ &= 277.8 \times 220 \times 1.33 + 98.1 \times 200 \times 1 + 200 \times 45 \\ &= 109,904.28 \text{ N.}\end{aligned}$$

1. The maximum power output from driving axle:

$$\begin{aligned}&= \frac{F_t \times V_m}{3,600} \\ &= \frac{109,904 \times 40}{3,600} \\ &= 1,221.155 \text{ kW.}\end{aligned}$$

Total energy required for the run:

$$\begin{aligned}&= \frac{1}{2} \times \frac{F_t V_m}{3,600} \times \frac{t_1}{3,600} \\ &= \frac{1}{2} \times \frac{109,904 \times 40}{3,600} \times \frac{30}{3,600} \\ &= 5.088 \text{ kW-hr.}\end{aligned}$$

The energy taken for conductor rails $= \frac{5.088}{0.7}$

2. $= 7.268 \text{ kW-hr.}$

Example 10.22: Calculate the energy consumption if a maximum speed of 12 m/sec and for a given run of 1,500 m, an acceleration of 0.36 m/s² desired. The tractive resistance during acceleration is 0.052 N/kg and during the coasting is 6.12

N/1,000 kg. Allow a 10% of rotational inertia, the efficiency of the equipment during the acceleration period is 60%. Assume quadrilateral speed–time curve.

Solution:

Accelerating weight of the train $W_e = 1.1 W$.

Maximum speed $V_m = 12$ m/s.

The distance of run $D = 1,500$ m.

Acceleration $\alpha = 0.36$ m/s².

$$\begin{aligned}\text{Accelerating period } t_1 &= \frac{V_m}{\alpha} \\ &= \frac{12}{0.36} \\ &= 33.33 \text{ s.}\end{aligned}$$

The tractive resistance during acceleration $r = 0.52$ N/kg. The

tractive effort required during acceleration $F_t = W_e\alpha + Wr$

$$= 1.1 W \times 0.36 + W \times 0.052$$

$$= 0.448 W \text{ N.}$$

The total energy required for the run = average power during acceleration \times accelerating period

$$\begin{aligned}
 &= \frac{1}{2} F_r V_m \times t_1 \\
 &= \frac{1}{2} \times 0.448 \times 12 \times 33.3 \\
 &= 89.51 \text{ J} \\
 &= \frac{89.51}{3,600} \\
 &= 0.024 \text{ W-hr.}
 \end{aligned}$$

$$\begin{aligned}
 \text{Specific energy output} &= \frac{\text{energy required for the run}}{W \times D} \\
 &= \frac{0.024 \text{ W}}{W \times 1,500} \\
 &= 1.712 \times 10^{-5} \text{ W-hr/kg-m.}
 \end{aligned}$$

$$\begin{aligned}
 \text{Specific energy consumption} &= \frac{\text{specific energy output}}{\eta} \\
 &= \frac{1.713 \times 10^{-5}}{0.6} \\
 &= 2.85 \times 10^{-5} \text{ W-hr/kg-m.}
 \end{aligned}$$

Example 10.23: A 100-ton weight train has a rotational inertia of 10%. This train has to be run between two stations that are 3 km apart and has an average speed of 50 km/hr. The acceleration and the retardation during braking are 2 kmphps and 3 kmphps, respectively. The percentage gradient between these two stations is 1% and the train is to move up the incline the track resistance is 50 N/ton, then determine:

1. Maximum power at the driving axle.
2. Total energy consumption.
3. Specific energy consumption.

The combined efficiency of the alembic train is 70%. Assume simplified trapezoidal speed–time curve.

Solution:

The dead weight of the train, $W = 100$ ton.

The accelerating weight of the train, $W_e = 1.1 \times W = 1.1 \times 100 = 110$ ton.

The distance of run (D) = 3 km.

Average speed $V_a = 50$ kmph.

Acceleration (α) = 2 kmphps.

Retardation (β) = 3 kmphps.

Gradient (G) = 1%.

Tractive resistance $r = 50$ N/ton.

$$\begin{aligned}\text{Duration of run} &= \frac{3,600 \times D}{V_a} \\ &= \frac{3,600 \times 3}{50} = 216 \text{ km,}\end{aligned}$$

$$\text{where } X = \frac{1}{2\alpha} + \frac{1}{2\beta} = \frac{1}{2 \times 2} + \frac{1}{2 \times 3} = 0.416.$$

Using the equation, the maximum speed:

$$\begin{aligned}
 V_m &= \frac{T}{2X} - \sqrt{\frac{T^2}{4X^2} - \frac{3,600D}{X}} \\
 &= \frac{216}{2 \times 0.416} - \sqrt{\frac{(216)^2}{4 \times (0.416)^2} - \frac{3,600 \times 3}{0.416}} \\
 &= 259.615 - \sqrt{(67,400.147) - (25,961.538)} \\
 &= 56.05 \text{ kmph.}
 \end{aligned}$$

$$\begin{aligned}
 \text{Accelerating period, } t_1 &= \frac{V_m}{\alpha} \\
 &= \frac{56.05}{2} \\
 &= 28.025 \text{ s.}
 \end{aligned}$$

$$\begin{aligned}
 \text{Braking period } t_3 &= \frac{V_m}{\beta} \\
 &= \frac{56.05}{3} \\
 &= 18.683 \text{ s.}
 \end{aligned}$$

$$\begin{aligned}
 \text{Free-running period } t_2 &= 216 - (28.025 + 18.683) \\
 &= 169.292 \text{ s.}
 \end{aligned}$$

$$\begin{aligned}
 \text{Tractive effort required } F_t &= 278 W_e \alpha + 98.1 WG + Wr \\
 &= 277.8 \times 110 \times 2 + 98.1 \times 100 \times 1 + 100 \times 50 \\
 &= 75,926 \text{ N.}
 \end{aligned}$$

(i) Maximum power at the driving axle:

$$\begin{aligned}
 &= \frac{F_t \times V_m}{3,600} \\
 &= \frac{75,926 \times 56.05}{3,600} \\
 &= 1,182.125 \text{ kW.}
 \end{aligned}$$

Tractive effort required during free running is F_t^1 :

$$\begin{aligned}
 F_t^1 &= 98.1 WG + Wr \\
 &= 98.1 \times 100 \times 1 + 100 \times 50 \\
 &= 14,810 \text{ N.}
 \end{aligned}$$

$$\begin{aligned}
 \text{Total energy output} &= \frac{1}{2} F_t \times \frac{V_m}{3,600} \times \frac{t_1}{3,600} + \frac{F_t \times V_m}{3,600} \times \frac{t_2}{3,600} \\
 &= \frac{1}{2} \times 75,926 \times \frac{56.05}{3,600} \times \frac{28.025}{3,600} + \frac{14,810 \times 56.05}{3,600} \times \frac{169.292}{3,600} \\
 &= 4.6 + 10.843 \\
 &= 15.44 \text{ kW-hr.}
 \end{aligned}$$

$$\begin{aligned}
 \text{(ii) Total energy consumption} &= \frac{15.44}{0.70} \\
 &= 22.06 \text{ kW-hr.}
 \end{aligned}$$

$$\begin{aligned}
 \text{(iii) Specific energy consumption} &= \frac{\text{the total energy consumption in watt – hours}}{\text{the weight of the train in tons} \times \text{the distance of the run in km}} \\
 &= \frac{22.06 \times 1000}{100 \times 3} \\
 &= 73.53 \text{ W-h/ton-km.}
 \end{aligned}$$

Example 10.24: An electric train has quadrilateral speed–time curve as follows:

1. Uniform acceleration from rest 2 kmphps for 30 s.
2. Coasting for 40 s.
3. Braking period of 25 s.

The train is moving a uniform down gradient of 1% and the tractive resistance of 50 N/ton. The rotational resistance is 10% of the dead weight, the duration of the stop is 20 s and the overall efficiency of the transmission the gear and the motor as 80%. Calculate its schedule speed and specific energy consumption.

Solution:

Acceleration (α) = 2 kmphps.

Acceleration period (t_1) = 30 s.

Gradient (G) = 1%.

The tractive of resistance (r) = 50 N/ton.

The duration of stop = 20 s.

Overall efficiency (η) = 80%.

Maximum speed $V_m = \alpha t_1$

$$= 2 \times 30 = 60 \text{ kmph.}$$

Let the coasting retardation be β_c :

Tractive effort:

$$F_t = 277.8 W_c (-\beta_c) - 98.1 \times WG + Wr$$

$$0 = -277.8 \times 1.1 W \beta_c - 98.1 \times W \times 1 + 50 W$$

$$\beta_c = \frac{-48.1W}{305.58}$$

$$\beta_c = -0.157 \text{ kmphs}$$

$$V_2 = V_m - \beta_c t_2$$

$$= 60 - (-0.517 \times 40)$$

$$= 66.28 \text{ kmph.}$$

$$\begin{aligned} \text{The distance travelled, } D &= \frac{V_1 t_1}{7,200} + \frac{(V_m + V_2) t_2}{7,200} + \frac{V_2 t_3}{7,200} \\ &= \frac{60 \times 30}{7,200} + \frac{(60 + 66.28)}{7,200} \times 40 + \frac{66.28 \times 25}{7,200} \\ &= 0.25 + 0.7 + 0.23 \\ &= 1.18 \text{ km.} \end{aligned}$$

$$\begin{aligned} \text{Schedule time, } T_s &= t_1 + t_2 + t_3 + \text{stop duration} \\ &= 30 + 40 + 25 + 20 \\ &= 115 \text{ s.} \end{aligned}$$

$$\begin{aligned} \text{Schedule speed, } V_s &= \frac{3,600 \times D}{T_s} \\ &= \frac{3,600 \times 1.18}{115} \\ &= 36.939 \text{ kmph.} \end{aligned}$$

The specific energy output:

$$\begin{aligned}
 &= \frac{0.01072 V_m^2}{D} \times \frac{W_e}{W} + 0.2778(98.1 G + r) \frac{D_1}{D} \\
 &= \frac{0.01072 \times (60)^2}{1.18} \times 1.1 + 0.2778(98.1 \times 1 + 50) \times \frac{0.25}{1.18} \\
 &= 35.975 + 8.716 \\
 &= 44.69 \text{ W-hr/ton-km.} \\
 \text{The specific energy consumption} &= \frac{44.69}{0.8} = 55.86 \text{ W-hr/ton-km.}
 \end{aligned}$$

Example 10.25: The schedule speed of a electric train is 40 kmph. The distance between two stations is 3 km with each stop is of 30 s duration. Assuming the acceleration and the retardation to be 2 and 3 kmphs, respectively. The dead weight of the train is 20 ton. Assume the rotational inertia is 10% to the dead weight and the track resistance is 40 N/ton. Calculate:

1. The maximum speed.
2. The maximum power output from driving axles.
3. The specific energy consumption is watt-hours per ton-km. The overall efficiency is 80%, assume simplified speed–time curve.

Solution:

Schedule speed $V_s = 40$ kmph.

The distance between the two stations (D) = 3 km.

The duration of stop = 30 s.

Acceleration (α) = 2 kmphs.

Retardation (β) = 3 kmphs.

The dead weight of the train (w) = 20 ton.

The track resistance (r) = 40 N/ton.

The overall efficiency (η) = 80%.

$$\begin{aligned} \text{The schedule time of run } T_s &= \frac{3,600 \times D}{V_s} \\ &= \frac{3,600 \times 3}{40} = 270 \text{ s.} \end{aligned}$$

$$\begin{aligned} \text{The actual time of run, } T &= 270 - 30 \\ &= 240 \text{ s.} \end{aligned}$$

$$\text{(i) The maximum speed, } V_m = \frac{T}{2X} - \sqrt{\frac{T^2}{4X^2} - \frac{3,600D}{X}},$$

where:

$$\begin{aligned} X &= \frac{1}{2\alpha} + \frac{1}{2\beta} \\ &= \frac{1}{2 \times 2} + \frac{1}{2 \times 3} = 0.416. \\ V_m &= \frac{240}{2 \times 0.416} - \sqrt{\frac{(240)^2}{4 \times (0.416)^2} - \frac{3,600 \times 3}{0.416}} \\ &= 288.46 - \sqrt{(83,210.059) - (25,961.538)} \\ &= 49.193 \text{ kmph.} \end{aligned}$$

$$\begin{aligned} \text{(ii) The acceleration time, } t_1 &= \frac{V_m}{\alpha} \\ &= \frac{49.193}{2} \\ &= 24.59 \text{ s.} \end{aligned}$$

$$\text{The duration of braking, } t_3 = \frac{V_m}{\beta} = \frac{49.193}{3} = 16.397 \text{ s.}$$

$$\begin{aligned} \text{The free-running time } t_2 &= T - (t_1 + t_3) \\ &= 240 - (24.59 + 16.397) \\ &= 199.012 \text{ s.} \end{aligned}$$

The tractive effort during acceleration:

$$F_t = 277.8W_e \times \alpha + Wr$$

$$= 277.8 \times 1.1 \times 20 \times 2 + 20 \times 40$$

$$= 13,023.2 \text{ N.}$$

$$\begin{aligned} \text{The maximum power output} &= \frac{F_t V_m}{3,600} \\ &= \frac{13,023.2 \times 49.193}{3,600}. \end{aligned}$$

The maximum power output = 177.958 kW.

(iii) The distance travelled during braking:

$$\begin{aligned} &= \frac{1}{2} \frac{V_m \times t_3}{3,600} \\ &= \frac{1}{2} \times \frac{49.193 \times 16.397}{3,600} \\ &= 0.112 \text{ km.} \end{aligned}$$

The distance travelled with power is on:

$$D_1 = 3 - 0.112$$

$$= 2.88 \text{ km.}$$

The specific energy output:

$$\begin{aligned}
&= \frac{0.01072V_m^2}{D} \times \frac{W_e}{W} + 0.2778r \frac{D_1}{D} \\
&= \left[\frac{0.01072 \times (49.193)^2}{3} \times 1.1 \right] + \left[0.2778 \times 40 \times \frac{2.88}{3} \right] \\
&= 9.512 + 10.667 \\
&= 20.179 \text{ W-hr/ton-km.}
\end{aligned}$$

$$\begin{aligned}
\text{The specific energy consumption} &= \frac{20.179}{\text{efficiency}} = \frac{20.179}{0.8} \\
&= 25.244 \text{ W-hr/ton-km.}
\end{aligned}$$

CALCULATION OF ENERGY RETURNED TO THE SUPPLY DURING REGENERATIVE BRAKING

When the train is accelerating, it acquires kinetic energy corresponding to that speed. During the coasting period, some of the kinetic energy is wasted, to propel the train against the friction and windage resistance.

While the train is moving on the down gradients or level track, the KE acquired by the rotating parts is converted into the electrical energy, which is fed back to the supply system. The amount of energy fed back to the system is depending on the following factors.

1. The initial and final speeds during the regenerative braking.
2. The train resistance and the gradient of the track.
3. The efficiency of the system.

Consider the initial and final speeds of the train during regenerative braking are V_1 and V_2 in KMPH, and the effective weight of the train is W_e tons.

$$\begin{aligned}
\text{Thus, the mass of the train, } m &= \frac{W_e}{g} \text{ tons/(m/s}^2\text{)} \\
&= \frac{1000W_e}{9.81} \text{ kg/(m/s}^2\text{)}.
\end{aligned}$$

$$\begin{aligned}\text{The speed of the train} &= V_1 \text{ kmph} \\ &= \frac{V_1 \times 1,000}{3,600} \text{ m/s.}\end{aligned}$$

The kinetic energy stored by the train at a speed of V_1 kmph:

$$\begin{aligned}&= \frac{1}{2} \times mv^2 \text{ J} \\ &= \frac{1}{2} \times \frac{1,000W_e}{9.81} \times \left[\frac{v_1 \times 1,000}{3,600} \right]^2 \frac{\text{kg}}{\text{m/s}^2} \times \frac{\text{m}}{\text{s}} \\ &= \frac{1}{2} \times \frac{1,000W_e}{9.81} \times \left[\frac{v_1 \times 1,000}{3,600} \right]^2 \times 9.81 \text{ N-m (or) } W\text{-sec} \\ &\hspace{15em} [1 \text{ kg-m} = 9.81 \text{ N-m}] \\ &= \frac{1}{2} \times \frac{1,000W_e}{9.81} \times \left[\frac{v_1 \times 1,000}{3,600} \right]^2 \times 9.81 \times \frac{1}{3,600} \text{ W-h} \\ &\hspace{15em} [1 \text{ W-Sec} = 1/3,600 \text{ W-h}] \\ &= 0.01072V_1^2W_e \text{ W-h} \\ &= 0.01072V_1^2 \left(\frac{W_e}{w} \right) \text{ W-h/ton.}\end{aligned}$$

Thus, the kinetic energy at speed V_2 kmph:

$$= 0.01072V_2^2 \left(\frac{W_e}{w} \right) \text{ W-h/ton.}$$

Therefore, the energy available during the regeneration:

$$= 0.01072 \left(\frac{W_e}{w} \right) \times (V_2^2 - V_1^2) \text{ W-h/ton.}$$

If D is the distance in km covered during the regenerative braking, then the energy fed back to the supply during the braking while the train is moving on down gradient:

$$\begin{aligned}
 &= WD \times \frac{G}{100} \text{ ton-km} \\
 &= (1,000 \times w) \times (1,000 \times D) \times \frac{G}{100} \\
 &= WDG \times 10^4 \text{ kg-m (or) N-sec}^2 \\
 &= 9.81 \times WDG \times 10^4 \text{ N-m (or) W-sec} \\
 &= \frac{9.81 \times WDG \times 10^4}{3,600} \text{ W-h} \\
 &= 27.25 WDG \text{ W-h} \\
 &= 27.25 DG \text{ W-h/ton.}
 \end{aligned}$$

If r is the train resistance in N/ton, then the energy lost to overcome the resistance to the motion and friction, windage losses:

$$\begin{aligned}
 &= WrD \text{ N-km} \\
 &= WrD \times 1,000 \text{ N-m (or) w-sec} \\
 &= \frac{WrD \times 1,000}{3,600} \text{ W-h} \\
 &= 0.2778 WrD \text{ W-h (or) } 0.2778 rD \frac{\text{W-h}}{\text{ton}}.
 \end{aligned}$$

Hence, the total energy available during regeneration:

$$= \left[0.01072 \left(\frac{W_c}{W} \right) (V_1^2 - V_2^2) + 27.25 DG - 0.2778 rD \right] \text{ W-h/ton.}$$

The energy returned to the supply system:

$$= \left[0.01072 \left(\frac{W_c}{W} \right) (V_1^2 - V_2^2) + 27.25 DG - 0.2778rD \right] \times \eta W \text{-h/ton,}$$

where η is the efficiency of the system.

Advantages of regenerative breaking

1. In regenerative breaking, a part of the energy stored by the rotating parts is converted into the electrical energy and is fed back to the supply. This will lead to the minimum consumption of energy, thereby saving the operating cost.
2. High breaking retardation can be obtained during regenerative breaking.
3. Time taken to bring the vehicle to rest is less compared to the other breakings; so that, the running time of the vehicle is considerably reduced.
4. The wear on the brake shoes and tyre is reduced, which increases the life of brake shoe and tyre.

Disadvantages

In addition to the above advantages, this method suffers from the following disadvantages.

1. In addition to the regenerative breaking, to bring the vehicle to standstill, mechanical breaking is to be employed.
2. In case of DC traction, additional equipment is to be employed for regenerative breaking, which increases the cost and sometimes, substation are equipped with mercury arc rectifiers to convert AC to DC supply.
3. The electrical energy returned to the supply will cause the operation of substations complicated.

Example 10.26: A 450-ton train travels down gradient of 1 in 75 for 110 s during which its speed is reduced from 70 to 55 kmph. By the regenerative braking, determine the energy returned to the lines if the reactive resistance is 4.5 kg/ton and the allowance for the rotational inertia is 7% and the overall efficiency of the motor is 80%.

Solution:

$$\begin{aligned}\text{Accelerating weight } W_a &= 1.075 \times 450 \\ &= 483.75 \text{ ton.}\end{aligned}$$

$$\begin{aligned}\text{Track resistance } r &= 9.81 \times 4.5 \\ &= 44.145 \text{ N-m/ton} \\ &= 9,904.782 \text{ W-hr} \\ &= 9.904 \text{ kW-hr.}\end{aligned}$$

Factive effort required during retardation:

$$\begin{aligned}&= Wr - 98.1 \text{ WG} \\ &= 450 \times 44.45 - 98.1 \times 450 \times 4/3 \\ &= 19,865.25 - 58,860 \\ &= -38,994.75 \text{ N.}\end{aligned}$$

The distance travelled during the retardation period:

$$\begin{aligned}&= \frac{V_1 + V_2}{2} \times \frac{1,000}{3,600} \times T \\ &= \frac{70 + 55}{2} \times \frac{1,000}{3,600} \times 110 \\ &= 1,909.73 \text{ m.}\end{aligned}$$

As the train is moving in downward gradient, so that the tractive effort will provide additional energy to the system. The energy available when the train moves over a gradient is given as:

$$= \frac{38,994.75 \times 1,909.73}{1,000 \times 3,600}$$

$$\begin{aligned} \text{Gradient } G &= \frac{1}{75} \times 100 \\ &= \frac{4}{3} \times 100. \end{aligned}$$

The period of regeneration = 110 s.

Overall efficiency (η) = 80%.

The kinetic energy of the train at a speed of 70 kmph is:

$$\begin{aligned} &= 0.01092 V_1^2 W_a \\ &= 0.01092 \times (70)^2 \times (483.75) \\ &= 25,884.495 \text{ W-hr.} \end{aligned}$$

The kinetic energy of the train at the speed of 55 kmph is:

$$\begin{aligned} &= 0.01092 V_2^2 W_a \\ &= 0.01092 \times (55)^2 \times (483.75) \\ &= 15,979.713 \text{ W-hr.} \end{aligned}$$

The energy available due to the retardation by the regenerative braking:

$$\begin{aligned} &= 25,884.495 - 15,979.713 \\ &= 20.68 \text{ kW-hr.} \end{aligned}$$

The energy returned to the supply system:

$$\begin{aligned} &= 0.8 \times \text{total energy available} \\ &= 0.8 \times (20.68 + 9.904) \\ &= 24.467 \text{ kW-hr.} \end{aligned}$$